

SPRAY TECH

(ORANGE CATALOG)
Electronic Copy



MANUFACTURING, INCORPORATED

TERMS AND CONDITIONS OF SALE

PRICING

List prices can be found in the current version of the annually published Spray Tech Price List.

MINIMUM ORDER

Orders under \$10 will be charged an additional \$2.50 handling fee.

TERMS OF SALE

30 days net to firms with established credit. Orders received prior to establishment of credit will be subject to COD or delay of shipment until credit has been cleared by our credit department. A finance charge will be made on all invoices not paid within terms of sale and will be computed by a periodic rate of 1.5% per month, which is an annual percentage rate of 18%. The minimum finance charge is \$0.50 per month. No further sales will be made to overdue accounts until the account is paid in full. Future terms will be COD.

REFERRAL SALES

A maximum discount of 10% is allowed on referral sales. Referrals are orders picked up at Spray Tech by a dealer's customer, without a purchase order specifying part numbers and quantities.

RETURNS FOR CREDIT

Merchandise may be returned for credit only upon authorization and receipt of a RMA number. Returns will be subject to a 20% restocking fee upon authorized return. Special order items are binding with placement of the order.

SHIPMENTS

All shipments are FOB our location and will be made by common carrier, UPS, Fed-Ex Ground, Parcel Post or our truck on special arrangements. Charges will be prepaid and insured and subsequently invoiced to the customer at tariff cost plus \$1 per order. Ship-to addresses will be charged an additional \$1. Spray Tech is not responsible for delays caused by accident, strikes, fires, and other causes beyond our control.

Spray Tech recognizes the desirability of filling orders promptly and agrees that it will at all times use its best efforts to make shipments promptly, but Spray Tech shall not be liable to Dealer or any other person for the failure to fill orders or to make shipments on time.

SPRAY TECH shall not be liable for damage to or loss of any material shipped to Dealer or its customer when such damage or loss occurs after SPRAY TECH has delivered the material to a carrier. Dealer shall assert all claims for damages or losses in transit directly against the carrier. IN NO EVENT SHALL SPRAY TECH BE LIABLE FOR INCIDENTAL OR CONSEQUENTIAL DAMAGES ARISING FROM SHORTAGES OR DEFECTIVE MATERIAL.

LIMITED WARRANTY

SPRAY TECH warrants the products manufactured by it, including all equipment or accessories supplied, to be free from defects in material or workmanship under proper and normal use and service. Manufacturer's obligation under this warranty is limited to repair or replacement at its factory of any defective items which shall within ninety(90) days of delivery to the original retail purchaser or first user, be returned with transportation charges prepaid. This warranty shall not apply to any product which has been subject to misuse, negligence, or accident. Parts furnished to Spray Tech by other manufacturers for resale or assembly by Spray Tech are warranted only to the extent of the original manufacturer's warranty. MANUFACTURER'S WARRANTIES SHALL BE APPLICABLE ON THOSE ITEMS WHICH THOSE MANUFACTURERS SUPPLY.

Any implied warranties, including any implied warranty of merchantability or fitness for a particular purpose, are limited in duration to the time period of the express warranty set forth herein. Some states do not allow limitations on how long an implied warranty lasts, or the exclusion or limitations of incidental or consequential damages, so the above limitation or exclusion may not apply to you. This warranty gives you specific legal rights and you may have other rights which vary from state to state.

SPRAY TECH

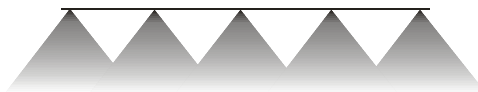

MANUFACTURING, INCORPORATED

TABLE OF CONTENTS

Spray Tips	pg 3
Boom Components	pg 36
Strainers	pg 54
Valves	pg 74
Pipe Fittings	pg 130
Hose Clamps	pg 136
Manifold Fittings	pg 138
Quick Connectors	pg 141
Gauges	pg 147
Spray Guns	pg 151
Spray Monitors	pg 154
Hose	pg 160
Guidance	pg 165
Rate Controls	pg 172
Ace Pumps	pg 178
Hypro Pumps	pg 190
Delavan Pumps	pg 236
Banjo Pumps	pg 259
12 Volt / ATV Pumps	pg 289
Tanks	pg 311
Sprayers	pg 317
Rope Wicks	pg 318
New Products / Miscellaneous	pg 319
Calibration / Reference	pg 329

Phone: 800.292.4066 573.379.5491

Fax: 800.628.9616 573.379.3482













Mailing address:

PO Box 380
Portageville, MO. 63873









Physical Delivery:

1579 US Hwy 61
Portageville, MO. 63873



SPRAY TIPS AND NOZZLES

BROADCAST NOZZLES		SIZE	ORIFICE INSERT/ TIP BODY MATERIAL <small>* Additional Materials Available, Call Spray Tech for Details</small>	PART NO. <small>(angle is 80 or 110)</small>
	XR TeeJet[®] EXTENDED RANGE TIPS (TAPERED FLAT FAN SPRAY) VisiFlo[®] COLOR-CODED	ALL SIZES	STAINLESS STEEL	SPXR(angle)(size)SS
			STAINLESS STEEL/CELCON	SPXR(angle)(size)VS
			POLYMER (110° only)	SPXR110(size)VP
CERAMIC	SPXR(angle)(size)VK			
	XRC TeeJet[®] EXTENDED RANGE TIPS (TAPERED FLAT FAN SPRAY) VisiFlo[®] COLOR-CODED		STAINLESS STEEL	SPXRC(angle)(size)VS
			CERAMIC	SPXRC(angle)(size)VK
			*	
	Turbo TwinJet[®] SPRAY TIPS (TWIN TAPERED FLAT FAN SPRAY) VisiFlo[®] COLOR-CODED		POLYMER (110° only)	SPTTT110(size)
	Turbo TeeJet[®] SPRAY TIPS (TAPERED FLAT FAN SPRAY) VisiFlo[®] COLOR-CODED			SPTBJ110(size)
	Turbo TeeJet[®] Duo DOUBLE OUTLET QJ ADAPTER WITH 2 TURBO TEEJET [®] TIPS (TWIN TAPERED FLAT FAN SPRAY) VisiFlo[®] COLOR-CODED	POLYMER	SPQJ90-2X(size)	
	Turbo TeeJet[®] Induction AIR INDUCTION SPRAY TIPS (TAPERED FLAT FAN SPRAY) VisiFlo[®] COLOR-CODED		SPTTI110(size)	
	AI TeeJet[®] AIR INDUCTION SPRAY TIPS (TAPERED FLAT FAN SPRAY) VisiFlo[®] COLOR-CODED	STAINLESS STEEL/CELCON	SPA110(size)	
	AIC TeeJet[®] AIR INDUCTION SPRAY TIPS (TAPERED FLAT FAN SPRAY) VisiFlo[®] COLOR-CODED		SPAIC110(size)	
		*		
	DG TeeJet[®] DRIFT GUARD TIPS (TAPERED FLAT FAN SPRAY) VisiFlo[®] COLOR-CODED	STAINLESS STEEL/CELCON	SPDG(angle)(size)VS	
		*		
	TeeJet[®] SPRAY TIPS (TAPERED FLAT FAN SPRAY)	ALL SIZES	BRASS	SP(angle)(size)
		-01 AND LARGER	STAINLESS STEEL	SP(angle)(size)SS
	TeeJet[®] SPRAY TIPS (TAPERED FLAT FAN SPRAY) VisiFlo[®] COLOR-CODED	-01 AND LARGER	STAINLESS STEEL/CELCON	SP(angle)(size)VS
		ALL SIZES	POLYMER	SP(angle)(size)VP
			CERAMIC	SP(angle)(size)VK
	TwinJet[®] SPRAY TIPS (TWIN TAPERED FLAT FAN SPRAY) VisiFlo[®] COLOR-CODED	ALL SIZES	STAINLESS STEEL/CELCON	SPTJ80(size)VS

SPRAY TIPS AND NOZZLES

BROADCAST NOZZLES		SIZE	ORIFICE INSERT/ TIP BODY MATERIAL/STYLE <small>* additional materials may be available, call Spray Tech for details</small>	PART NO.
	DG TwinJet DRIFT GUARD TWINJET SPRAY TIPS (TWIN TAPERED FLAT FAN SPRAY) VisiFlo COLOR-CODED	ALL SIZES	STAINLESS STEEL/CELCON	SPDGTJ110(size)
	Turbo FloodJet SPRAY TIPS (WIDE ANGLE FLAT FAN SPRAY) VisiFlo COLOR-CODED		*	SPTFVS(size)
	FloodJet SPRAY TIPS (WIDE ANGLE FLAT FAN SPRAY) VisiFlo COLOR-CODED		BRASS	SPTK(size)
	DELAVAN 'D' Flood Tips		ALL SIZES	ALL POLY
	FloodJet NOZZLES (WIDE ANGLE TAPERED FLAT FAN SPRAY)	SEE EXAMPLE	BRASS	(1/8") SP18K-(size) (1/4") SP14K-(size) (3/8") SP38K-(size) (1/2") SP12K-(size) (3/4") SP34K-(90 - 210) (1") SP1K-300 (1") SP1K-450
			STAINLESS STEEL	(1/8") SP18K(size)SS (1/4") SP14K(size)SS (3/8") SP38K(size)SS (1/2") SP12K(size)SS (3/4") SP34K(90 - 210)SS (1") SP1K300SS (1") SP1K450SS
	GREENLEAF AIR INDUCTION TURBO DROP (ADDITIONAL PHOTOS ON PAGE 8)	ALL SIZES	TURBODROP POLY POLY VENTURI ONLY	GTTDXL(size) GTTDXLV-(size)
	GREENLEAF AIR MIX		T.D. POLY w/CERAMIC CORE POLY/CERAMIC VENTURI ONLY	GTTDCXL(size) GTTDVC(size)
			GASKET HARDI APAPTER GASKET DIFFUSER	GTG125 GTGH170 GTDIF4
HYPRO TOTAL RANGE		POLYACETAL (general spraying)	GTAM110(size)	
		ACID-RESISTANT POLY ACID-RESISTANT POLY CAP <small>(suitable for acidic cotton applications only)</small>	GTAMCQ(size) GTC06	
HYPRO TOTAL RANGE		FASTCAP 80° 110°	FC-TR80-(size) FC-TR110-(size)	
		STD TIP 80° 110°	TR80-(size) TR110-(size)	











SPRAY TIPS AND NOZZLES

BROADCAST NOZZLES		SIZE	ORIFICE INSERT/ TIP BODY MATERIAL/STYLE	PART NO.
HYPRO LO-DRIFT		ALL SIZES	FASTCAP 80° 110°	LD(size)F80 LD(size)F110
			STD TIP 80° 110°	FC-LD(size)F80 FC-LD(size)F110
HYPRO ULTRA LO- DRIFT			FASTCAP 120°	FC-ULD120-(size)
			STD TIP 120°	ULD120-(size)
HYPRO TWIN CAP		(LESS TIPS)	STD TWIN CAP	HY152607TC
			ACID-RESISTANT TWIN CAP (suitable for certain cotton applications)	HY15Q2530TC

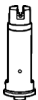





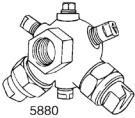

The complete **HYPRO** line of spray tips is available. Call Spray Tech for price and availability.

WILGER Combo-Jet	<p>SR, MR & DR Models To clean exit orifice, pull strainer and pre-orifice up and out. Push down to snap back in. To clean pre-orifice, push strainer sideways to snap out and push down to snap in.</p>  <p>MR110-0</p>	AVAILABLE MODELS:	SR, MR, DR, ER	Call Spray Tech for price and availability.



SPRAY TIPS AND NOZZLES

BANDING & DIRECTED NOZZLES		SIZE	ORIFICE INSERT/ TIP BODY MATERIAL	PART NO.	
	AI TeeJet[™] AIR INDUCTION EVEN SPRAY TIPS (EVEN FLAT FAN SPRAY) VisiFlo[™] COLOR-CODED	ALL SIZES	STAINLESS STEEL/CELCON	SPA1950(size)	
	DG TeeJet[™] EVEN SPRAY TIPS (EVEN FLAT FAN SPRAY) VisiFlo[™] COLOR-CODED		STAINLESS STEEL/CELCON WITH POLYMER PRE-ORIFICE	SPDG95(size)E	
	TeeJet[™] SPRAY TIPS (EVEN FLAT FAN SPRAY) VisiFlo[™] COLOR-CODED	-01 AND LARGER	BRASS	SP80(size)E	
			STAINLESS STEEL	SP80(size)ESS	
			HARDENED SS	SP80(size)EHSS	
			STAINLESS STEEL/CELCON	SP80(size)EVS	
	TwinJet[™] SPRAY TIPS (TWIN EVEN FLAT FAN SPRAY) VisiFlo[™] COLOR-CODED	ALL SIZES	STAINLESS STEEL/CELCON	SPTJ80(size)EVS	
	TeeJet[™] SPRAY TIPS (DOUBLE OUTLET FLAT FAN SPRAY)		BRASS	SP150(size)	
			STAINLESS STEEL	SP150(size)SS	
	AIUB TeeJet[™] AIR INDUCTION (UNDERLEAF BANDING SPRAY TIPS) VisiFlo[™] COLOR-CODED		STAINLESS STEEL/CELCON	SPAIUB95(size)	
	TeeJet[™] OC SPRAY TIPS (OFF CENTER FLAT FAN SPRAY)		-01 THRU -08, -12, -16	BRASS	SPOC(size)
			STAINLESS STEEL	SPOC(size)SS	
	TG FullJet[™] SPRAY TIPS (FULL CONE SPRAY)	1 AND LARGER	BRASS	SPTG(size)	
			STAINLESS STEEL	SPTG(size)SS	
	TX ConeJet[™] SPRAY TIPS (HOLLOW CONE SPRAY)	ALL SIZES	BRASS	SPTX(size)	
			STAINLESS STEEL	SPTX(size)SS	
			CERAMIC	SPTXA80(size) SPTXB80(size) SPTX(size)VK	
			STAINLESS STEEL/CELCON	SPTX(size)VS	
	TX, TXA, TXB ConeJet[™] (HOLLOW CONE SPRAY) VisiFlo[™] COLOR-CODED				
	TeeJet[™] ORIFICE DISCS	ALL SIZES	HARD. STAINLESS STEEL	SPD(size)	
			CERAMIC	SPD(size)CER	
	TeeJet[™] CORES	ALL SIZES	NYLON	SP(size)NY	
			BRASS	SP(size)	
			HARD. STAINLESS STEEL	SP(size)HSS	
			CERAMIC	SP(size)CER	
DELAVAN Raindrop (Command tip)		3, 5, 6	STAINLESS STEEL	DE50626-(size)	

SPRAY TIPS AND NOZZLES

SPRAY TIPS AND NOZZLES			
BOOMLESS NOZZLES <small>(other brands available)</small>	SIZE	ORIFICE INSERT/ TIP BODY MATERIAL	PART NO.
 <p>BoomJet® LARGE CAPACITY NOZZLES AND SWIVELS (BOOMLESS FLAT SPRAY)</p>	SEE EXAMPLES	BRASS	SP4629-(10 - 80) SP5880-(06 - 40)
		STAINLESS STEEL	SPOC(01 - 80)SS
 <p>TeeJet® OC SPRAY TIPS (LARGE CAPACITY OFF-CENTER FLAT SPRAY TIPS)</p>		ACETAL	SP14XP ^(size) R-V SP14XP ^(size) L-V
 <p>XP BoomJet® NOZZLE (BOOMLESS FLAT SPRAY)</p> <p>VisiFlo® COLOR-CODED</p>	1/4": 10, 20, 25	STAINLESS STEEL	SP14XP ^(size) R-S SP14XP ^(size) L-S
	1/2": 40, 80	ACETAL	SP12XP ^(size) R-V SP12XP ^(size) L-V
		STAINLESS STEEL	SP12XP ^(size) R-S SP12XP ^(size) L-S
	 <p>FieldJet® NOZZLES (BOOMLESS FLAT SPRAY)</p>	ALL SIZES	BRASS
STAINLESS STEEL			(1/4") SP14KLC ^(size) SS (3/4") SP34KLC ^(size) SS
 <p>TFW Turbo FloodJet® NOZZLES (EXTRA WIDE ANGLE TAPERED FLAT FAN SPRAY)</p> <p>VisiFlo® COLOR-CODED</p>	ALL SIZES	BRASS	SPTFW-(size)
FERTILIZER NOZZLES	SIZE	ORIFICE INSERT/ TIP BODY MATERIAL	PART NO.
 <p>StreamJet® FERTILIZER NOZZLE (SOLID STREAM NOZZLE)</p>	0002-0080	STAINLESS STEEL	SPH14U-00(size)
 <p>StreamJet® SJ-7 FERTILIZER NOZZLES (7 ORIFICES WITH QUICK TEEJET® CONNECTION)</p> <p>VisiFlo® COLOR-CODED</p>	ALL SIZES	CELCON	SPSJ7-(size)
 <p>StreamJet® SJ-3 FERTILIZER NOZZLES (3 SOLID STREAM ORIFICES)</p> <p>VisiFlo® COLOR-CODED</p>			SPSJ3-(size)
 <p>TeeJet® FLOW REGULATORS (Orifice Regulating Plates- sizes are in thousandths of an inch)</p> <p>CAP GASKET</p>	(10 - 250)	STAINLESS STEEL	SP4916-(size)
		EPDM	SPQ18999

SPRAY TIPS AND NOZZLES

FERTILIZER NOZZLES		SIZE	ORIFICE INSERT/ TIP BODY MATERIAL	PART NO.
	HYPRO FAST-CAP SIX-STREAM FERTILIZER TIP	015 - 06	POLY FAST CAP, CERAMIC INSERT	HYFCESI _(size)
	TIP ONLY		POLY, CERAMIC INSERT	HYESI _(size)
	HYPRO HI-FLOW WIDE ANGLE DRIFT REDUCING TIP 140° Spray Fan	08, 10, 15 (.8, 1, 1.5 gpm)	POLY	HYHF _(size)

ADDITIONAL INFORMATION ON GREENLEAF TURBODROP BROADCAST TIPS:



1. Noticable lack of driftable 'fines'; more product makes it to the target.



2. Results in an obvious reduction in drift.

GREENLEAF TECHNOLOGIES

Turbo TeeJet® Wide Angle Flat Spray Tips

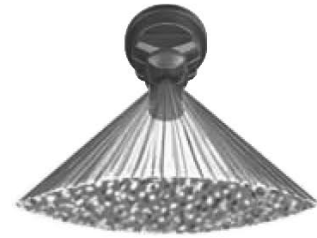

Features:

- Tapered edge wide angle flat spray pattern for uniform coverage in broadcast spraying.
- Large, rounded internal passage to minimize clogging.
- Excellent resistance to corrosive solutions.
- Superior wear characteristics.
- Larger droplets for less drift — 15–90 PSI (1–6 bar).
- Automatic spray alignment with Quick TeeJet® cap and gasket.
- Blockage-free passage means less clogging.
- Unique internal configuration means substantially longer wear life.

NOZZLE SIZE	PSI	DROPS PER MIN.	CAPACITY ONE NOZZLE IN GPM	CAPACITY ONE NOZZLE IN OZ./MIN.	GPA										GALLONS PER 1000 SQ. FT.			
					20°													
					4 MPH	5 MPH	6 MPH	8 MPH	10 MPH	12 MPH	15 MPH	20 MPH	2 MPH	3 MPH	4 MPH	5 MPH		
TT11001 (100)	15	C	0.061	7.8	4.5	3.6	3.0	2.3	1.8	1.5	1.2	0.91	0.21	0.14	0.10	0.08		
	20	M	0.071	9.1	5.3	4.2	3.5	2.6	2.1	1.8	1.4	1.1	0.24	0.16	0.12	0.10		
	30	M	0.087	11	6.5	5.2	4.3	3.2	2.6	2.2	1.7	1.3	0.30	0.20	0.15	0.12		
	40	M	0.10	13	7.4	5.9	5.0	3.7	3.0	2.5	2.0	1.5	0.34	0.23	0.17	0.14		
	50	F	0.11	14	8.2	6.5	5.4	4.1	3.3	2.7	2.2	1.6	0.37	0.25	0.19	0.15		
TT110015 (100)	15	C	0.092	12	6.8	5.5	4.6	3.4	2.7	2.3	1.8	1.4	0.31	0.21	0.16	0.13		
	20	C	0.11	14	8.2	6.5	5.4	4.1	3.3	2.7	2.2	1.6	0.37	0.25	0.19	0.15		
	30	M	0.13	17	9.7	7.7	6.4	4.8	3.9	3.2	2.6	1.9	0.44	0.29	0.22	0.18		
	40	M	0.15	19	11.1	8.9	7.4	5.6	4.5	3.7	3.0	2.2	0.51	0.34	0.26	0.20		
	50	M	0.17	22	12.6	10.1	8.4	6.3	5.0	4.2	3.4	2.5	0.58	0.39	0.29	0.23		
TT11002 (50)	15	C	0.12	15	8.9	7.1	5.9	4.5	3.6	3.0	2.4	1.8	0.41	0.27	0.20	0.16		
	20	C	0.14	18	10.4	8.3	6.9	5.2	4.2	3.5	2.8	2.1	0.48	0.32	0.24	0.19		
	30	M	0.17	22	12.6	10.1	8.4	6.3	5.0	4.2	3.4	2.5	0.58	0.39	0.29	0.23		
	40	M	0.20	26	14.9	11.9	9.9	7.4	5.9	5.0	4.0	3.0	0.68	0.45	0.34	0.27		
	50	M	0.22	28	16.3	13.1	10.9	8.2	6.5	5.4	4.4	3.3	0.75	0.50	0.37	0.30		
TT110025 (50)	15	VC	0.15	19	11.1	8.9	7.4	5.6	4.5	3.7	3.0	2.2	0.51	0.34	0.26	0.20		
	20	C	0.18	23	13.4	10.7	8.9	6.7	5.3	4.5	3.6	2.7	0.61	0.41	0.31	0.24		
	30	C	0.22	28	16.3	13.1	10.9	8.2	6.5	5.4	4.4	3.3	0.75	0.50	0.37	0.30		
	40	M	0.25	32	18.6	14.9	12.4	9.3	7.4	6.2	5.0	3.7	0.85	0.57	0.43	0.34		
	50	M	0.28	36	21	16.6	13.9	10.4	8.3	6.9	5.5	4.2	0.95	0.63	0.48	0.38		
TT11003 (50)	15	VC	0.18	23	13.4	10.7	8.9	6.7	5.3	4.5	3.6	2.7	0.61	0.41	0.31	0.24		
	20	VC	0.21	27	15.6	12.5	10.4	7.8	6.2	5.2	4.2	3.1	0.71	0.48	0.36	0.29		
	30	C	0.26	33	19.3	15.4	12.9	9.7	7.7	6.4	5.1	3.9	0.88	0.59	0.44	0.35		
	40	C	0.30	38	22	17.8	14.9	11.1	8.9	7.4	5.9	4.5	1.0	0.68	0.51	0.41		
	50	M	0.34	44	25	20	16.8	12.6	10.1	8.4	6.7	5.0	1.2	0.77	0.58	0.46		
TT11004 (50)	15	XC	0.24	31	17.8	14.3	11.9	8.9	7.1	5.9	4.8	3.6	0.82	0.54	0.41	0.33		
	20	VC	0.28	36	21	16.6	13.9	10.4	8.3	6.9	5.5	4.2	0.95	0.63	0.48	0.38		
	30	C	0.35	45	26	21	17.3	13.0	10.4	8.7	6.9	5.2	1.2	0.79	0.60	0.48		
	40	C	0.40	51	30	24	19.8	14.9	11.9	9.9	7.9	5.9	1.4	0.91	0.68	0.54		
	50	C	0.45	58	33	27	22	16.7	13.4	11.1	8.9	6.7	1.5	1.0	0.77	0.61		
TT11005 (50)	15	XC	0.31	40	23	18.4	15.3	11.5	9.2	7.7	6.1	4.6	1.1	0.70	0.53	0.42		
	20	VC	0.35	45	26	21	17.3	13.0	10.4	8.7	6.9	5.2	1.2	0.79	0.60	0.48		
	30	VC	0.43	55	32	26	21	16.0	12.8	10.6	8.5	6.4	1.5	0.97	0.73	0.58		
	40	C	0.50	64	37	30	25	18.6	14.9	12.4	9.9	7.4	1.7	1.1	0.85	0.68		
	50	C	0.56	72	42	33	28	21	16.6	13.9	11.1	8.3	1.9	1.3	0.95	0.76		
TT11006 (50)	15	XC	0.37	47	27	22	18.3	13.7	11.0	9.2	7.3	5.5	1.3	0.84	0.63	0.50		
	20	XC	0.42	54	31	25	21	15.6	12.5	10.4	8.3	6.2	1.4	0.95	0.71	0.57		
	30	VC	0.52	67	39	31	26	19.3	15.4	12.9	10.3	7.7	1.8	1.2	0.88	0.71		
	40	C	0.60	77	45	36	30	22	17.8	14.9	11.9	8.9	2.0	1.4	1.0	0.82		
	50	C	0.67	86	50	40	33	25	19.9	16.6	13.3	9.9	2.3	1.5	1.1	0.91		
TT11008 (50)	15	XC	0.49	63	36	29	24	18.2	14.6	12.1	9.7	7.3	1.7	1.1	0.83	0.67		
	20	XC	0.57	73	42	34	28	21	16.9	14.1	11.3	8.5	1.9	1.3	0.97	0.75		
	30	VC	0.69	88	51	41	34	26	20	17.1	13.7	10.2	2.3	1.6	1.2	0.94		
	40	VC	0.80	102	59	48	40	30	24	19.8	15.8	11.9	2.7	1.8	1.4	1.1		
	50	C	0.89	114	66	53	44	33	26	22	17.6	13.2	3.0	2.0	1.5	1.2		

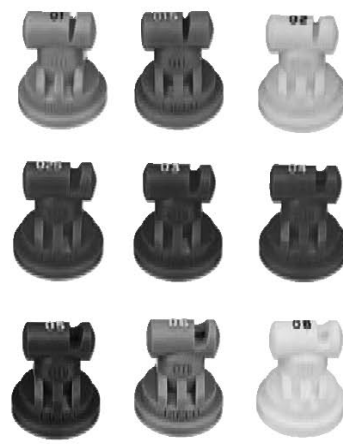

CONTACT PRODUCT	SYSTEMIC PRODUCT	DRIFT MANAGEMENT
VERY GOOD	VERY GOOD	VERY GOOD
GOOD*	EXCELLENT*	VERY GOOD*

*At pressures below 30 PSI (2.0 bar)

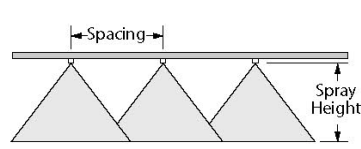

Optimum Spray Height

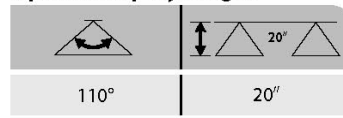

Note: Always double check your application rates. Tabulations are based on spraying water at 70°F (21°C).

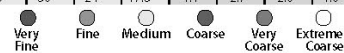

BROADCAST NOZZLES

TurboTwinJet® Twin Flat Spray Tips

Features:

- Dual outlet design produces two 110° flat fan spray patterns using the patented technology from the Turbo TeeJet® nozzle. The angle between each spray pattern is 60° forward and back.
- Best suited for broadcast spraying where superior leaf coverage and canopy penetration is important.
- Droplet size range is slightly larger than for the same capacity Turbo TeeJet nozzle providing drift-reducing properties with increased canopy coverage and penetration.
- Molded polymer for excellent chemical and wear resistance.
- Available in six VisiFlo® color-coded capacities with pressure ranges from 20–90 PSI (1.5–6 bar).
- Ideal for use with automatic sprayer controllers.
- Automatic alignment when used with Quick TeeJet® cap and gasket.

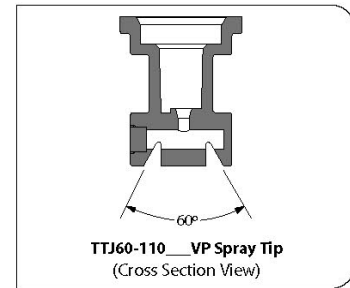

NOZZLE SIZE	DROPLET SIZE	CAPACITY ONE NOZZLE IN GPM	CAPACITY ONE NOZZLE IN OZ./MIN.	20°																
				GPA								GALLONS PER 1000 SQ. FT.								
				4 MPH	5 MPH	6 MPH	8 MPH	10 MPH	12 MPH	15 MPH	20 MPH	2 MPH	3 MPH	4 MPH	5 MPH					
TTJ60-11002 (100)	20	C	0.14	18	10.4	8.3	6.9	5.2	4.2	3.5	2.8	2.1	0.48	0.32	0.24	0.19	0.48	0.32	0.24	0.19
	30	C	0.17	22	12.6	10.1	8.4	6.3	5.0	4.2	3.4	2.5	0.58	0.39	0.29	0.23	0.58	0.39	0.29	0.23
	40	C	0.20	26	14.9	11.9	9.9	7.4	5.9	5.0	4.0	3.0	0.68	0.45	0.34	0.27	0.68	0.45	0.34	0.27
	50	M	0.22	28	16.3	13.1	10.9	8.2	6.5	5.4	4.4	3.3	0.75	0.50	0.37	0.30	0.75	0.50	0.37	0.30
	60	M	0.24	31	17.8	14.3	11.9	8.9	7.1	5.9	4.8	3.6	0.82	0.54	0.41	0.33	0.82	0.54	0.41	0.33
	70	M	0.26	33	19.3	15.4	12.9	9.7	7.7	6.4	5.1	3.9	0.88	0.59	0.44	0.35	0.88	0.59	0.44	0.35
TTJ60-110025 (100)	20	VC	0.18	23	13.4	10.7	8.9	6.7	5.3	4.5	3.6	2.7	0.61	0.41	0.31	0.24	0.61	0.41	0.31	0.24
	30	C	0.22	28	16.3	13.1	10.9	8.2	6.5	5.4	4.4	3.3	0.75	0.50	0.37	0.30	0.75	0.50	0.37	0.30
	40	C	0.25	32	18.6	14.9	12.4	9.3	7.4	6.2	5.0	3.7	0.85	0.57	0.43	0.34	0.85	0.57	0.43	0.34
	50	C	0.28	36	21	16.6	13.9	10.4	8.3	6.9	5.5	4.2	0.95	0.63	0.48	0.38	0.95	0.63	0.48	0.38
	60	C	0.31	40	23	18.4	15.3	11.5	9.2	7.7	6.1	4.6	1.1	0.70	0.53	0.42	1.1	0.70	0.53	0.42
	70	M	0.33	42	25	19.6	16.3	12.3	9.8	8.2	6.5	4.9	1.1	0.75	0.56	0.45	1.1	0.75	0.56	0.45
TTJ60-11003 (100)	20	VC	0.21	27	15.6	12.5	10.4	7.8	6.2	5.2	4.2	3.1	0.71	0.48	0.36	0.29	0.71	0.48	0.36	0.29
	30	C	0.26	33	19.3	15.4	12.9	9.7	7.7	6.4	5.1	3.9	0.88	0.59	0.44	0.35	0.88	0.59	0.44	0.35
	40	C	0.30	38	22	17.8	14.9	11.1	8.9	7.4	5.9	4.5	1.0	0.68	0.51	0.41	1.0	0.68	0.51	0.41
	50	C	0.34	44	25	20	16.8	12.6	10.1	8.4	6.7	5.0	1.2	0.77	0.58	0.46	1.2	0.77	0.58	0.46
	60	C	0.37	47	27	22	18.3	13.7	11.0	9.2	7.3	5.5	1.3	0.84	0.63	0.50	1.3	0.84	0.63	0.50
	70	C	0.40	51	30	24	19.8	14.9	11.9	9.9	7.9	5.9	1.4	0.91	0.68	0.54	1.4	0.91	0.68	0.54
TTJ60-11004 (50)	20	VC	0.28	36	21	16.6	13.9	10.4	8.3	6.9	5.5	4.2	0.95	0.63	0.48	0.38	0.95	0.63	0.48	0.38
	30	C	0.35	45	26	21	17.3	13.0	10.4	8.7	6.9	5.2	1.2	0.79	0.60	0.48	1.2	0.79	0.60	0.48
	40	C	0.40	51	30	24	19.8	14.9	11.9	9.9	7.9	5.9	1.4	0.91	0.68	0.54	1.4	0.91	0.68	0.54
	50	C	0.45	58	33	27	22	16.7	13.4	11.1	8.9	6.7	1.5	1.0	0.77	0.61	1.5	1.0	0.77	0.61
	60	C	0.49	63	36	29	24	18.2	14.6	12.1	9.7	7.3	1.7	1.1	0.83	0.67	1.7	1.1	0.83	0.67
	70	C	0.53	68	39	31	26	19.7	15.7	13.1	10.5	7.9	1.8	1.2	0.90	0.72	1.8	1.2	0.90	0.72
TTJ60-11005 (50)	20	VC	0.35	45	26	21	17.3	13.0	10.4	8.7	6.9	5.2	1.2	0.79	0.60	0.48	1.2	0.79	0.60	0.48
	30	C	0.43	55	32	26	21	16.0	12.8	10.6	8.5	6.4	1.5	0.97	0.73	0.58	1.5	0.97	0.73	0.58
	40	C	0.50	64	37	30	25	18.6	14.9	12.4	9.9	7.4	1.7	1.1	0.85	0.68	1.7	1.1	0.85	0.68
	50	C	0.56	72	42	33	28	21	16.6	13.9	11.1	8.3	1.9	1.3	0.95	0.76	1.9	1.3	0.95	0.76
	60	C	0.61	78	45	36	30	23	18.1	15.1	12.1	9.1	2.1	1.4	1.0	0.83	2.1	1.4	1.0	0.83
	70	C	0.66	84	49	39	33	25	19.6	16.3	13.1	9.8	2.2	1.5	1.1	0.90	2.2	1.5	1.1	0.90
TTJ60-11006 (50)	20	VC	0.42	54	31	25	21	15.6	12.5	10.4	8.3	6.2	1.4	0.95	0.71	0.57	1.4	0.95	0.71	0.57
	30	C	0.52	67	39	31	26	19.3	15.4	12.9	10.3	7.7	1.8	1.2	0.88	0.71	1.8	1.2	0.88	0.71
	40	C	0.60	77	45	36	30	22	17.8	14.9	11.9	8.9	2.0	1.4	1.0	0.82	2.0	1.4	1.0	0.82
	50	C	0.67	86	50	40	33	25	19.9	16.6	13.3	9.9	2.3	1.5	1.1	0.91	2.3	1.5	1.1	0.91
	60	C	0.73	93	54	43	36	27	22	18.1	14.5	10.8	2.5	1.7	1.2	0.99	2.5	1.7	1.2	0.99
	70	C	0.79	101	59	47	39	29	23	19.6	15.6	11.7	2.7	1.8	1.3	1.1	2.7	1.8	1.3	1.1

Note: Always double check your application rates. Tabulations are based on spraying water at 70°F (21°C).



CONTACT PRODUCT	SYSTEMIC PRODUCT	DRIFT MANAGEMENT
EXCELLENT	EXCELLENT	VERY GOOD
VERY GOOD*	EXCELLENT*	EXCELLENT*

*At pressures below 30 PSI (2.0 bar)

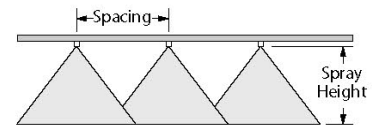

Optimum Spray Height

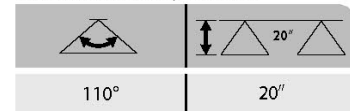

Turbo TeeJet® Induction Flat Spray Tips

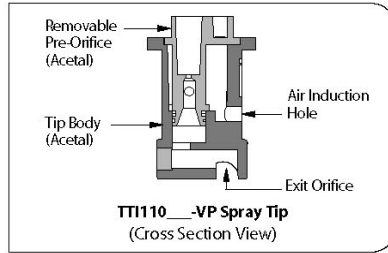

Note: Due to pre-orifice design, this tip is not compatible with the 4193A check valve tip strainer.



Features:

- 110° wide angle, air induction, tapered flat spray tip pattern based on the patented outlet orifice design of the original Turbo TeeJet® nozzle.
- Patented orifice design provides large, round passages to minimize plugging.
- Depending on the chemical, produces large air-filled drops through a Venturi air aspirator resulting in less drift.
- All polymer construction for excellent chemical and wear resistance.
- Compact size to prevent tip damage.
- Removable pre-orifice.
- Ideal for use with automatic sprayer controllers.

- Wide operating pressure range: 15–100 PSI (1–7 bar).
- Automatic alignment when used with Quick TeeJet® cap and gasket.



PSI	DROPSIZE	CAPACITY ONE NOZZLE IN OZ./MIN.	20°												GALLONS PER 1000 SQ. FT.				
			GPA																
			4 MPH	5 MPH	6 MPH	8 MPH	10 MPH	12 MPH	15 MPH	20 MPH	2 MPH	3 MPH	4 MPH	5 MPH					
TTI110015 (100)	15 XC	0.092	12	6.8	5.5	4.6	3.4	2.7	2.3	1.8	1.4	0.31	0.21	0.16	0.13				
	20 XC	0.11	14	8.2	6.5	5.4	4.1	3.3	2.7	2.2	1.6	0.37	0.25	0.19	0.15				
	30 XC	0.13	17	9.7	7.7	6.4	4.8	3.9	3.2	2.6	1.9	0.44	0.29	0.22	0.18				
	40 XC	0.15	19	11.1	8.9	7.4	5.6	4.5	3.7	3.0	2.2	0.51	0.34	0.26	0.20				
	50 XC	0.17	22	12.6	10.1	8.4	6.3	5.0	4.2	3.4	2.5	0.58	0.39	0.29	0.23				
TTI11002 (50)	15 XC	0.12	15	8.9	7.1	5.9	4.5	3.6	3.0	2.4	1.8	0.41	0.27	0.20	0.16				
	20 XC	0.14	18	10.4	8.3	6.9	5.2	4.2	3.5	2.8	2.1	0.48	0.32	0.24	0.19				
	30 XC	0.17	22	12.6	10.1	8.4	6.3	5.0	4.2	3.4	2.5	0.58	0.39	0.29	0.23				
	40 XC	0.20	26	14.9	11.9	9.9	7.4	5.9	5.0	4.0	3.0	0.68	0.45	0.34	0.27				
	50 XC	0.22	28	16.3	13.1	10.9	8.2	6.5	5.4	4.4	3.3	0.75	0.50	0.37	0.30				
TTI110025 (50)	15 XC	0.15	19	11.1	8.9	7.4	5.6	4.5	3.7	3.0	2.2	0.51	0.34	0.26	0.20				
	20 XC	0.18	23	13.4	10.7	8.9	6.7	5.3	4.5	3.6	2.7	0.61	0.41	0.31	0.24				
	30 XC	0.22	28	16.3	13.1	10.9	8.2	6.5	5.4	4.4	3.3	0.75	0.50	0.37	0.30				
	40 XC	0.25	32	18.6	14.9	12.4	9.3	7.4	6.2	5.0	3.7	0.85	0.57	0.43	0.34				
	50 XC	0.28	36	21	16.6	13.9	10.4	8.3	6.9	5.5	4.2	0.95	0.63	0.48	0.38				
TTI11003 (50)	15 XC	0.18	23	13.4	10.7	8.9	6.7	5.3	4.5	3.6	2.7	0.61	0.41	0.31	0.24				
	20 XC	0.21	27	15.6	12.5	10.4	7.8	6.2	5.2	4.2	3.1	0.71	0.48	0.36	0.29				
	30 XC	0.26	33	19.3	15.4	12.9	9.7	7.7	6.4	5.1	3.9	0.88	0.59	0.44	0.35				
	40 XC	0.30	38	22	17.8	14.9	11.1	8.9	7.4	5.9	4.5	1.0	0.68	0.51	0.41				
	50 XC	0.34	44	25	20	16.8	12.6	10.1	8.4	6.7	5.0	1.2	0.77	0.58	0.46				
TTI11004 (50)	15 XC	0.24	31	17.8	14.3	11.9	8.9	7.1	5.9	4.8	3.6	0.82	0.54	0.41	0.33				
	20 XC	0.27	35	20	16.6	13.9	10.4	8.3	6.9	5.5	4.2	0.95	0.63	0.48	0.38				
	30 XC	0.35	45	26	21	17.3	13.0	10.4	8.7	6.9	5.2	1.2	0.79	0.60	0.48				
	40 XC	0.40	51	30	24	19.8	14.9	11.9	9.9	7.9	5.9	1.4	0.91	0.68	0.54				
	50 XC	0.45	58	33	27	22	16.7	13.4	11.1	8.9	6.7	1.5	1.0	0.77	0.61				
TTI11005 (50)	15 XC	0.31	40	24	19.8	14.9	11.9	9.9	7.9	5.9	4.4	1.1	0.70	0.53	0.42				
	20 XC	0.36	47	27	22	18.3	13.7	11.0	9.2	7.3	5.5	1.3	0.84	0.63	0.50				
	30 XC	0.43	55	32	26	21	16.0	12.8	10.6	8.5	6.4	1.5	0.97	0.73	0.58				
	40 XC	0.50	64	37	30	25	18.6	14.9	12.4	9.9	7.4	1.7	1.1	0.85	0.68				
	50 XC	0.56	72	42	33	28	21	16.6	13.9	11.1	8.3	1.9	1.3	0.95	0.76				
TTI11006 (50)	15 XC	0.37	47	27	22	18.3	13.7	11.0	9.2	7.3	5.5	1.3	0.84	0.63	0.50				
	20 XC	0.42	54	31	25	21	15.6	12.5	10.4	8.3	6.2	1.4	0.95	0.71	0.57				
	30 XC	0.52	67	39	31	26	19.3	15.4	12.9	10.3	7.7	1.8	1.2	0.88	0.71				
	40 XC	0.60	77	45	36	30	22	17.8	14.9	11.9	8.9	2.0	1.4	1.0	0.82				
	50 XC	0.67	86	50	40	33	25	19.9	16.6	13.3	9.9	2.3	1.5	1.1	0.91				

Note: Always double check your application rates. Tabulations are based on spraying water at 70°F (21°C).

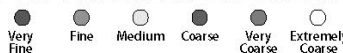

CONTACT PRODUCT	SYSTEMIC PRODUCT	DRIFT MANAGEMENT
—	EXCELLENT	EXCELLENT

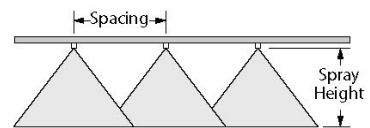

Optimum Spray Height

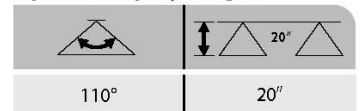

XRC TeeJet® Extended Range Flat Spray Tips



Features:

- Excellent spray distribution over a wide range of pressures—15–60 PSI (1–4 bar).
- Ideal for rigs equipped with sprayer controllers.
- Reduces drift at lower pressures, better coverage at higher pressures.
- 80° available in stainless steel (015, 02, 03–06 capacities) and ceramic (02, 03–08 capacities).
- 110° available in stainless steel (025–05 capacities), ceramic (02–08 capacities) and polymer (025–06 capacities).
- XR TeeJet tip molded into Quick TeeJet® cap provides automatic spray alignment.
- Includes tightly fitting washer that stays put and assures a good seal.



At 15 PSI (1 bar) Pressure At 60 PSI (4 bar) Pressure



Model	PSI	DROPSIZE	CAPACITY ONE NOZZLE IN GPM	CAPACITY ONE NOZZLE IN OZ./MIN.	20°										GALLONS PER 1000 SQ. FT.				
					GPA														
					4 MPH	5 MPH	6 MPH	8 MPH	10 MPH	12 MPH	15 MPH	20 MPH	2 MPH	3 MPH	4 MPH	5 MPH			
XRC80015 (100)	15	M	0.092	12	6.8	5.5	4.6	3.4	2.7	2.3	1.8	1.4	0.31	0.21	0.16	0.13			
	20	M	0.11	14	8.2	6.5	5.4	4.1	3.3	2.7	2.2	1.6	0.37	0.25	0.19	0.15			
	30	F	0.13	17	9.7	7.7	6.4	4.8	3.9	3.2	2.6	1.9	0.44	0.29	0.22	0.18			
	40	F	0.15	19	11.1	8.9	7.4	5.6	4.5	3.7	3.0	2.2	0.51	0.34	0.26	0.20			
	50	F	0.17	22	12.6	10.1	8.4	6.3	5.0	4.2	3.4	2.5	0.58	0.39	0.29	0.23			
XRC8002 XRC11002 (50)	15	M	0.12	15	8.9	7.1	5.9	4.5	3.6	3.0	2.4	1.8	0.41	0.27	0.20	0.16			
	20	M	0.14	18	10.4	8.3	6.9	5.2	4.2	3.5	2.8	2.1	0.48	0.32	0.24	0.19			
	30	F	0.17	22	12.6	10.1	8.4	6.3	5.0	4.2	3.4	2.5	0.58	0.39	0.29	0.23			
	40	F	0.20	26	14.9	11.9	9.9	7.4	5.9	5.0	4.0	3.0	0.68	0.45	0.34	0.27			
	50	F	0.22	28	16.3	13.1	10.9	8.2	6.5	5.4	4.4	3.3	0.75	0.50	0.37	0.30			
XRC110025 (50)	15	M	0.15	19	11.1	8.9	7.4	5.6	4.5	3.7	3.0	2.2	0.51	0.34	0.26	0.20			
	20	M	0.18	23	13.4	10.7	8.9	6.7	5.3	4.5	3.6	2.7	0.61	0.41	0.31	0.24			
	30	F	0.22	28	16.3	13.1	10.9	8.2	6.5	5.4	4.4	3.3	0.75	0.50	0.37	0.30			
	40	F	0.25	32	18.6	14.9	12.4	9.3	7.4	6.2	5.0	3.7	0.85	0.57	0.43	0.34			
	50	F	0.28	36	21	16.6	13.9	10.4	8.3	6.9	5.5	4.2	0.95	0.63	0.48	0.38			
XRC8003 XRC11003 (50)	15	M	0.18	23	13.4	10.7	8.9	6.7	5.3	4.5	3.6	2.7	0.61	0.41	0.31	0.24			
	20	M	0.21	27	15.6	12.5	10.4	7.8	6.2	5.2	4.2	3.1	0.71	0.48	0.36	0.29			
	30	F	0.26	33	19.3	15.4	12.9	9.7	7.7	6.4	5.1	3.9	0.88	0.59	0.44	0.35			
	40	F	0.30	38	22	17.8	14.9	11.1	8.9	7.4	5.9	4.5	1.0	0.68	0.51	0.41			
	50	F	0.34	44	25	20	16.8	12.6	10.1	8.4	6.7	5.0	1.2	0.77	0.58	0.46			
XRC8004 XRC11004 (50)	15	C	0.24	31	17.8	14.3	11.9	8.9	7.1	5.9	4.8	3.6	0.82	0.54	0.41	0.33			
	20	C	0.28	36	21	16.6	13.9	10.4	8.3	6.9	5.5	4.2	0.95	0.63	0.48	0.38			
	30	M	0.35	45	26	21	17.3	13.0	10.4	8.7	6.9	5.2	1.2	0.79	0.60	0.48			
	40	M	0.40	51	30	24	19.8	14.9	11.9	9.9	7.9	5.9	1.4	0.91	0.68	0.54			
	50	M	0.45	58	33	27	22	16.7	13.4	11.1	8.9	6.7	1.5	1.0	0.77	0.61			
XRC8005 XRC11005 (50)	15	C	0.31	40	23	18.4	15.3	11.5	9.2	7.7	6.1	4.6	1.1	0.70	0.53	0.42			
	20	C	0.35	45	26	21	17.3	13.0	10.4	8.7	6.9	5.2	1.2	0.79	0.60	0.48			
	30	C	0.43	55	32	26	21	16.0	12.8	10.6	8.5	6.4	1.5	0.97	0.73	0.58			
	40	M	0.50	64	37	30	25	18.6	14.9	12.4	9.9	7.4	1.7	1.1	0.85	0.68			
	50	M	0.56	72	42	33	28	21	16.6	13.9	11.1	8.3	1.9	1.3	0.95	0.76			
XRC8006 XRC11006 (50)	15	C	0.37	47	27	22	18.3	13.7	11.0	9.2	7.3	5.5	1.3	0.84	0.63	0.50			
	20	C	0.42	54	31	25	21	15.6	12.5	10.4	8.3	6.2	1.4	0.95	0.71	0.57			
	30	C	0.52	67	39	31	26	19.3	15.4	12.9	10.3	7.7	1.8	1.2	0.88	0.71			
	40	C	0.60	77	45	36	30	22	17.8	14.9	11.9	8.9	2.0	1.4	1.0	0.82			
	50	C	0.67	86	50	40	33	25	19.9	16.6	13.3	9.9	2.3	1.5	1.1	0.91			
XRC8008 XRC11008 (50)	15	VC	0.49	63	36	29	24	18.2	14.6	12.1	9.7	7.3	1.7	1.1	0.83	0.67			
	20	VC	0.57	73	42	34	28	21	16.9	14.1	11.3	8.5	1.9	1.3	0.97	0.78			
	30	C	0.69	88	51	41	34	26	20	17.1	13.7	10.2	2.3	1.6	1.2	0.94			
	40	C	0.80	102	59	48	40	30	24	19.8	15.8	11.9	2.7	1.8	1.4	1.1			
	50	C	0.89	114	66	53	44	33	26	22	17.6	13.2	3.0	2.0	1.5	1.2			
60	C	0.98	125	73	58	49	36	29	24	19.4	14.6	3.3	2.2	1.7	1.3				

Note: Always double check your application rates. Tabulations are based on spraying water at 70°F (21°C).



CONTACT PRODUCT	SYSTEMIC PRODUCT	DRIFT MANAGEMENT
EXCELLENT	GOOD	GOOD
GOOD#	VERY GOOD*	VERY GOOD*

*At pressures below 30 PSI (2.0 bar)

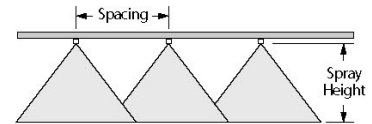

Optimum Spray Height

80°	30"
110°	20"



AIXR TeeJet® Air Induction XR Flat Spray Tips

Features:

- 110° wide, tapered flat spray angle with air induction technology offers better drift management.
- Made of a two-piece UHMWPE polymer construction with VisiFlo® color-coding. UHMWPE provides excellent chemical resistance, including acids, as well as exceptional wear life.

- Compact size to prevent tip damage.
- Depending on the chemical, produces large air-filled drops through a Venturi air aspirator.
- Removable pre-orifice.
- Available in seven tip capacities with a wide operating pressure range: 15–90 PSI (1–6 bar).
- Automatic alignment when used with Quick TeeJet® cap and gasket.



PSI	CAPACITY ONE NOZZLE IN GPM	CAPACITY ONE NOZZLE IN OZ./MIN.	20°																		
			GPA								GALLONS PER 1000 SQ. FT.										
			4 MPH	5 MPH	6 MPH	8 MPH	10 MPH	12 MPH	15 MPH	20 MPH	2 MPH	3 MPH	4 MPH	5 MPH							
15	0.092	12	6.8	5.5	4.6	3.4	2.7	2.3	1.8	1.4	0.31	0.21	0.16	0.13							
20	0.11	14	8.2	6.5	5.4	4.1	3.3	2.7	2.2	1.6	0.37	0.25	0.19	0.15							
30	0.13	17	9.7	7.7	6.4	4.8	3.9	3.2	2.6	1.9	0.44	0.29	0.22	0.18							
40	0.15	19	11.1	8.9	7.4	5.6	4.5	3.7	3.0	2.2	0.51	0.34	0.26	0.20							
50	0.17	22	12.6	10.1	8.4	6.3	5.0	4.2	3.4	2.5	0.58	0.39	0.29	0.23							
60	0.18	23	13.4	10.7	8.9	6.7	5.3	4.5	3.6	2.7	0.61	0.41	0.31	0.24							
75	0.21	27	15.6	12.5	10.4	7.8	6.2	5.2	4.2	3.1	0.71	0.48	0.36	0.29							
90	0.23	29	17.1	13.7	11.4	8.5	6.8	5.7	4.6	3.4	0.78	0.52	0.39	0.31							
15	0.12	15	8.9	7.1	5.9	4.5	3.6	3.0	2.4	1.8	0.41	0.27	0.20	0.16							
20	0.14	18	10.4	8.3	6.9	5.2	4.2	3.5	2.8	2.1	0.48	0.32	0.24	0.19							
30	0.17	22	12.6	10.1	8.4	6.3	5.0	4.2	3.4	2.5	0.58	0.39	0.29	0.23							
40	0.20	26	14.9	11.9	9.9	7.4	5.9	5.0	4.0	3.0	0.68	0.45	0.34	0.27							
50	0.22	28	16.3	13.1	10.9	8.2	6.5	5.4	4.4	3.3	0.75	0.50	0.37	0.30							
60	0.24	31	17.8	14.3	11.9	8.9	7.1	5.9	4.8	3.6	0.82	0.54	0.41	0.33							
75	0.27	35	20	16.0	13.4	10.0	8.0	6.7	5.3	4.0	0.92	0.61	0.46	0.37							
90	0.30	38	22	17.8	14.9	11.1	8.9	7.4	5.9	4.5	1.0	0.68	0.51	0.41							
15	0.15	19	11.1	8.9	7.4	5.6	4.5	3.7	3.0	2.2	0.51	0.34	0.26	0.20							
20	0.18	23	13.4	10.7	8.9	6.7	5.3	4.5	3.6	2.7	0.61	0.41	0.31	0.24							
30	0.22	28	16.3	13.1	10.9	8.2	6.5	5.4	4.4	3.3	0.75	0.50	0.37	0.30							
40	0.25	32	18.6	14.9	12.4	9.3	7.4	6.2	5.0	3.7	0.85	0.57	0.43	0.34							
50	0.28	36	21	16.6	13.9	10.4	8.3	6.9	5.5	4.2	0.95	0.63	0.48	0.38							
60	0.31	40	23	18.4	15.3	11.5	9.2	7.7	6.1	4.6	1.1	0.70	0.53	0.42							
75	0.34	44	25	20	16.8	12.6	10.1	8.4	6.7	5.0	1.2	0.77	0.58	0.46							
90	0.38	49	28	23	18.8	14.1	11.3	9.4	7.5	5.6	1.3	0.86	0.65	0.52							
15	0.18	23	13.4	10.7	8.9	6.7	5.3	4.5	3.6	2.7	0.61	0.41	0.31	0.24							
20	0.21	27	15.6	12.5	10.4	7.8	6.2	5.2	4.2	3.1	0.71	0.48	0.36	0.29							
30	0.26	33	19.3	15.4	12.9	9.7	7.7	6.4	5.1	3.9	0.88	0.59	0.44	0.35							
40	0.30	38	22	17.8	14.9	11.1	8.9	7.4	5.9	4.5	1.0	0.68	0.51	0.41							
50	0.34	44	25	20	16.8	12.6	10.1	8.4	6.7	5.0	1.2	0.77	0.58	0.46							
60	0.37	47	27	22	18.3	13.7	11.0	9.2	7.3	5.5	1.3	0.84	0.63	0.50							
75	0.41	52	30	24	20	15.2	12.2	10.1	8.1	6.1	1.4	0.93	0.70	0.56							
90	0.45	58	33	27	22	16.7	13.4	11.1	8.9	6.7	1.5	1.0	0.77	0.61							
15	0.24	31	17.8	14.3	11.9	8.9	7.1	5.9	4.8	3.6	0.82	0.54	0.41	0.33							
20	0.28	36	21	16.6	13.9	10.4	8.3	6.9	5.5	4.2	0.95	0.63	0.48	0.38							
30	0.35	45	26	21	17.3	13.0	10.4	8.7	6.9	5.2	1.2	0.79	0.60	0.48							
40	0.40	51	30	24	19.8	14.9	11.9	9.9	7.9	5.9	1.4	0.91	0.68	0.54							
50	0.45	58	33	27	22	16.7	13.4	11.1	8.9	6.7	1.5	1.0	0.77	0.61							
60	0.49	63	36	29	24	18.2	14.6	12.1	9.7	7.3	1.7	1.1	0.83	0.67							
75	0.55	70	41	33	27	20	16.3	13.6	10.9	8.2	1.9	1.2	0.94	0.75							
90	0.60	77	45	36	30	22	17.8	14.9	11.9	8.9	2.0	1.4	1.0	0.82							
15	0.31	40	23	18.4	15.3	11.5	9.2	7.7	6.1	4.6	1.1	0.70	0.53	0.42							
20	0.35	45	26	21	17.3	13.0	10.4	8.7	6.9	5.2	1.2	0.79	0.60	0.48							
30	0.43	55	32	26	21	16.0	12.8	10.6	8.5	6.4	1.5	0.97	0.73	0.58							
40	0.50	64	37	30	25	18.6	14.9	12.4	9.9	7.4	1.7	1.1	0.85	0.68							
50	0.56	72	42	33	28	21	16.6	13.9	11.1	8.3	1.9	1.3	0.95	0.76							
60	0.61	78	45	36	30	23	18.1	15.1	12.1	9.1	2.1	1.4	1.0	0.83							
75	0.68	87	50	40	34	25	20	16.8	13.5	10.1	2.3	1.5	1.2	0.92							
90	0.75	96	56	45	37	28	22	18.6	14.9	11.1	2.6	1.7	1.3	1.0							
15	0.37	47	27	22	18.3	13.7	11.0	9.2	7.3	5.5	1.3	0.84	0.63	0.50							
20	0.42	54	31	25	21	15.6	12.5	10.4	8.3	6.2	1.4	0.95	0.71	0.57							
30	0.52	67	39	31	26	19.3	15.4	12.9	10.3	7.7	1.8	1.2	0.88	0.71							
40	0.60	77	45	36	30	22	17.8	14.9	11.9	8.9	2.0	1.4	1.0	0.82							
50	0.67	86	50	40	33	25	19.9	16.6	13.3	9.9	2.3	1.5	1.1	0.91							
60	0.73	93	54	43	36	27	22	18.1	14.5	10.8	2.5	1.7	1.2	0.99							
75	0.82	105	61	49	41	30	24	20	16.2	12.2	2.8	1.9	1.4	1.1							
90	0.90	115	67	53	45	33	27	22	17.8	13.4	3.1	2.0	1.5	1.2							

Note: Always double check your application rates. Tabulations are based on spraying water at 70°F (21°C).

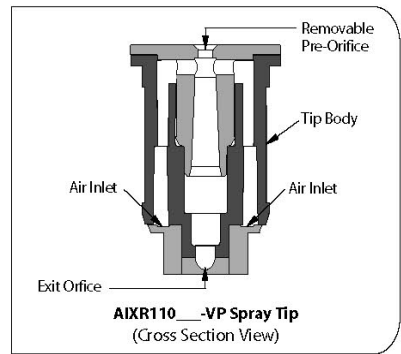

CONTACT PRODUCT	SYSTEMIC PRODUCT	DRIFT MANAGEMENT
GOOD	EXCELLENT	EXCELLENT

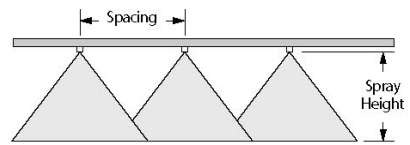

Optimum Spray Height

110°	20"



AIC TeeJet[®] Air Induction Flat Spray Tips

* Please Note *

The **AI TeeJet** Broadcast tip shares the same characteristics (less the pre-molded quick cap) and spray chart as the AIC TeeJet.

Features:

- Produces a 110° tapered edge flat spray pattern for uniform coverage in broadcast spraying applications.
- Available with a polymer insert holder with stainless steel (015–10 capacities), ceramic (025–05 capacities) or polymer (02–05 capacities) inserts.

- Larger droplets for less drift.
- Depending on the chemical, produces large air-filled drops through the use of a Venturi air aspirator.
- AI TeeJet nozzle molded into Quick TeeJet[®] cap provides automatic spray alignment.
- Includes tightly fitting washer that stays put and assures a good seal.
- Recommended pressure rating 30–115 PSI (2–8 bar).



Note: Due to the pre-orifice design, this tip is not compatible with the 4193A check valve tip strainer.

PSI	DROP SIZE	CAPACITY ONE NOZZLE IN GPM	CAPACITY ONE NOZZLE IN OZ./MIN.	20°												GALLONS PER 1000 SQ. FT.			
				GPA															
				4 MPH	5 MPH	6 MPH	8 MPH	10 MPH	12 MPH	15 MPH	20 MPH	2 MPH	3 MPH	4 MPH	5 MPH				
AIC110015 (100)	VC	0.13	17	9.7	7.7	6.4	4.8	3.9	3.2	2.6	1.9	0.44	0.29	0.22	0.18				
	VC	0.15	19	11.1	8.9	7.4	5.6	4.5	3.7	3.0	2.2	0.51	0.34	0.26	0.20				
	VC	0.17	22	12.6	10.1	8.4	6.3	5.0	4.2	3.4	2.5	0.58	0.39	0.29	0.23				
	C	0.18	23	13.4	10.7	8.9	6.7	5.3	4.5	3.6	2.7	0.61	0.41	0.31	0.24				
	C	0.20	26	14.9	11.9	9.9	7.4	5.9	5.0	4.0	3.0	0.68	0.45	0.34	0.27				
AIC11002 (50)	VC	0.17	22	12.6	10.1	8.4	6.3	5.0	4.2	3.4	2.5	0.58	0.39	0.29	0.23				
	VC	0.20	26	14.9	11.9	9.9	7.4	5.9	5.0	4.0	3.0	0.68	0.45	0.34	0.27				
	VC	0.22	28	16.3	13.1	10.9	8.2	6.5	5.4	4.4	3.3	0.75	0.50	0.37	0.30				
	C	0.24	31	17.8	14.3	11.9	8.9	7.1	5.9	4.8	3.6	0.82	0.54	0.41	0.33				
	C	0.26	33	19.3	15.4	12.9	9.7	7.7	6.4	5.1	3.9	0.88	0.59	0.44	0.35				
AIC110025 (50)	VC	0.22	28	16.3	13.1	10.9	8.2	6.5	5.4	4.4	3.3	0.75	0.50	0.37	0.30				
	VC	0.25	32	18.6	14.9	12.4	9.3	7.4	6.2	5.0	3.7	0.85	0.57	0.43	0.34				
	VC	0.28	36	21	16.6	13.9	10.4	8.3	6.9	5.5	4.2	0.95	0.63	0.48	0.38				
	VC	0.31	40	23	18.4	15.3	11.5	9.2	7.7	6.1	4.6	1.1	0.70	0.53	0.42				
	VC	0.33	42	25	19.6	16.3	12.3	9.8	8.2	6.5	4.9	1.1	0.75	0.56	0.45				
AIC11003 (50)	VC	0.26	33	19.3	15.4	12.9	9.7	7.7	6.4	5.1	3.9	0.88	0.59	0.44	0.35				
	VC	0.30	38	22	17.8	14.9	11.1	8.9	7.4	5.9	4.5	1.0	0.68	0.51	0.41				
	VC	0.34	44	25	20	16.8	12.6	10.1	8.4	6.7	5.0	1.2	0.77	0.58	0.46				
	VC	0.37	47	27	22	18.3	13.7	11.0	9.2	7.3	5.5	1.3	0.84	0.63	0.50				
	VC	0.40	51	30	24	19.8	14.9	11.9	9.9	7.9	5.9	1.4	0.91	0.68	0.54				
AIC11004 (50)	VC	0.35	45	26	21	17.3	13.0	10.4	8.7	6.9	5.2	1.2	0.79	0.60	0.48				
	VC	0.40	51	30	24	19.8	14.9	11.9	9.9	7.9	5.9	1.4	0.91	0.68	0.54				
	VC	0.45	58	33	27	22	16.7	13.4	11.1	8.9	6.7	1.5	1.0	0.77	0.61				
	VC	0.49	63	36	29	24	18.2	14.6	12.1	9.7	7.3	1.7	1.1	0.83	0.67				
	VC	0.53	68	39	31	26	19.7	15.7	13.1	10.5	7.9	1.8	1.2	0.90	0.72				
AIC11005 (50)	VC	0.57	73	42	34	28	21	16.9	14.1	11.3	8.5	1.9	1.3	0.97	0.78				
	VC	0.60	77	45	36	30	22	17.8	14.9	11.9	8.9	2.0	1.4	1.0	0.82				
	VC	0.63	81	47	37	31	23	18.7	15.6	12.5	9.4	2.1	1.4	1.1	0.86				
	VC	0.68	89	51	41	34	26	20	17.1	14.1	11.1	2.1	1.5	1.1	0.88				
	VC	0.72	95	54	43	36	28	22	18.1	14.5	11.3	2.2	1.5	1.1	0.90				
AIC11006 (50)	VC	0.77	101	57	46	38	30	23	19.1	15.1	12.1	2.3	1.6	1.2	0.93				
	VC	0.81	107	60	49	41	33	25	20.1	16.1	13.1	2.4	1.7	1.3	0.95				
	VC	0.85	109	63	50	42	34	26	21	17.6	14.1	2.5	1.8	1.4	1.0				
	VC	0.90	115	67	53	45	37	29	22	18.6	14.9	2.6	1.7	1.3	1.0				
	VC	0.95	122	71	56	47	39	29	23	19.6	15.6	2.7	1.8	1.3	1.1				
AIC11008 (50)	VC	0.69	88	51	41	34	26	20	17.1	13.7	10.2	2.3	1.6	1.2	0.94				
	VC	0.80	102	59	48	40	30	24	19.8	15.8	11.9	2.7	1.8	1.4	1.1				
	VC	0.89	114	66	53	44	33	26	22	17.6	13.2	3.0	2.0	1.5	1.2				
	VC	0.98	125	73	58	49	36	29	24	19.4	14.6	3.3	2.2	1.7	1.3				
	VC	1.06	136	79	63	52	39	31	26	21	15.7	3.6	2.4	1.8	1.4				
AIC11010	VC	1.13	145	84	67	56	42	34	28	22	16.8	3.8	2.6	1.9	1.5				
	VC	1.20	154	89	71	59	45	36	30	24	17.8	4.1	2.7	2.0	1.6				
	VC	1.26	161	94	75	62	47	37	31	25	18.7	4.3	2.9	2.1	1.7				
	VC	0.87	111	65	52	43	32	26	22	17.2	12.9	3.0	2.0	1.5	1.2				
	VC	1.00	128	74	59	50	37	30	25	19.8	14.9	3.4	2.3	1.7	1.4				

Note: Always double check your application rates. Tabulations are based on spraying water at 70°F (21°C).

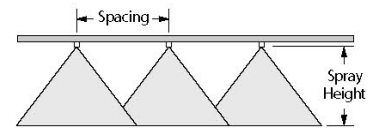

Optimum Spray Height

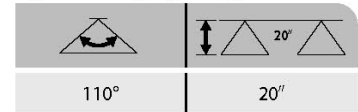

TwinJet® Twin Flat Spray Tips



Features:

- Penetrates crop residue or dense foliage.
- Smaller droplets for thorough coverage.
- Better spray distribution along boom than with hollow cone nozzles.
- Available in stainless steel with VisiFlo® color-coding in 65°, 80° and 110° spray angles.
- Recommended pressure rating 30–60 PSI (2–4 bar).



PSI	DROP SIZE		CAPACITY ONE NOZZLE IN GPM	CAPACITY ONE NOZZLE IN OZ./MIN.	20°										GALLONS PER 1000 SQ. FT.				
	80°	110°			GPA														
					4 MPH	5 MPH	6 MPH	8 MPH	10 MPH	12 MPH	15 MPH	20 MPH	2 MPH	3 MPH	4 MPH	5 MPH			
TJ60-6501 TJ60-8001 (100)	30	VF	0.087	11	6.5	5.2	4.3	3.2	2.6	2.2	1.7	1.3	0.30	0.20	0.15	0.12			
	35	VF	0.094	12	7.0	5.6	4.7	3.5	2.8	2.3	1.9	1.4	0.32	0.21	0.16	0.13			
	40	VF	0.10	13	7.4	5.9	5.0	3.7	3.0	2.5	2.0	1.5	0.34	0.23	0.17	0.14			
	50	VF	0.11	14	8.2	6.5	5.4	4.1	3.3	2.7	2.2	1.6	0.37	0.25	0.19	0.15			
	60	VF	0.12	15	8.9	7.1	5.9	4.5	3.6	3.0	2.4	1.8	0.41	0.27	0.20	0.16			
TJ60-650134 (100)	30		0.12	15	8.9	7.1	5.9	4.5	3.6	3.0	2.4	1.8	0.41	0.27	0.20	0.16			
	35		0.13	17	9.7	7.7	6.4	4.8	3.9	3.2	2.6	1.9	0.44	0.29	0.22	0.18			
	40		0.134	17	9.9	8.0	6.6	5.0	4.0	3.3	2.7	2.0	0.46	0.30	0.23	0.18			
	50		0.15	19	11.1	8.9	7.4	5.6	4.5	3.7	3.0	2.2	0.51	0.34	0.26	0.20			
	60		0.16	20	11.9	9.5	7.9	5.9	4.8	4.0	3.2	2.4	0.54	0.36	0.27	0.22			
TJ60-6502 TJ60-8002 TJ60-11002 (100)	30	F	0.17	22	12.6	10.1	8.4	6.3	5.0	4.2	3.4	2.5	0.58	0.39	0.29	0.23			
	35	F	0.19	24	14.1	11.3	9.4	7.1	5.6	4.7	3.8	2.8	0.65	0.43	0.32	0.26			
	40	F	0.20	26	14.9	11.9	9.9	7.4	5.9	5.0	4.0	3.0	0.68	0.45	0.34	0.27			
	50	F	0.22	28	16.3	13.1	10.9	8.2	6.5	5.4	4.4	3.3	0.75	0.50	0.37	0.30			
	60	F	0.24	31	17.8	14.3	11.9	8.9	7.1	5.9	4.8	3.6	0.82	0.54	0.41	0.33			
TJ60-6503 TJ60-8003 TJ60-11003 (100)	30	F	0.26	33	19.3	15.4	12.9	9.7	7.7	6.4	5.1	3.9	0.88	0.59	0.44	0.35			
	35	F	0.28	36	21	16.6	13.9	10.4	8.3	6.9	5.5	4.2	0.95	0.63	0.48	0.38			
	40	F	0.30	38	22	17.8	14.9	11.1	8.9	7.4	5.9	4.5	1.0	0.68	0.51	0.41			
	50	F	0.34	44	25	20	16.8	12.6	10.1	8.4	6.7	5.0	1.2	0.77	0.58	0.46			
	60	F	0.37	47	27	22	18.3	13.7	11.0	9.2	7.3	5.5	1.3	0.84	0.63	0.50			
TJ60-6504 TJ60-8004 TJ60-11004 (50)	30	M	0.35	45	26	21	17.3	13.0	10.4	8.7	6.9	5.2	1.2	0.79	0.60	0.48			
	35	M	0.37	47	27	22	18.3	13.7	11.0	9.2	7.3	5.5	1.3	0.84	0.63	0.50			
	40	F	0.40	51	30	24	19.8	14.9	11.9	9.9	7.9	5.9	1.4	0.91	0.68	0.54			
	50	F	0.45	58	33	27	22	16.7	13.4	11.1	8.9	6.7	1.5	1.0	0.77	0.61			
	60	F	0.49	63	36	29	24	18.2	14.6	12.1	9.7	7.3	1.7	1.1	0.83	0.67			
TJ60-8005 TJ60-11005 (50)	30	M	0.43	55	32	26	21	16.0	12.8	10.6	8.5	6.4	1.5	0.97	0.73	0.58			
	35	M	0.47	60	35	28	23	17.4	14.0	11.6	9.3	7.0	1.6	1.07	0.80	0.64			
	40	M	0.50	64	37	30	25	18.6	14.9	12.4	9.9	7.4	1.7	1.13	0.85	0.68			
	50	F	0.56	72	42	33	28	21	16.6	13.9	11.1	8.3	1.9	1.3	0.95	0.76			
	60	F	0.61	78	45	36	30	23	18.1	15.1	12.1	9.1	2.1	1.4	1.04	0.83			
TJ60-6506 TJ60-8006 TJ60-11006 (50)	30	M	0.52	67	39	31	26	19.3	15.4	12.9	10.3	7.7	1.8	1.2	0.88	0.71			
	35	M	0.56	72	42	33	28	21	16.6	13.9	11.1	8.3	1.9	1.3	0.95	0.76			
	40	M	0.60	77	45	36	30	22	17.8	14.9	11.9	8.9	2.0	1.4	1.0	0.82			
	50	M	0.67	86	50	40	33	25	19.9	16.6	13.3	9.9	2.3	1.5	1.1	0.91			
	60	M	0.73	93	54	43	36	27	22	18.1	14.5	10.8	2.5	1.7	1.2	0.99			
TJ60-6508 TJ60-8008 TJ60-11008 (50)	30	C	0.69	88	51	41	34	26	20	17.1	13.7	10.2	2.3	1.6	1.2	0.94			
	35	M	0.75	96	56	45	37	28	22	18.6	14.9	11.1	2.6	1.7	1.3	1.0			
	40	M	0.80	102	59	48	40	30	24	19.8	15.8	11.9	2.7	1.8	1.4	1.1			
	50	M	0.89	114	66	53	44	33	26	22	17.6	13.2	3.0	2.0	1.5	1.2			
	60	M	0.98	125	73	58	49	36	29	24	19.4	14.6	3.3	2.2	1.7	1.3			
TJ60-8010 TJ60-11010 (50)	30	C	0.87	111	65	52	43	32	26	22	17.2	12.9	3.0	2.0	1.5	1.2			
	35	C	0.94	120	70	56	47	35	28	23	18.6	14.0	3.2	2.1	1.6	1.3			
	40	C	1.00	128	74	59	50	37	30	25	19.8	14.9	3.4	2.3	1.7	1.4			
	50	M	1.12	143	83	67	55	42	33	28	22	16.6	3.8	2.5	1.9	1.5			
	60	M	1.22	156	91	72	60	45	36	30	24	18.1	4.1	2.8	2.1	1.7			

Note: Always double check your application rates. Tabulations are based on spraying water at 70°F (21°C).



CONTACT PRODUCT	SYSTEMIC PRODUCT	DRIFT MANAGEMENT
EXCELLENT	—	—

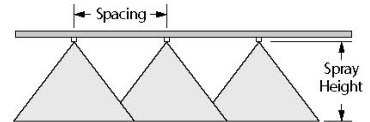

Optimum Spray Height

Spray Angle	Optimum Spray Height
65°	35"
80°	30"
110°	20"

BROADCAST NOZZLES



DG TwinJet® Drift Guard Twin Flat Spray Tips

Features:

- Dual 110°, tapered edge, flat fan spray patterns spraying 60° forward to back providing uniform coverage in broadcast spraying applications.
- DG TwinJet offers larger droplets and improved drift control compared to a standard TwinJet spray tip of equal capacity.
- Dual angled spray patterns help to better penetrate crop canopy and provide thorough leaf coverage.
- Made of stainless steel with VisiFlo® color-coding for excellent chemical and wear resistance.
- Removable polymer pre-orifice.
- Available in six capacities with a recommended pressure range of 30–60 PSI (2–4 bar).
- Automatic spray alignment when used with Quick TeeJet® cap and gasket.

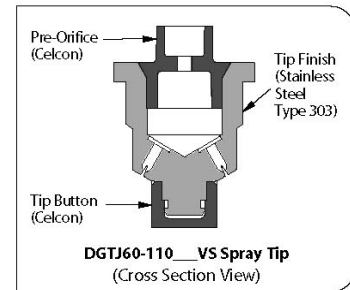

Note: Due to pre-orifice design, this tip is not compatible with the 4193A check valve tip strainer.

Icon	PSI	DROP SIZE	CAPACITY ONE NOZZLE IN GPM	CAPACITY ONE NOZZLE IN OZ./MIN.	20°														
					GPA										GALLONS PER 1000 SQ. FT.				
					4 MPH	5 MPH	6 MPH	8 MPH	10 MPH	12 MPH	15 MPH	20 MPH	2 MPH	3 MPH	4 MPH	5 MPH			
DGTJ60-110015 (100)	30	F	0.13	17	9.7	7.7	6.4	4.8	3.9	3.2	2.6	1.9	0.44	0.29	0.22	0.18			
	35	F	0.14	18	10.4	8.3	6.9	5.2	4.2	3.5	2.8	2.1	0.48	0.32	0.24	0.19			
	40	F	0.15	19	11.1	8.9	7.4	5.6	4.5	3.7	3.0	2.2	0.51	0.34	0.26	0.20			
	50	F	0.17	22	12.6	10.1	8.4	6.3	5.0	4.2	3.4	2.5	0.58	0.39	0.29	0.23			
	60	F	0.18	23	13.4	10.7	8.9	6.7	5.3	4.5	3.6	2.7	0.61	0.41	0.31	0.24			
DGTJ60-11002 (100)	30	M	0.17	22	12.6	10.1	8.4	6.3	5.0	4.2	3.4	2.5	0.58	0.39	0.29	0.23			
	35	M	0.19	24	14.1	11.3	9.4	7.1	5.6	4.7	3.8	2.8	0.65	0.43	0.32	0.26			
	40	M	0.20	26	14.9	11.9	9.9	7.4	5.9	5.0	4.0	3.0	0.68	0.45	0.34	0.27			
	50	F	0.22	28	16.3	13.1	10.9	8.2	6.5	5.4	4.4	3.3	0.75	0.50	0.37	0.30			
	60	F	0.24	31	17.8	14.3	11.9	8.9	7.1	5.9	4.8	3.6	0.82	0.54	0.41	0.33			
DGTJ60-11003 (100)	30	C	0.26	33	19.3	15.4	12.9	9.7	7.7	6.4	5.1	3.9	0.88	0.59	0.44	0.35			
	35	M	0.28	36	21	16.6	13.9	10.4	8.3	6.9	5.5	4.2	0.95	0.63	0.48	0.38			
	40	M	0.30	38	22	17.8	14.9	11.1	8.9	7.4	5.9	4.5	1.0	0.68	0.51	0.41			
	50	M	0.34	44	25	20	16.8	12.6	10.1	8.4	6.7	5.0	1.2	0.77	0.58	0.46			
	60	M	0.37	47	27	22	18.3	13.7	11.0	9.2	7.3	5.5	1.3	0.84	0.63	0.50			
DGTJ60-11004 (50)	30	C	0.35	45	26	21	17.3	13.0	10.4	8.7	6.9	5.2	1.2	0.79	0.60	0.48			
	35	C	0.37	47	27	22	18.3	13.7	11.0	9.2	7.3	5.5	1.3	0.84	0.63	0.50			
	40	C	0.40	51	30	24	19.8	14.9	11.9	9.9	7.9	5.9	1.4	0.91	0.68	0.54			
	50	C	0.45	58	33	27	22	16.7	13.4	11.1	8.9	6.7	1.5	1.0	0.77	0.61			
	60	M	0.49	63	36	29	24	18.2	14.6	12.1	9.7	7.3	1.7	1.1	0.83	0.67			
DGTJ60-11006 (50)	30	C	0.52	67	39	31	26	19.3	15.4	12.9	10.3	7.7	1.8	1.2	0.88	0.71			
	35	C	0.56	72	42	33	28	21	16.6	13.9	11.1	8.3	1.9	1.3	0.95	0.76			
	40	C	0.60	77	45	36	30	22	17.8	14.9	11.9	8.9	2.0	1.4	1.0	0.82			
	50	C	0.67	86	50	40	33	25	19.9	16.6	13.3	9.9	2.3	1.5	1.1	0.91			
	60	C	0.73	93	54	43	36	27	22	18.1	14.5	10.8	2.5	1.7	1.2	0.99			
DGTJ60-11008 (50)	30	C	0.69	88	51	41	34	26	20	17.1	13.7	10.2	2.3	1.6	1.2	0.94			
	35	C	0.75	96	56	45	37	28	22	18.6	14.9	11.1	2.6	1.7	1.3	1.0			
	40	C	0.80	102	59	48	40	30	24	19.8	15.8	11.9	2.7	1.8	1.4	1.1			
	50	C	0.89	114	66	53	44	33	26	22	17.6	13.2	3.0	2.0	1.5	1.2			
	60	C	0.98	125	73	58	49	36	29	24	19.4	14.6	3.3	2.2	1.7	1.3			

Note: Always double check your application rates. Tabulations are based on spraying water at 70°F (21°C).



CONTACT PRODUCT	SYSTEMIC PRODUCT	DRIFT MANAGEMENT
VERY GOOD	EXCELLENT	VERY GOOD

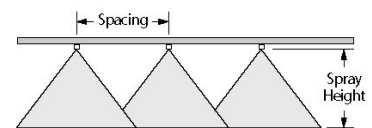

Optimum Spray Height

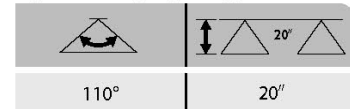

Turbo TeeJet Duo Dual Polymer Flat Fan Spray Tips



Features:

- Two Turbo TeeJet tapered edge flat fan spray tips using a QJ90-2-NYR adapter to produce a twin-type pattern spraying forward and back.
- Provides more versatility than the standard twin-type spray tip. Depending on the

Turbo TeeJet tip orientation, a 60°, 90° or 120° included angle can be achieved.

- Best suited for broadcast spraying where superior leaf coverage and canopy penetration is important.
- QJ90 adapter and Quick TeeJet® caps are made of nylon. Turbo TeeJet tips are made of Acetal for excellent wear life and chemical resistance.
- Ideal for use with automatic sprayer controls.

- Recommended operating pressure range is 15–90 PSI (1–6 bar).
- Quick TeeJet caps (included) are colored to match the VisiFlo® color-coding of spray tips.



PSI	DROPS SIZE	CAPACITY ONE TT DUO IN GPM	CAPACITY ONE TT DUO IN OZ./MIN.	20°															
				GPA												GALLONS PER 1000 SQ. FT.			
				4 MPH	5 MPH	6 MPH	8 MPH	10 MPH	12 MPH	15 MPH	20 MPH	2 MPH	3 MPH	4 MPH	5 MPH				
QJ90-2XTT11001 (100)	15 C	0.12	15	8.9	7.1	5.9	4.5	3.6	3.0	2.4	1.8	0.41	0.27	0.20	0.16				
	20 M	0.14	18	10.4	8.3	6.9	5.2	4.2	3.5	2.8	2.1	0.48	0.32	0.24	0.19				
	30 M	0.17	22	12.6	10.1	8.4	6.3	5.0	4.2	3.4	2.5	0.58	0.39	0.29	0.23				
	40 M	0.20	26	14.9	11.9	9.9	7.4	5.9	5.0	4.0	3.0	0.68	0.45	0.34	0.27				
	50 F	0.22	28	16.3	13.1	10.9	8.2	6.5	5.4	4.4	3.3	0.75	0.50	0.37	0.30				
	60 F	0.24	31	17.8	14.3	11.9	8.9	7.1	5.9	4.8	3.6	0.82	0.54	0.41	0.33				
QJ90-2XTT110015 (100)	15 C	0.18	23	13.4	10.7	8.9	6.7	5.3	4.5	3.6	2.7	0.61	0.41	0.31	0.24				
	20 C	0.21	27	15.6	12.5	10.4	7.8	6.2	5.2	4.2	3.1	0.71	0.48	0.36	0.29				
	30 M	0.26	33	19.3	15.4	12.9	9.7	7.7	6.4	5.1	3.9	0.88	0.59	0.44	0.35				
	40 M	0.30	38	22	17.8	14.9	11.1	8.9	7.4	5.9	4.5	1.0	0.68	0.51	0.41				
	50 M	0.34	44	25	20	16.8	12.6	10.1	8.4	6.7	5.0	1.2	0.77	0.58	0.46				
	60 M	0.37	47	27	22	18.3	13.7	11.0	9.2	7.3	5.5	1.3	0.84	0.63	0.50				
QJ90-2XTT11002 (50)	15 C	0.24	31	17.8	14.3	11.9	8.9	7.1	5.9	4.8	3.6	0.82	0.54	0.41	0.33				
	20 C	0.28	36	21	16.6	13.9	10.4	8.3	6.9	5.5	4.2	0.95	0.63	0.48	0.38				
	30 M	0.35	45	26	21	17.3	13.0	10.4	8.7	6.9	5.2	1.2	0.79	0.60	0.48				
	40 M	0.40	51	30	24	19.8	14.9	11.9	9.9	7.9	5.9	1.4	0.91	0.68	0.54				
	50 M	0.45	58	33	27	22	16.7	13.4	11.1	8.9	6.7	1.5	1.0	0.77	0.61				
	60 M	0.49	63	36	29	24	18.2	14.6	12.1	9.7	7.3	1.7	1.1	0.83	0.67				
QJ90-2XTT110025 (50)	15 VC	0.31	40	23	18.4	15.3	11.5	9.2	7.7	6.1	4.6	1.1	0.70	0.53	0.42				
	20 C	0.35	45	26	21	17.3	13.0	10.4	8.7	6.9	5.2	1.2	0.79	0.60	0.48				
	30 C	0.43	55	32	26	21	16.0	12.8	10.6	8.5	6.4	1.5	0.97	0.73	0.58				
	40 M	0.50	64	37	30	25	18.6	14.9	12.4	9.9	7.4	1.7	1.1	0.85	0.68				
	50 M	0.56	72	42	33	28	21	16.6	13.9	11.1	8.3	1.9	1.3	0.95	0.76				
	60 M	0.61	78	45	36	30	23	18.1	15.1	12.1	9.1	2.1	1.4	1.0	0.83				
QJ90-2XTT11003 (50)	15 VC	0.37	47	27	22	18.3	13.7	11.0	9.2	7.3	5.5	1.3	0.84	0.63	0.50				
	20 VC	0.42	54	31	25	21	15.6	12.5	10.4	8.3	6.2	1.4	0.95	0.71	0.57				
	30 C	0.52	67	39	31	26	19.3	15.4	12.9	10.3	7.7	1.8	1.2	0.88	0.71				
	40 C	0.60	77	45	36	30	22	17.8	14.9	11.9	8.9	2.0	1.4	1.0	0.82				
	50 M	0.67	86	50	40	33	25	19.9	16.6	13.3	9.9	2.3	1.5	1.1	0.91				
	60 M	0.73	93	54	43	36	27	22	18.1	14.5	10.8	2.5	1.7	1.2	0.99				
QJ90-2XTT11004 (50)	15 VC	0.49	63	36	29	24	18.2	14.6	12.1	9.7	7.3	1.7	1.1	0.83	0.67				
	20 VC	0.57	73	42	34	28	21	16.9	14.1	11.3	8.5	1.9	1.3	0.97	0.78				
	30 C	0.69	88	51	41	34	26	20	17.1	13.7	10.2	2.3	1.6	1.2	0.94				
	40 C	0.80	102	59	48	40	30	24	19.8	15.8	11.9	2.7	1.8	1.4	1.1				
	50 C	0.89	114	66	53	44	33	26	22	17.6	13.2	3.0	2.0	1.5	1.2				
	60 C	0.98	125	73	58	49	36	29	24	19.4	14.6	3.3	2.2	1.7	1.3				
QJ90-2XTT11005 (50)	15 VC	1.10	141	82	65	54	41	33	27	22	16.3	3.7	2.5	1.9	1.5				
	20 VC	1.20	154	89	71	59	45	36	30	24	17.8	4.1	2.7	2.0	1.6				
	30 VC	0.61	78	45	36	30	23	18.1	15.1	12.1	9.1	2.1	1.4	1.0	0.83				
	40 VC	0.71	91	53	42	35	26	21	17.6	14.1	10.5	2.4	1.6	1.2	0.97				
	50 C	0.87	111	65	52	43	32	26	22	17.2	12.9	3.0	2.0	1.5	1.2				
	60 C	1.00	128	74	59	50	37	30	25	19.8	14.9	3.4	2.3	1.7	1.4				
QJ90-2XTT11006 (50)	15 VC	1.12	143	83	67	55	42	33	28	22	16.6	3.8	2.5	1.9	1.5				
	20 VC	1.22	156	91	72	60	45	36	30	24	18.1	4.1	2.8	2.1	1.7				
	30 VC	1.37	175	102	81	68	51	41	34	27	20	4.7	3.1	2.3	1.9				
	40 VC	1.50	192	111	89	74	56	45	37	30	22	5.1	3.4	2.6	2.0				
	50 VC	0.73	93	54	43	36	27	22	18.1	14.5	10.8	2.5	1.7	1.2	0.99				
	60 VC	0.85	109	63	50	42	32	25	21	16.8	12.6	2.9	1.9	1.4	1.2				
QJ90-2XTT11008 (50)	15 VC	1.04	133	77	62	51	39	31	26	21	15.4	3.5	2.4	1.8	1.4				
	20 VC	1.20	154	89	71	59	45	36	30	24	17.8	4.1	2.7	2.0	1.6				
	30 VC	1.34	172	99	80	66	50	40	33	27	19.9	4.6	3.0	2.3	1.8				
	40 VC	1.47	188	109	87	73	55	44	36	29	22	5.0	3.3	2.5	2.0				
	50 VC	1.64	210	122	97	81	61	49	41	32	24	5.6	3.7	2.8	2.2				
	60 VC	1.80	230	134	107	89	67	53	45	36	27	6.1	4.1	3.1	2.4				

Note: Always double check your application rates. Tabulations are based on spraying water at 70°F (21°C).



CONTACT PRODUCT	SYSTEMIC PRODUCT	DRIFT MANAGEMENT
EXCELLENT	EXCELLENT	VERY GOOD
VERY GOOD*	EXCELLENT*	EXCELLENT*

*At pressures below 30 PSI (2.0 bar)

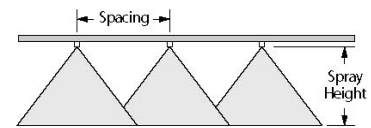

Optimum Spray Height



TeeJet® VisiFlo® Flat Spray Tips

Features:

- Tapered edge flat spray pattern for uniform coverage in broadcast spraying.
- VisiFlo color-coded version available in stainless steel, ceramic and polymer in 80° or 110° spray angles in selected sizes.
- Available in ceramic 80° capacities 01-02 and 110° capacities 01-015.
- Standard version (not color-coded) available in 15°, 25°, 40°, 50° and 65° spray angles in brass, stainless steel or hardened stainless steel.
- Automatic spray alignment with Quick TeeJet® cap and gasket.



NOZZLE	PSI	DROPSIZE	CAPACITY ONE NOZZLE IN GPM	CAPACITY ONE NOZZLE IN OZ./MIN.	20°												GALLONS PER 1000 SQ. FT.			
					GPA												GALLONS PER 1000 SQ. FT.			
					4 MPH	5 MPH	6 MPH	8 MPH	10 MPH	12 MPH	15 MPH	20 MPH	2 MPH	3 MPH	4 MPH	5 MPH				
TP650050†	30		0.043	5.5	3.2	2.6	2.1	1.6	1.3	1.1	0.85	0.64	0.15	0.10	0.07	0.06				
TP800050†	35		0.047	6.0	3.5	2.8	2.3	1.7	1.4	1.2	0.93	0.70	0.16	0.11	0.08	0.06				
TP1100050†	40		0.050	6.4	3.7	3.0	2.5	1.9	1.5	1.2	0.99	0.74	0.17	0.11	0.09	0.07				
TP650067†	30		0.058	7.4	4.3	3.4	2.9	2.2	1.7	1.4	1.1	0.86	0.20	0.13	0.10	0.08				
TP800067†	35		0.063	8.1	4.7	3.7	3.1	2.3	1.9	1.6	1.2	0.94	0.21	0.14	0.11	0.09				
TP1100067†	40		0.067	8.6	5.0	4.0	3.3	2.5	2.0	1.7	1.3	0.99	0.23	0.15	0.11	0.09				
TP6501†	30	F	0.087	11	6.5	5.2	4.3	3.2	2.6	2.2	1.7	1.3	0.30	0.20	0.15	0.12				
TP8001	35	F	0.094	12	7.0	5.6	4.7	3.5	2.8	2.3	1.9	1.4	0.32	0.21	0.16	0.13				
TP11001	40	F	0.10	13	7.4	5.9	5.0	3.7	3.0	2.5	2.0	1.5	0.34	0.23	0.17	0.14				
TP65015†	30	F	0.13	17	9.7	7.7	6.4	4.8	3.9	3.2	2.6	1.9	0.44	0.29	0.22	0.18				
TP80015	35	F	0.14	18	10.4	8.3	6.9	5.2	4.2	3.5	2.8	2.1	0.48	0.32	0.24	0.19				
TP110015	40	F	0.15	19	11.1	8.9	7.4	5.6	4.5	3.7	3.0	2.2	0.51	0.34	0.26	0.20				
TP6502†	30	M	0.17	22	12.6	10.1	8.4	6.3	5.0	4.2	3.4	2.5	0.58	0.39	0.29	0.23				
TP8002	35	M	0.19	24	14.1	11.3	9.4	7.1	5.6	4.7	3.8	2.8	0.65	0.43	0.32	0.26				
TP11002	40	F	0.20	26	14.9	11.9	9.9	7.4	5.9	5.0	4.0	3.0	0.68	0.45	0.34	0.27				
TP6503†	30	M	0.26	31	17.8	14.3	11.9	8.9	7.1	5.9	4.8	3.6	0.82	0.54	0.41	0.33				
TP8003	35	M	0.28	33	19.3	15.4	12.9	9.7	7.7	6.4	5.1	3.9	0.88	0.59	0.44	0.35				
TP11003	40	M	0.30	38	22	17.8	14.9	11.1	8.9	7.4	5.9	4.5	1.0	0.68	0.51	0.41				
TP6504†	30	M	0.35	45	26	21	17.3	13.0	10.4	8.7	6.9	5.2	1.2	0.79	0.60	0.48				
TP8004	35	M	0.37	47	27	22	18.3	13.7	11.0	9.2	7.3	5.5	1.3	0.84	0.63	0.50				
TP11004	40	M	0.40	51	30	24	19.8	14.9	11.9	9.9	7.9	5.9	1.4	0.91	0.68	0.54				
TP6505†	30	C	0.43	55	32	26	21	16.0	12.8	10.6	8.5	6.4	1.5	0.97	0.73	0.58				
TP8005	35	M	0.47	60	35	28	23	17.4	14.0	11.6	9.3	7.0	1.6	1.1	0.80	0.64				
TP11005	40	M	0.50	64	37	30	25	18.6	14.9	12.4	9.9	7.4	1.7	1.1	0.85	0.68				
TP6506†	30	C	0.56	72	42	33	28	21	16.6	13.9	11.1	8.3	1.9	1.3	0.95	0.76				
TP8006	35	C	0.61	78	45	36	30	23	18.1	15.1	12.1	9.1	2.1	1.4	1.0	0.83				
TP11006	40	C	0.67	86	50	40	33	25	19.9	16.6	13.3	9.9	2.3	1.5	1.1	0.91				
TP6508†	30	C	0.69	88	51	41	34	26	20	17.1	13.7	10.2	2.3	1.6	1.2	0.94				
TP8008	35	C	0.75	96	56	45	37	28	22	18.6	14.9	11.1	2.6	1.7	1.3	1.0				
TP11008	40	C	0.80	102	59	48	40	30	24	19.8	15.8	11.9	2.7	1.8	1.4	1.1				
TP6510†	30	C	0.89	114	66	53	44	33	26	22	17.6	13.2	3.0	2.0	1.5	1.2				
TP8010	35	C	0.98	125	73	58	49	36	29	24	19.4	14.6	3.3	2.2	1.7	1.3				
TP11010	40	C	1.07	137	81	65	54	41	33	27	20.7	15.6	3.6	2.4	1.8	1.4				
TP6515†	30		1.30	166	97	77	64	48	39	32	26	19.3	4.4	2.9	2.2	1.8				
TP8015	35		1.40	179	104	83	69	52	42	35	28	21	4.8	3.2	2.4	1.9				
TP11015	40		1.50	192	111	89	74	56	45	37	30	22	5.1	3.4	2.6	2.0				
TP6520†	30		1.68	215	125	100	83	62	50	42	33	25	5.7	3.8	2.9	2.3				
TP8020	35		1.84	236	137	109	91	68	55	46	36	27	6.3	4.2	3.1	2.5				
TP11020	40		2.00	256	149	119	99	74	59	50	40	30	6.8	4.5	3.4	2.7				
TP6530†	30		2.24	287	166	133	111	83	67	55	44	33	7.6	5.1	3.8	3.0				
TP8030	35		2.45	314	182	146	121	91	73	61	49	36	8.3	5.6	4.2	3.3				

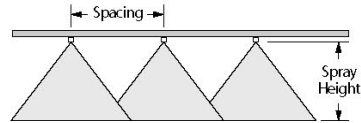

Optimum Spray Height

Tip Angle	Optimum Spray Height
65°	35"
80°	30"
110°	20"

Note: Always double check your application rates. Tabulations are based on spraying water at 70°F (21°C). †Available in all brass, stainless steel and hardened stainless steel only.

● Very Fine ● Fine ● Medium ● Coarse ● Very Coarse ● Extremely Coarse

BROADCAST NOZZLES

DG TeeJet® Drift Guard Flat Spray Tips

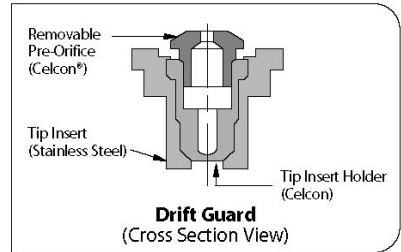

Note: Due to the pre-orifice design, this tip is not compatible with the 4193A check valve tip strainer.

Features:

- Pre-orifice design produces larger droplets and reduces the small drift-prone droplets, minimizing off-target spray contamination.
- Tapered edge flat spray pattern provides uniform coverage when adjacent nozzle patterns are overlapped in broadcast spraying.
- The color-coded pre-orifice is removable for any necessary cleaning operations.
- Available in both 80° and 110° spray angles with a durable stainless steel orifice.
- Automatic spray alignment with Quick TeeJet® cap and gasket.

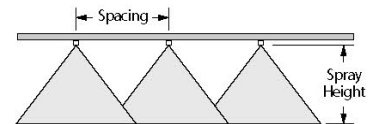

PSI	DROP SIZE		CAPACITY ONE NOZZLE IN GPM	CAPACITY ONE NOZZLE IN OZ./MIN.	20°														
					GPA										GALLONS PER 1000 SQ. FT.				
					4 MPH	5 MPH	6 MPH	8 MPH	10 MPH	12 MPH	15 MPH	20 MPH	2 MPH	3 MPH	4 MPH	5 MPH			
30	M	M	0.13	17	9.7	7.7	6.4	4.8	3.9	3.2	2.6	1.9	0.44	0.29	0.22	0.18			
	M	M	0.14	18	10.4	8.3	6.9	5.2	4.2	3.5	2.8	2.1	0.48	0.32	0.24	0.19			
	M	F	0.15	19	11.1	8.9	7.4	5.6	4.5	3.7	3.0	2.2	0.51	0.34	0.26	0.20			
	M	F	0.17	22	12.6	10.1	8.4	6.3	5.0	4.2	3.4	2.5	0.58	0.39	0.29	0.23			
40	M	F	0.18	23	13.4	10.7	8.9	6.7	5.3	4.5	3.6	2.7	0.61	0.41	0.31	0.24			
	M	M	0.17	22	12.6	10.1	8.4	6.3	5.0	4.2	3.4	2.5	0.58	0.39	0.29	0.23			
	M	M	0.19	24	14.1	11.3	9.4	7.1	5.6	4.7	3.8	2.8	0.65	0.43	0.32	0.26			
	M	M	0.20	26	14.9	11.9	9.9	7.4	5.9	5.0	4.0	3.0	0.68	0.45	0.34	0.27			
50	M	M	0.22	28	16.3	13.1	10.9	8.2	6.5	5.4	4.4	3.3	0.75	0.50	0.37	0.30			
	M	M	0.24	31	17.8	14.3	11.9	8.9	7.1	5.9	4.8	3.6	0.82	0.54	0.41	0.33			
	C	C	0.26	33	19.3	15.4	12.9	9.7	7.7	6.4	5.1	3.9	0.88	0.59	0.44	0.35			
	M	M	0.28	36	21	16.6	13.9	10.4	8.3	6.9	5.5	4.2	0.95	0.63	0.48	0.38			
60	M	M	0.30	38	22	17.8	14.9	11.1	8.9	7.4	5.9	4.5	1.0	0.68	0.51	0.41			
	M	M	0.34	44	25	20	16.8	12.6	10.1	8.4	6.7	5.0	1.2	0.77	0.58	0.46			
	M	M	0.37	47	27	22	18.3	13.7	11.0	9.2	7.3	5.5	1.3	0.84	0.63	0.50			
	C	C	0.35	45	26	21	17.3	13.0	10.4	8.7	6.9	5.2	1.2	0.79	0.60	0.48			
35	C	C	0.37	47	27	22	18.3	13.7	11.0	9.2	7.3	5.5	1.3	0.84	0.63	0.50			
	C	M	0.40	51	30	24	19.8	14.9	11.9	9.9	7.9	5.9	1.4	0.91	0.68	0.54			
	M	M	0.45	58	33	27	22	16.7	13.4	11.1	8.9	6.7	1.5	1.0	0.77	0.61			
	M	M	0.49	63	36	29	24	18.2	14.6	12.1	9.7	7.3	1.7	1.1	0.83	0.67			
40	C	C	0.43	55	32	26	21	16.0	12.8	10.6	8.5	6.4	1.5	0.97	0.73	0.58			
	C	C	0.47	60	35	28	23	17.4	14.0	11.6	9.3	7.0	1.6	1.1	0.80	0.64			
	C	C	0.50	64	37	30	25	18.6	14.9	12.4	9.9	7.4	1.7	1.1	0.85	0.68			
	M	M	0.56	72	42	33	28	21	16.6	13.9	11.1	8.3	1.9	1.3	0.95	0.76			
50	M	M	0.61	78	45	36	30	23	18.1	15.1	12.1	9.1	2.1	1.4	1.0	0.83			

Note: Always double check your application rates. Tabulations are based on spraying water at 70°F (21°C). † Available in VisiFlo stainless steel only.



Optimum Spray Height

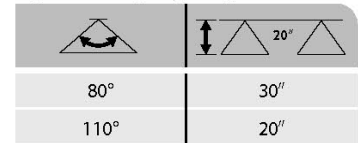

BROADCAST NOZZLES

Turbo FloodJet® Wide Angle Flat Spray Tips



Features:

- Excellent spray distribution for uniform coverage along the boom.
- Nozzle design incorporates a pre-orifice to produce larger droplets for less drift.
- Large, round orifice reduces clogging.
- Stainless steel or polymer with VisiFlo® color-coding band for easy size identification.
- Can be used with Quick TeeJet® cap and gasket for automatic alignment.

QCT Cam-Loc Adapter

- Provides easy changeover from high capacity to lower capacity nozzles.
- Adapter fits standard 3/4" quick connect Cam-Loc holders.
- Corrosion-resistant stainless steel and polypropylene construction.
- Rated up to 100 PSI (7 bar).
- Use QJT-NYB to retrofit to Quick TeeJet.



CONTACT PRODUCT	SYSTEMIC PRODUCT	DRIFT MANAGEMENT
—	VERY GOOD	EXCELLENT

PSI	DROP SIZE	CAPACITY ONE NOZZLE IN GPA	CAPACITY ONE NOZZLE IN OZ./MIN.	40°								20°				
				GPA								GALLONS PER 1000 SQ. FT.				
				4 MPH	5 MPH	6 MPH	8 MPH	10 MPH	12 MPH	15 MPH	20 MPH	2 MPH	3 MPH	4 MPH	5 MPH	
TF-†2 (50)	10	XC	0.20	26	7.4	5.9	5.0	3.7	3.0	2.5	2.0	1.5	0.68	0.45	0.34	0.27
	20	XC	0.28	36	10.4	8.3	6.9	5.2	4.2	3.5	2.8	2.1	0.95	0.63	0.48	0.38
	30	XC	0.35	45	13.0	10.4	8.7	6.5	5.2	4.3	3.5	2.6	1.2	0.79	0.60	0.48
	40	XC	0.40	51	14.9	11.9	9.9	7.4	5.9	5.0	4.0	3.0	1.4	0.91	0.68	0.54
TF-†2.5 (50)	10	XC	0.25	32	9.3	7.4	6.2	4.6	3.7	3.1	2.5	1.9	0.85	0.57	0.43	0.34
	20	XC	0.35	45	13.0	10.4	8.7	6.5	5.2	4.3	3.5	2.6	1.2	0.79	0.60	0.48
	30	XC	0.43	55	16.0	12.8	10.6	8.0	6.4	5.3	4.3	3.2	1.5	0.97	0.73	0.58
	40	XC	0.50	64	18.6	14.9	12.4	9.3	7.4	6.2	5.0	3.7	1.7	1.1	0.85	0.68
TF-†3 (50)	10	XC	0.30	38	11.1	8.9	7.4	5.6	4.5	3.7	3.0	2.2	1.0	0.68	0.51	0.41
	20	XC	0.42	54	15.6	12.5	10.4	7.8	6.2	5.2	4.2	3.1	1.4	0.95	0.71	0.57
	30	XC	0.52	67	19.3	15.4	12.9	9.7	7.7	6.4	5.1	3.9	1.8	1.2	0.88	0.71
	40	XC	0.60	77	22	17.8	14.9	11.1	8.9	7.4	5.9	4.5	2.0	1.4	1.0	0.82
TF-†4 (50)	10	XC	0.40	51	14.9	11.9	9.9	7.4	5.9	5.0	4.0	3.0	1.4	0.91	0.68	0.54
	20	XC	0.57	73	21	16.9	14.1	10.6	8.5	7.1	5.6	4.2	1.9	1.3	0.97	0.78
	30	XC	0.69	88	26	20	17.1	12.8	10.2	8.5	6.8	5.1	2.3	1.6	1.2	0.94
	40	XC	0.80	102	30	24	19.8	14.9	11.9	9.9	7.9	5.9	2.7	1.8	1.4	1.1
TF-†5	10	XC	0.50	64	18.6	14.9	12.4	9.3	7.4	6.2	5.0	3.7	1.7	1.1	0.85	0.68
	20	XC	0.71	91	26	21	17.6	13.2	10.5	8.8	7.0	5.3	2.4	1.6	1.2	0.97
	30	XC	0.87	111	32	26	22	16.1	12.9	10.8	8.6	6.5	3.0	2.0	1.5	1.2
	40	XC	1.00	128	37	30	25	18.6	14.9	12.4	9.9	7.4	3.4	2.3	1.7	1.4
TF-†7.5	10	XC	0.75	96	28	22	18.6	13.9	11.1	9.3	7.4	5.6	2.6	1.7	1.3	1.0
	20	XC	1.06	136	39	31	26	19.7	15.7	13.1	10.5	7.9	3.6	2.4	1.8	1.4
	30	XC	1.30	166	48	39	32	24	19.3	16.1	12.9	9.7	4.4	2.9	2.2	1.8
	40	XC	1.50	192	56	45	37	28	22	18.6	14.9	11.1	5.1	3.4	2.6	2.0
TF-†10	10	XC	1.00	128	37	30	25	18.6	14.9	12.4	9.9	7.4	3.4	2.3	1.7	1.4
	20	XC	1.41	180	52	42	35	26	21	17.4	14.0	10.5	4.8	3.2	2.4	1.9
	30	XC	1.73	221	64	51	43	32	26	21	17.1	12.8	5.9	3.9	2.9	2.4
	40	XC	2.00	256	74	59	50	37	30	25	19.8	14.9	6.8	4.5	3.4	2.7

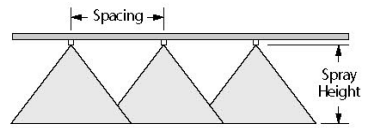

Optimum Spray Height

Spacing	Spray Height
20"	24"*
30"	30"*
40"	39"*

*Wide angle spray nozzle height is influenced by nozzle orientation. The critical factor is to achieve a minimum 30% overlap.

Note: Always double check your application rates. Tabulations are based on spraying water at 70°F (21°C). †Specify material.



TeeJet® Disc-Core Type Cone Spray Tips



For spraying pesticides at higher pressures and flow rates. Especially suitable for wettable powders and other abrasive chemicals. Larger capacity nozzles are also used in air blast sprayers.

- Produce smaller droplets for thorough coverage with contact pesticides and foliar applications.
- Maximum spray pressure to 300 PSI (20 bar).

Typical Assembly with Ceramic Disc and Core



Orifice Discs

Available in a variety of sizes and materials. Ceramic for increased wear life, hardened stainless steel, stainless steel and polymer.

Ceramic Sizes Available:

DCER-2 through DCER-8, DCER-10.



Cores

Standard cores are made of brass. Also available in ceramic, hardened stainless steel, aluminum and Nylon. All cores, with the exception of ceramic, are made with rear "nibs". Be sure core is always placed with the nib facing the nozzle body.

Ceramic Sizes Available:

DC13-CER, DC23-CER, DC25-CER, DC31-CER, DC33-CER, DC35-CER, DC45-CER, DC46-CER, DC56-CER.



Orifice Disc	Core	PSI	CAPACITY ONE NOZZLE IN GPM	CAPACITY ONE NOZZLE IN OZ./MIN.	GPA 20°							
					4 MPH	5 MPH	6 MPH	8 MPH	10 MPH	12 MPH	15 MPH	20 MPH
D2	DC13	40	0.08	10	5.9	4.8	4.0	3.0	2.4	2.0	1.6	1.2
		60	0.10	13	7.4	5.9	5.0	3.7	3.0	2.5	2.0	1.5
		80	0.11	14	8.2	6.5	5.4	4.1	3.3	2.7	2.2	1.6
		100	0.12	15	8.9	7.1	5.9	4.5	3.6	3.0	2.4	1.8
		150	0.14	18	10.4	8.3	6.9	5.2	4.2	3.5	2.8	2.1
D3	DC13	40	0.09	12	6.7	5.3	4.5	3.3	2.7	2.2	1.8	1.3
		60	0.11	14	8.2	6.5	5.4	4.1	3.3	2.7	2.2	1.6
		80	0.12	15	8.9	7.1	5.9	4.5	3.6	3.0	2.4	1.8
		100	0.13	17	9.7	7.7	6.4	4.8	3.9	3.2	2.6	1.9
		150	0.16	20	11.9	9.5	7.9	5.9	4.8	4.0	3.2	2.4
D4	DC13	40	0.12	15	8.9	7.1	5.9	4.5	3.6	3.0	2.4	1.8
		60	0.14	18	10.4	8.3	6.9	5.2	4.2	3.5	2.8	2.1
		80	0.16	20	11.9	9.5	7.9	5.9	4.8	4.0	3.2	2.4
		100	0.17	22	12.6	10.1	8.4	6.3	5.0	4.2	3.4	2.5
		150	0.20	26	14.9	11.9	9.9	7.4	5.9	5.0	4.0	3.0
D2	DC23	40	0.10	13	7.4	5.9	5.0	3.7	3.0	2.5	2.0	1.5
		60	0.13	17	9.7	7.7	6.4	4.8	3.9	3.2	2.6	1.9
		80	0.14	18	10.4	8.3	6.9	5.2	4.2	3.5	2.8	2.1
		100	0.16	20	11.9	9.5	7.9	5.9	4.8	4.0	3.2	2.4
		150	0.19	24	14.1	11.3	9.4	7.1	5.6	4.7	3.8	2.8
D3	DC23	40	0.12	15	8.9	7.1	5.9	4.5	3.6	3.0	2.4	1.8
		60	0.14	18	10.4	8.3	6.9	5.2	4.2	3.5	2.8	2.1
		80	0.16	20	11.9	9.5	7.9	5.9	4.8	4.0	3.2	2.4
		100	0.18	23	13.4	10.7	8.9	6.7	5.3	4.5	3.6	2.7
		150	0.21	27	15.6	12.5	10.4	7.8	6.2	5.2	4.2	3.1
D4	DC23	40	0.15	19	11.1	8.9	7.4	5.6	4.5	3.7	3.0	2.2
		60	0.19	24	14.1	11.3	9.4	7.1	5.6	4.7	3.8	2.8
		80	0.21	27	15.6	12.5	10.4	7.8	6.2	5.2	4.2	3.1
		100	0.23	29	17.1	13.7	11.4	8.5	6.8	5.7	4.6	3.4
		150	0.28	36	21	16.6	13.9	10.4	8.3	6.9	5.5	4.2
D5	DC23	40	0.18	23	13.4	10.7	8.9	6.7	5.3	4.5	3.6	2.7
		60	0.22	28	16.3	13.1	10.9	8.2	6.5	5.4	4.4	3.3
		80	0.25	32	18.6	14.9	12.4	9.3	7.4	6.2	5.0	3.7
		100	0.28	36	21	16.6	13.9	10.4	8.3	6.9	5.5	4.2
		150	0.34	44	25	20	16.8	12.6	10.1	8.4	6.7	5.0
D2	DC25	40	0.16	20	11.9	9.5	7.9	5.9	4.8	4.0	3.2	2.4
		60	0.19	24	14.1	11.3	9.4	7.1	5.6	4.7	3.8	2.8
		80	0.22	28	16.3	13.1	10.9	8.2	6.5	5.4	4.4	3.3
		100	0.25	32	18.6	14.9	12.4	9.3	7.4	6.2	5.0	3.7
		150	0.29	37	22	17.2	14.4	10.8	8.6	7.2	5.7	4.3
D3	DC25	40	0.19	24	14.1	11.3	9.4	7.1	5.6	4.7	3.8	2.8
		60	0.23	29	17.1	13.7	11.4	8.5	6.8	5.7	4.6	3.4
		80	0.26	33	19.3	15.4	12.9	9.7	7.7	6.4	5.1	3.9
		100	0.29	37	22	17.2	14.4	10.8	8.6	7.2	5.7	4.3
		150	0.35	45	26	21	17.3	13.0	10.4	8.7	6.9	5.2
D4	DC25	40	0.29	37	22	17.2	14.4	10.8	8.6	7.2	5.7	4.3
		60	0.35	45	26	21	17.3	13.0	10.4	8.7	6.9	5.2
		80	0.40	51	30	24	19.8	14.9	11.9	9.9	7.9	5.9
		100	0.45	58	33	27	22	16.7	13.4	11.1	8.9	6.7
		150	0.54	69	40	32	27	20	16.0	13.4	10.7	8.0
D5	DC25	40	0.35	45	26	21	17.3	13.0	10.4	8.7	6.9	5.2
		60	0.42	54	31	25	21	15.6	12.5	10.4	8.3	6.2
		80	0.48	61	36	29	24	17.8	14.3	11.9	9.5	7.1
		100	0.54	69	40	32	27	20	16.0	13.4	10.7	8.0
		150	0.65	83	48	39	32	24	19.3	16.1	12.9	9.7
D2	DC45	40	0.20	26	14.9	11.9	9.9	7.4	5.9	5.0	4.0	3.0
		60	0.25	32	18.6	14.9	12.4	9.3	7.4	6.2	5.0	3.7
		80	0.28	36	21	16.6	13.9	10.4	8.3	6.9	5.5	4.2
		100	0.32	41	24	19.0	15.8	11.9	9.5	7.9	6.3	4.8
		150	0.38	49	28	23	18.8	14.1	11.3	9.4	7.5	5.6
D3	DC45	40	0.23	29	17.1	13.7	11.4	8.5	6.8	5.7	4.6	3.4
		60	0.28	36	21	16.6	13.9	10.4	8.3	6.9	5.5	4.2
		80	0.33	42	25	19.6	16.3	12.3	9.8	8.2	6.5	4.9
		100	0.36	46	27	21	17.8	13.4	10.7	8.9	7.1	5.3
		150	0.44	56	33	26	22	16.3	13.1	10.9	8.7	6.5
D4	DC45	40	0.36	46	27	21	17.8	13.4	10.7	8.9	7.1	5.3
		60	0.43	55	32	26	21	16.0	12.8	10.6	8.5	6.4
		80	0.50	64	37	30	25	18.6	14.9	12.4	9.9	7.4
		100	0.56	72	42	33	28	21	16.6	13.9	11.1	8.3
		150	0.68	87	50	40	34	25	20	16.8	13.5	10.1
D5	DC45	40	0.45	58	33	27	22	16.7	13.4	11.1	8.9	6.7
		60	0.55	70	41	33	27	20	16.3	13.6	10.9	8.2
		80	0.64	82	48	38	32	24	19.0	15.8	12.7	9.5
		100	0.71	91	53	42	35	26	21	17.6	14.1	10.5
		150	0.86	110	64	51	43	32	26	21	17.0	12.8

How to order:

To order orifice disc only, specify disc number and material.

- Examples:
- DCER-2 - Ceramic
 - D2 - Hardened Stainless Steel
 - DE-2 - Stainless Steel
 - DVP-2 - Polymer

To order core only, specify core number and material.

- Examples:
- DC13-CER - Ceramic
 - DC13-HSS - Hardened Stainless Steel
 - DC13-AL - Aluminum
 - DC13 - Brass
 - DC13-NY - Nylon
 - CP18999-EPR Seal Gasket

STRAINER NOTE: For nozzles using orifice disc numbers 1, 1.5 and 2; or core numbers 31 and 33, slotted strainer number 4514-20 equivalent to 25 mesh screen size is required. For all other larger capacity discs and cores, slotted strainer number 4514-32 equivalent to 16 mesh screen size is required.

Note: Always double check your application rates. Tabulations are based on spraying water at 70°F (21°C).

ConeJet® VisiFlo® Hollow Cone Spray Tips

Typical Applications:

Excellent: Post-Emerge Contact Herbicides, Fungicides and Insecticides — To assure finely atomized spray droplets reach target areas.

Good: For use with defoliant and foliar fertilizers at pressures 40 PSI (3 bar) and above.

Features:

- VisiFlo color-coded version consists of stainless steel or ceramic orifice in polypropylene body. Maximum operating pressure 300 PSI (20 bar). Spray angle is 80° at 100 PSI (7 bar).
- Finely atomized spray pattern provides thorough coverage.
- TX-VS1 and TX-VS2 available in VisiFlo color-coded stainless steel only.



Nozzle Model	PSI	CAPACITY ONE NOZZLE IN GPM	CAPACITY ONE NOZZLE IN OZ./MIN.	GPA 20°							
				4 MPH	5 MPH	6 MPH	8 MPH	10 MPH	12 MPH	15 MPH	20 MPH
TX-1	40	0.017	2.2	1.3	1.0	0.84	0.63	0.50	0.42	0.34	0.25
TX-†1	60	0.020	2.6	1.5	1.2	0.99	0.74	0.59	0.50	0.40	0.30
(100)	80	0.022	2.8	1.6	1.3	1.1	0.82	0.65	0.54	0.44	0.33
	100	0.024	3.1	1.8	1.4	1.2	0.89	0.71	0.59	0.48	0.36
	125	0.027	3.5	2.0	1.6	1.3	1.0	0.80	0.67	0.53	0.40
TX-2	40	0.033	4.2	2.5	2.0	1.6	1.2	0.98	0.82	0.65	0.49
TX-†2	60	0.040	5.1	3.0	2.4	2.0	1.5	1.2	0.99	0.79	0.59
(100)	80	0.045	5.8	3.3	2.7	2.2	1.7	1.3	1.1	0.89	0.67
	100	0.050	6.4	3.7	3.0	2.5	1.9	1.5	1.2	0.99	0.74
	125	0.055	7.0	4.1	3.3	2.7	2.0	1.6	1.4	1.1	0.82
TX-3	40	0.050	6.4	3.7	3.0	2.5	1.9	1.5	1.2	0.99	0.74
TX-†3	60	0.060	7.7	4.5	3.6	3.0	2.2	1.8	1.5	1.2	0.89
(100)	80	0.068	8.7	5.0	4.0	3.4	2.5	2.0	1.7	1.3	1.0
	100	0.075	9.6	5.6	4.5	3.7	2.8	2.2	1.9	1.5	1.1
	125	0.082	10	6.1	4.9	4.1	3.0	2.4	2.0	1.6	1.2
TX-4	40	0.067	8.6	5.0	4.0	3.3	2.5	2.0	1.7	1.3	1.0
TX-†4	60	0.080	10	5.9	4.8	4.0	3.0	2.4	2.0	1.6	1.2
(50)	80	0.091	12	6.8	5.4	4.5	3.4	2.7	2.3	1.8	1.4
	100	0.10	13	7.4	5.9	5.0	3.7	3.0	2.5	2.0	1.5
	125	0.11	14	8.2	6.5	5.4	4.1	3.3	2.7	2.2	1.6
TX-6	40	0.10	13	7.4	5.9	5.0	3.7	3.0	2.5	2.0	1.5
TX-†6	60	0.12	15	8.9	7.1	5.9	4.5	3.6	3.0	2.4	1.8
(50)	80	0.14	18	10.4	8.3	6.9	5.2	4.2	3.5	2.8	2.1
	100	0.15	19	11.1	8.9	7.4	5.6	4.5	3.7	3.0	2.2
	125	0.17	22	12.6	10.1	8.4	6.3	5.0	4.2	3.4	2.5
TX-8	40	0.13	17	9.7	7.7	6.4	4.8	3.9	3.2	2.6	1.9
TX-†8	60	0.16	20	11.9	9.5	7.9	5.9	4.8	4.0	3.2	2.4
(50)	80	0.19	24	14.1	11.3	9.4	7.1	5.6	4.7	3.8	2.8
	100	0.21	27	15.6	12.5	10.4	7.8	6.2	5.2	4.2	3.1
	125	0.23	29	17.1	13.7	11.4	8.5	6.8	5.7	4.6	3.4
TX-10	40	0.17	22	12.6	10.1	8.4	6.3	5.0	4.2	3.4	2.5
TX-†10	60	0.20	26	14.9	11.9	9.9	7.4	5.9	5.0	4.0	3.0
(50)	80	0.23	29	17.1	13.7	11.4	8.5	6.8	5.7	4.6	3.4
	100	0.26	33	19.3	15.4	12.9	9.7	7.7	6.4	5.1	3.9
	125	0.29	37	22	17.2	14.4	10.8	8.6	7.2	5.7	4.3
TX-12	40	0.20	26	14.9	11.9	9.9	7.4	5.9	5.0	4.0	3.0
TX-†12	60	0.24	31	17.8	14.3	11.9	8.9	7.1	5.9	4.8	3.6
(50)	80	0.28	36	21	16.6	13.9	10.4	8.3	6.9	5.5	4.2
	100	0.31	40	23	18.4	15.3	11.5	9.2	7.7	6.1	4.6
	125	0.34	44	25	20	16.8	12.6	10.1	8.4	6.7	5.0
TX-18	40	0.30	38	22	17.8	14.9	11.1	8.9	7.4	5.9	4.5
TX-†18	60	0.37	47	27	22	18.3	13.7	11.0	9.2	7.3	5.5
(50)	80	0.42	54	31	25	21	15.6	12.5	10.4	8.3	6.2
	100	0.47	60	35	28	23	17.4	14.0	11.6	9.3	7.0
	125	0.53	68	39	31	26	19.7	15.7	13.1	10.5	7.9
TX-26	40	0.43	55	32	26	21	16.0	12.8	10.6	8.5	6.4
TX-†26	60	0.53	68	39	31	26	19.7	15.7	13.1	10.5	7.9
(50)	80	0.61	78	45	36	30	23	18.1	15.1	12.1	9.1
	100	0.68	87	50	40	34	25	20	16.8	13.5	10.1
	125	0.76	97	56	45	38	28	23	18.8	15.0	11.3

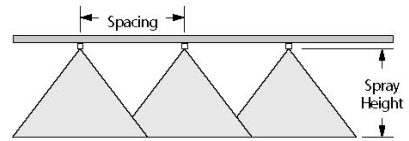

Optimum Spray Height

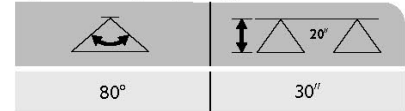

Note: Always double check your application rates. Tabulations are based on spraying water at 70°F (21°C).

†Specify material.

BROADCAST NOZZLES



XP BoomJet Boomless Flat Spray Nozzles

Typical Applications:

- Boomless field spray applications.
- Roadside and right-of-way applications.
- End row spraying.
- Orchard spraying.
- De-icing applications.
- Forestry.

Features:

- Unique orifice geometry produces a wide spray pattern while maintaining superior distribution across entire width.
- Pre-orifice design minimizes drift.
- Extra wide spray pattern—up to 18.5 feet (5.5 meters)—using a single nozzle.
- Removable polymer pre-orifice.
- Acetal or stainless steel construction for excellent chemical resistance.
- Recommended spray pressure range: 20–60 PSI (1.5–4 bar).

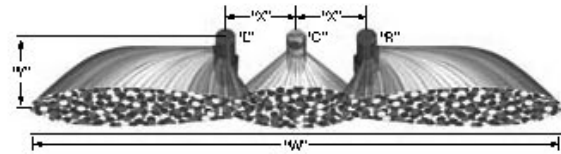

NOZZLE MODEL	CENTER NOZZLE "C"	PSI	DROP SIZE	CAPACITY THREE NOZZLES IN GPM	SPRAY WIDTH "W" (FEET)		HEIGHT = 24"										HEIGHT = 36"									
					24" HEIGHT	36" HEIGHT	GPA FOR THREE NOZZLES					GALLONS PER 1000 SQ. FT.					GPA FOR THREE NOZZLES					GALLONS PER 1000 SQ. FT.				
					4 MPH	6 MPH	8 MPH	10 MPH	15 MPH	20 MPH	2 MPH	3 MPH	4 MPH	5 MPH	4 MPH	6 MPH	8 MPH	10 MPH	15 MPH	20 MPH	2 MPH	3 MPH	4 MPH	5 MPH		
(B) 1/4" XP 10R (B) 1/4" XP 10L	1/4TTJ08	30	XC	2.43	23.3	25.3	12.9	8.6	6.5	5.2	3.4	2.6	0.99	0.39	0.30	0.24	11.9	7.9	5.9	4.8	3.2	2.4	0.54	0.36	0.27	0.22
		40	XC	2.80	25.3	28.3	13.7	9.1	6.8	5.5	3.7	2.7	0.63	0.42	0.31	0.25	12.2	8.2	6.1	4.9	3.3	2.4	0.56	0.37	0.28	0.23
		50	XC	3.13	28.3	30.3	13.7	9.1	6.8	5.5	3.6	2.7	0.63	0.42	0.31	0.25	12.8	8.5	6.4	5.1	3.4	2.6	0.59	0.39	0.29	0.23
		60	XC	3.42	29.3	32.3	14.4	9.6	7.2	5.8	3.9	2.9	0.66	0.44	0.33	0.26	13.1	8.7	6.6	5.2	3.5	2.6	0.60	0.40	0.30	0.24
(B) 1/4" XP 20R (B) 1/4" XP 20L	1/4TTJ08	30	XC	4.19	26.3	27.3	19.7	13.1	9.9	7.9	5.3	3.9	0.90	0.60	0.45	0.36	19.0	12.7	9.5	7.6	5.1	3.8	0.87	0.58	0.43	0.35
		40	XC	4.80	30.3	31.3	19.6	13.1	9.8	7.8	5.2	3.9	0.90	0.60	0.45	0.36	19.0	12.7	9.5	7.6	5.1	3.8	0.87	0.58	0.43	0.35
		50	XC	5.39	32.3	33.3	21	13.8	10.2	8.3	5.5	4.1	0.95	0.62	0.47	0.38	20	13.4	10.0	8.0	5.3	4.0	0.92	0.61	0.46	0.37
		60	XC	5.98	33.3	35.3	22	14.8	11.1	8.9	5.9	4.4	1.0	0.68	0.51	0.41	21	14.0	10.5	8.4	5.6	4.2	0.96	0.64	0.48	0.38
(B) 1/4" XP 25R (B) 1/4" XP 25L	1/4TTJ10	30	XC	5.13	27.3	30.3	23	15.5	11.6	9.3	6.2	4.7	1.1	0.71	0.53	0.43	21	14.0	10.5	8.4	5.6	4.2	0.96	0.64	0.48	0.38
		40	XC	6.00	30.3	32.3	25	16.3	12.3	9.8	6.5	4.9	1.1	0.75	0.56	0.45	23	15.3	11.5	9.2	6.1	4.6	1.1	0.70	0.53	0.42
		50	XC	6.62	32.3	33.3	25	16.9	12.7	10.1	6.8	5.1	1.2	0.77	0.58	0.46	25	16.4	12.3	9.8	6.6	4.9	1.1	0.75	0.56	0.45
		60	XC	7.22	33.3	35.3	27	17.9	13.4	10.7	7.2	5.4	1.2	0.82	0.61	0.49	25	16.9	12.7	10.1	6.7	5.1	1.2	0.77	0.58	0.46
(B) 1/2" XP 40R (B) 1/2" XP 40L	1/4TTJ15	30	XC	8.36	29.3	32.3	35	24	17.7	14.1	9.4	7.1	1.6	1.1	0.81	0.65	32	21	16.0	12.8	8.5	6.4	1.5	0.98	0.73	0.59
		40	XC	9.50	31.3	34.3	38	25	18.8	15.0	10.0	7.5	1.7	1.1	0.86	0.69	34	23	17.1	13.7	9.1	6.9	1.6	1.0	0.78	0.62
		50	XC	10.8	33.3	35.3	40	27	20	16.1	10.7	8.0	1.8	1.2	0.92	0.74	38	25	18.9	15.1	10.1	7.6	1.7	1.2	0.87	0.69
		60	XC	11.8	35.3	38.3	41	28	21	16.5	11.0	8.3	1.9	1.3	0.95	0.76	38	25	19.1	15.3	10.2	7.6	1.7	1.2	0.87	0.70

NOZZLE MODEL	CENTER NOZZLE "C"	PSI	DROP SIZE	CAPACITY THREE NOZZLES IN GPM	SPRAY WIDTH "W" (FEET)		HEIGHT = 24"										HEIGHT = 36"									
					24" HEIGHT	36" HEIGHT	GPA FOR THREE NOZZLES					GALLONS PER 1000 SQ. FT.					GPA FOR THREE NOZZLES					GALLONS PER 1000 SQ. FT.				
					4 MPH	6 MPH	8 MPH	10 MPH	15 MPH	20 MPH	2 MPH	3 MPH	4 MPH	5 MPH	4 MPH	6 MPH	8 MPH	10 MPH	15 MPH	20 MPH	2 MPH	3 MPH	4 MPH	5 MPH		
(B) 1/4" XP 10R (B) 1/4" XP 10L (50)	1/4TTJ08 (50)	30	XC	2.26	25.0	27.0	11.2	7.5	5.6	4.5	3.0	2.2	0.51	0.34	0.26	0.20	10.4	6.9	5.2	4.1	2.8	2.1	0.47	0.32	0.24	0.19
		40	XC	2.60	27.0	30.0	11.9	7.9	6.0	4.8	3.2	2.4	0.55	0.36	0.27	0.22	10.7	7.2	5.4	4.3	2.9	2.1	0.49	0.33	0.25	0.20
		50	XC	2.91	30.0	32.0	12.0	8.0	6.0	4.8	3.2	2.4	0.55	0.37	0.27	0.22	11.3	7.5	5.6	4.5	3.0	2.3	0.52	0.34	0.26	0.21
		60	XC	3.17	31.0	34.0	12.7	8.4	6.3	5.1	3.4	2.5	0.58	0.39	0.29	0.23	11.5	7.7	5.8	4.6	3.1	2.3	0.53	0.35	0.26	0.21
(B) 1/4" XP 20R (B) 1/4" XP 20L (50)	1/4TTJ08 (50)	30	XC	4.02	28.0	29.0	17.8	11.8	8.9	7.1	4.7	3.6	0.81	0.54	0.41	0.33	17.2	11.4	8.6	6.9	4.6	3.4	0.79	0.52	0.39	0.31
		40	XC	4.60	32.0	33.0	17.8	11.9	8.9	7.1	4.7	3.6	0.81	0.54	0.41	0.33	17.3	11.5	8.6	6.9	4.6	3.5	0.79	0.53	0.39	0.32
		50	XC	5.17	34.0	35.0	18.8	12.5	9.4	7.5	5.0	3.8	0.86	0.57	0.43	0.34	18.3	12.2	9.1	7.3	4.9	3.7	0.84	0.56	0.42	0.33
		60	XC	5.73	35.0	37.0	20	13.5	10.1	8.1	5.4	4.1	0.93	0.62	0.46	0.37	19.2	12.8	9.6	7.7	5.1	3.8	0.88	0.59	0.44	0.35
(B) 1/4" XP 25R (B) 1/4" XP 25L (50)	1/4TTJ08 (50)	30	XC	4.95	29.0	32.0	21	14.1	10.6	8.4	5.6	4.2	0.97	0.64	0.48	0.39	19.1	12.8	9.6	7.7	5.1	3.8	0.88	0.58	0.44	0.35
		40	XC	5.80	32.0	34.0	22	15.0	11.2	9.0	6.0	4.5	1.0	0.68	0.51	0.41	21	14.1	10.6	8.4	5.6	4.2	0.97	0.64	0.48	0.39
		50	XC	6.39	34.0	35.0	23	15.5	11.6	9.3	6.2	4.7	1.1	0.71	0.53	0.43	23	15.1	11.3	9.0	6.0	4.5	1.0	0.69	0.52	0.41
		60	XC	6.98	35.0	37.0	25	16.5	12.3	9.9	6.6	4.9	1.1	0.75	0.57	0.45	23	15.6	11.7	9.3	6.2	4.7	1.1	0.71	0.53	0.43
(B) 1/2" XP 40R (B) 1/2" XP 40L (50)	1/4TTJ10 (50)	30	XC	7.93	31.0	34.0	32	21	15.8	12.7	8.4	6.3	1.4	0.97	0.72	0.58	29	19.2	14.4	11.5	7.7	5.8	1.3	0.88	0.66	0.53
		40	XC	9.00	33.0	36.0	34	23	16.9	13.5	9.0	6.8	1.5	1.0	0.77	0.62	31	21	15.5	12.4	8.3	6.2	1.4	0.94	0.71	0.57
		50	XC	10.2	35.0	37.0	36	24	18.0	14.4	9.6	7.2	1.7	1.1	0.83	0.66	34	23	17.1	13.6	9.1	6.8	1.6	1.0	0.78	0.62
		60	XC	11.2	37.0	40.0	37	25	18.7	15.0	10.0	7.5	1.7	1.1	0.86	0.69	35	23	17.3	13.9	9.2	6.9	1.6	1.1	0.79	0.63
(B) 1/2" XP 80R (B) 1/2" XP 80L (50)	1/4TTJ15 (50)	30	XC	15.0	35.0	38.0	53	35	27	21	14.1	10.6	2.4	1.6	1.2	0.97	49	33	24	19.5	13.0	9.8	2.2	1.5	1.1	0.89
		40	XC	17.5	37.0	40.0	59	39	29	23	15.6	11.7	2.7	1.8	1.3	1.1	54	36	27	22	14.4	10.8	2.5	1.7	1.2	0.99
		50	XC	19.1	38.0	41.0	62	41	31	25	16.6	12.4	2.8	1.9	1.4	1.1	58	38	29	23	15.4	11.5	2.6	1.8	1.3	1.1
		60	XC	21.0	40.0	42.0	65	43	32	26	17.3	13.0	3.0	2.0	1.5	1.2	62	41	31	25	16.5	12.4	2.8	1.9	1.4	1.1

Note: Always double check your application rates.
Tabulations are based on spraying water at 70°F (21°C).



BOOMLESS NOZZLES

XP BoomJet™ Boomless Flat Spray Nozzles

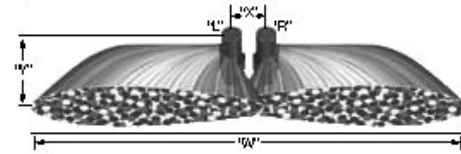

Nozzle Model	PSI	DROPSIZE	CAPACITY TWO NOZZLES IN GPM	SPRAY WIDTH "W" (FEET)		NOZZLE SPACING "X" = 0'-3"										NOZZLE SPACING "X" = 0'-3"										
				24" HEIGHT	36" HEIGHT	GPA FOR TWO NOZZLES					GALLONS PER 1000 SQ. FT.					GPA FOR TWO NOZZLES					GALLONS PER 1000 SQ. FT.					
						4 MPH	6 MPH	8 MPH	10 MPH	15 MPH	20 MPH	2 MPH	3 MPH	4 MPH	5 MPH	4 MPH	6 MPH	8 MPH	10 MPH	15 MPH	20 MPH	2 MPH	3 MPH	4 MPH	5 MPH	
				(B)1/4XP 10 R (B)1/4CP 10 L	20 30 40 50 60	XC XC XC XC XC	1.42 1.74 2.00 2.24 2.44	17.0 20.0 22.0 25.0 27.0	20.0 22.0 25.0 27.0 29.0	10.3 10.8 11.3 11.1 11.6	6.9 7.2 7.5 7.4 7.7	5.2 5.4 5.6 5.5 5.8	4.1 4.3 4.5 4.4 4.6	2.8 2.9 3.0 3.0 3.1	2.1 2.2 2.3 2.2 2.3	0.47 0.49 0.52 0.51 0.52	0.32 0.33 0.34 0.34 0.35	0.24 0.25 0.26 0.25 0.27	0.19 0.20 0.21 0.20 0.21	8.8 9.8 9.9 10.3 10.4	5.9 6.5 6.6 6.8 6.9	4.4 4.9 5.0 5.1 5.2	3.5 3.9 4.0 4.1 4.2	2.3 2.6 2.6 2.7 2.8	1.8 2.0 2.0 2.1 2.1	0.40 0.45 0.45 0.47 0.48
(B)1/4XP 20 R (B)1/4CP 20 L	20 30 40 50 60	XC XC XC XC XC	2.84 3.50 4.00 4.50 5.00	18.0 23.0 27.0 29.0 30.0	22.0 24.0 28.0 30.0 32.0	19.5 18.8 18.3 12.8 11.6	13.0 12.6 12.2 9.6 7.7	9.8 9.4 9.2 7.7 6.3	7.8 7.5 7.3 5.1 5.5	5.2 5.0 4.9 3.8 3.1	3.9 3.8 3.7 3.8 4.1	0.89 0.86 0.84 0.88 0.94	0.60 0.57 0.56 0.59 0.63	0.45 0.43 0.42 0.44 0.47	0.36 0.34 0.34 0.35 0.38	16.0 18.0 17.7 18.6 19.3	10.7 12.0 11.8 12.4 12.9	8.0 9.0 8.8 9.3 9.7	6.4 7.2 7.1 7.4 7.7	4.3 4.8 4.7 5.0 5.2	3.2 3.6 3.5 3.7 3.9	0.73 0.83 0.81 0.85 0.89	0.49 0.55 0.54 0.57 0.59	0.37 0.41 0.40 0.43 0.44	0.29 0.32 0.32 0.34 0.35	
(B)1/4XP 25 R (B)1/4CP 25 L	20 30 40 50 60	XC XC XC XC XC	3.48 4.26 5.00 5.50 6.00	21.0 24.0 27.0 29.0 30.0	22.0 27.0 29.0 30.0 32.0	13.7 14.6 15.3 15.6 16.5	10.3 11.0 11.5 11.7 12.4	8.2 8.8 9.2 9.4 9.9	5.5 5.9 6.1 6.3 6.6	4.1 4.4 4.6 4.7 5.0	0.94 1.0 1.0 1.1 1.1	0.63 0.67 0.70 0.72 0.76	0.47 0.50 0.52 0.54 0.57	0.38 0.40 0.42 0.43 0.45	0.36 0.39 0.40 0.42 0.45	19.6 19.5 21 23 23	13.1 13.0 14.2 15.1 15.5	9.8 9.8 10.7 11.3 11.6	7.8 7.8 8.5 8.7 9.2	5.2 5.2 6.7 6.1 6.2	3.9 3.9 4.3 4.5 4.6	0.90 0.89 0.98 1.0 1.1	0.60 0.60 0.65 0.69 0.71	0.45 0.45 0.49 0.52 0.53	0.36 0.36 0.39 0.42 0.43	
(B)1/2XP 40 R (B)1/2CP 40 L	20 30 40 50 60	XC XC XC XC XC	5.74 7.06 8.00 9.10 10.0	22.0 26.0 28.0 30.0 32.0	24.0 29.0 31.0 32.0 35.0	32 22 35 28 26	16.1 16.8 17.7 18.8 19.3	12.9 13.4 14.1 15.0 15.5	8.6 9.0 9.4 10.0 10.3	6.5 6.7 7.1 7.5 7.7	1.5 1.5 1.6 1.7 1.8	0.99 1.0 1.1 1.1 1.2	0.74 0.77 0.81 0.86 0.89	0.59 0.62 0.65 0.69 0.71	0.45 0.50 0.52 0.54 0.57	30 30 32 35 35	19.7 20 21 23 24	14.8 15.1 16.0 17.6 17.7	11.8 12.1 12.8 14.1 14.1	7.9 8.0 8.5 9.4 9.4	5.9 6.0 6.4 7.0 7.1	1.4 1.4 1.5 1.6 1.6	0.90 0.92 0.97 1.0 1.1	0.68 0.69 0.73 0.78 0.81	0.54 0.55 0.58 0.64 0.65	0.38 0.39 0.41 0.46 0.47
(B)1/2XP 80 R (B)1/2CP 80 L	20 30 40 50 60	XC XC XC XC XC	11.2 13.7 16.0 17.5 19.2	26.0 30.0 32.0 33.0 35.0	31.0 32.0 35.0 36.0 37.0	53 36 62 66 68	27 28 41 44 45	21 23 31 33 34	14.2 15.1 16.5 17.5 18.1	10.7 11.3 12.4 13.1 13.6	2.4 2.6 2.8 3.0 3.1	1.6 1.7 1.9 2.0 2.1	1.2 1.3 1.4 1.5 1.6	0.98 1.0 1.1 1.2 1.2	0.74 0.79 0.82 0.86 0.89	0.59 0.62 0.65 0.69 0.71	30 30 32 35 35	19.7 20 21 23 24	14.8 15.1 16.0 17.6 17.7	11.8 12.1 12.8 14.1 14.1	7.9 8.0 8.5 9.4 9.4	5.9 6.0 6.4 7.0 7.1	1.4 1.4 1.5 1.6 1.6	0.90 0.92 0.97 1.0 1.1	0.68 0.69 0.73 0.78 0.81	0.54 0.55 0.58 0.64 0.65

Note: Always double check your application rates.
Tabulations are based on spraying water at 70°F (21°C).

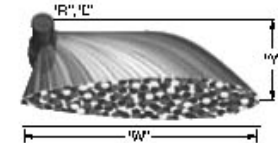

Nozzle Model	PSI	DROPSIZE	CAPACITY ONE NOZZLE IN GPM	SPRAY WIDTH "W" (FEET)		NOZZLE SPACING "X" = 0'-3"										NOZZLE SPACING "X" = 0'-3"										
				24" HEIGHT	36" HEIGHT	GPA FOR ONE NOZZLE					GALLONS PER 1000 SQ. FT.					GPA FOR ONE NOZZLE					GALLONS PER 1000 SQ. FT.					
						4 MPH	6 MPH	8 MPH	10 MPH	15 MPH	20 MPH	2 MPH	3 MPH	4 MPH	5 MPH	4 MPH	6 MPH	8 MPH	10 MPH	15 MPH	20 MPH	2 MPH	3 MPH	4 MPH	5 MPH	
				(B)1/4XP 10 R (B)1/4CP 10 L	20 30 40 50 60	XC XC XC XC XC	0.71 0.87 1.00 1.12 1.22	8.5 10.0 11.0 12.5 13.0	10.0 11.0 12.5 13.5 14.5	10.3 10.8 11.3 11.1 11.6	6.9 7.2 7.5 7.4 7.7	5.2 5.4 5.6 5.5 5.8	4.1 4.3 4.5 4.4 4.6	2.8 2.9 3.0 3.0 3.1	2.1 2.2 2.3 2.2 2.3	0.47 0.49 0.52 0.51 0.52	0.32 0.33 0.34 0.34 0.35	0.24 0.25 0.26 0.25 0.27	0.19 0.20 0.21 0.20 0.21	8.8 9.8 9.9 10.3 10.4	5.9 6.5 6.6 6.8 6.9	4.4 4.9 5.0 5.1 5.2	3.5 3.9 4.0 4.1 4.2	2.3 2.6 2.6 2.7 2.8	1.8 2.0 2.0 2.1 2.1	0.40 0.45 0.45 0.47 0.48
(B)1/4XP 20 R (B)1/4CP 20 L	20 30 40 50 60	XC XC XC XC XC	1.42 1.75 2.00 2.25 2.50	9.0 11.5 13.5 14.5 15.0	11.0 12.0 14.0 15.0 16.0	19.5 18.8 18.3 12.8 11.6	13.0 12.6 12.2 9.6 7.7	9.8 9.4 9.2 7.7 6.3	7.8 7.5 7.3 5.1 5.5	5.2 5.0 4.9 3.8 3.1	3.9 3.8 3.7 3.8 4.1	0.89 0.86 0.84 0.88 0.94	0.60 0.57 0.56 0.59 0.63	0.45 0.43 0.42 0.44 0.47	0.36 0.34 0.34 0.35 0.38	16.0 18.0 17.7 18.6 19.3	10.7 12.0 11.8 12.4 12.9	8.0 9.0 8.8 9.3 9.7	6.4 7.2 7.1 7.4 7.7	4.3 4.8 4.7 5.0 5.2	3.2 3.6 3.5 3.7 3.9	0.73 0.83 0.81 0.85 0.89	0.49 0.55 0.54 0.57 0.59	0.37 0.41 0.40 0.43 0.44	0.29 0.32 0.32 0.34 0.35	
(B)1/4XP 25 R (B)1/4CP 25 L	20 30 40 50 60	XC XC XC XC XC	1.74 2.13 2.50 2.75 3.00	11.0 12.0 13.5 14.5 15.0	11.0 12.5 14.5 15.0 16.0	13.7 14.6 15.3 15.6 16.5	10.3 11.0 11.5 11.7 12.4	8.2 8.8 9.2 9.4 9.9	5.5 5.9 6.1 6.3 6.6	4.1 4.4 4.6 4.7 5.0	0.94 1.0 1.0 1.1 1.1	0.63 0.67 0.70 0.72 0.76	0.47 0.50 0.52 0.54 0.57	0.38 0.40 0.42 0.43 0.45	0.36 0.39 0.40 0.42 0.45	19.6 19.5 21 23 23	13.1 13.0 14.2 15.1 15.5	9.8 9.8 10.7 11.3 11.6	7.8 7.8 8.5 9.1 9.2	5.2 5.2 6.7 6.1 6.2	3.9 3.9 4.3 4.5 4.6	0.90 0.89 0.98 1.0 1.1	0.60 0.60 0.65 0.69 0.71	0.45 0.45 0.49 0.52 0.53	0.36 0.36 0.39 0.42 0.43	
(B)1/2XP 40 R (B)1/2CP 40 L	20 30 40 50 60	XC XC XC XC XC	2.87 3.53 4.00 4.55 5.00	11.0 13.0 14.0 15.5 16.0	12.0 14.5 15.5 16.0 17.5	32 24 35 28 26	16.1 16.8 17.7 18.8 19.3	12.9 13.4 14.1 15.0 15.5	8.6 9.0 9.4 10.0 10.3	6.5 6.7 7.1 7.5 7.7	1.5 1.5 1.6 1.7 1.8	0.99 1.0 1.1 1.1 1.2	0.74 0.77 0.81 0.86 0.89	0.59 0.62 0.65 0.69 0.71	0.45 0.50 0.52 0.54 0.57	30 30 32 35 35	19.7 20 21 23 24	14.8 15.1 16.0 17.6 17.7	11.8 12.1 12.8 14.1 14.1	7.9 8.0 8.5 9.4 9.4	5.9 6.0 6.4 7.0 7.1	1.4 1.4 1.5 1.6 1.6	0.90 0.92 0.97 1.0 1.1	0.68 0.69 0.73 0.78 0.81	0.54 0.55 0.58 0.64 0.65	
(B)1/2XP 80 R (B)1/2CP 80 L	20 30 40 50 60	XC XC XC XC XC	5.60 6.83 8.00 8.73 9.60	13.0 15.0 16.5 17.5 18.5	15.5 16.5 17.5 18.0 18.5	53 36 62 65 68	27 28 41 44 45	21 23 31 33 34	14.2 15.0 16.5 17.5 18.1	10.7 11.3 12.4 13.1 13.6	2.4 2.6 2.8 3.0 3.1	1.6 1.7 1.9 2.0 2.1	1.2 1.3 1.4 1.5 1.6	0.98 1.0 1.1 1.2 1.2	0.74 0.79 0.82 0.86 0.89	0.59 0.62 0.65 0.69 0.71	30 30 32 35 35	19.7 20 21 23 24	14.8 15.1 16.0 17.6 17.7	11.8 12.1 12.8 14.1 14.1	7.9 8.0 8.5 9.4 9.4	5.9 6.0 6.4 7.0 7.1	1.4 1.4 1.5 1.6 1.6	0.90 0.92 0.97 1.0 1.1	0.68 0.69 0.73 0.78 0.81	0.54 0.55 0.58 0.64 0.65

Note: Always double check your application rates.
Tabulations are based on spraying water at 70°F (21°C).



BOOMLESS NOZZLES



BoomJet® Boomless Nozzles with Extra-Wide Flat Spray Projection



5880-3/4 NPT Female
Back inlet connection.
Weight: Brass 2 lbs.

Type 5880 BoomJet nozzle is used for spraying areas not easily accessed with a boom sprayer. It combines two off-center tips and three VeeJet® nozzles to produce an overall wide swath flat spray. The nozzle assembly provides good distribution considering the wide pattern coverage obtained; however, the uniformity is not as good as with a properly operated boom sprayer.* Supplied with one additional 1/4" NPT pipe plug and one blank tip for setting BoomJet to one side only. Also has a 1/4" NPT pressure gauge port.

*Uniformity can be optimized by double overlapping spray swaths on successive sprayer passes. Remember, this also doubles the application volume.



W = Maximum effective coverage with nozzle mounted at 36" height.

Image	OC (2)	H1 (2)	H1 (1)	PSI	GPM	"W" (FEET)	GPA					GALLONS PER 1000 SQ. FT.			
							4 MPH	5 MPH	7.5 MPH	10 MPH	15 MPH	2 MPH	3 MPH	4 MPH	5 MPH
5880-3/4-2TOC06	6733-OC06	H1/4VV-1506	H1/4VVL-9502 with 50 mesh strainer	20	1.84	33.5	6.8	5.4	3.6	2.7	1.8	0.31	0.21	0.16	0.12
				30	2.25	34	8.2	6.6	4.4	3.3	2.2	0.38	0.25	0.19	0.15
				40	2.60	34.5	9.3	7.5	5.0	3.7	2.5	0.43	0.28	0.21	0.17
5880-3/4-2TOC10	OC10	H1/4U-0508HE	H1/4VVL-11004 with 50 mesh strainer	20	2.83	39.5	8.9	7.1	4.7	3.5	2.4	0.41	0.27	0.20	0.16
				30	3.46	40	10.7	8.6	5.7	4.3	2.9	0.49	0.33	0.25	0.20
				40	4.00	40.5	12.2	9.8	6.5	4.9	3.3	0.56	0.37	0.28	0.22
5880-3/4-2TOC20	OC20	H1/4U-0520HE	H1/4VVL-9506 with 50 mesh strainer	20	6.08	47	16.0	12.8	8.5	6.4	4.3	0.73	0.49	0.37	0.29
				30	7.45	50	18.4	14.8	9.8	7.4	4.9	0.84	0.56	0.42	0.34
				40	8.60	52	20	16.4	10.9	8.2	5.5	0.94	0.62	0.47	0.37
5880-3/4-2TOC40	OC40	H1/4U-0540HE	H1/4U-9510	20	12.0	56	27	21	14.1	10.6	7.1	1.2	0.81	0.61	0.49
				30	14.7	60	30	24	16.2	12.1	8.1	1.4	0.93	0.69	0.56
				40	17.0	63	33	27	17.8	13.4	8.9	1.5	1.0	0.76	0.61

Note: Always double check your application rates. Tabulations are based on spraying water at 70°F (21°C).



TeeJet® Swivel Spray Nozzles with Off-Center Flat Spray Tips — Larger Capacities

Large capacity swivel nozzles, available in both single or double styles, are available with 3/4" NPT (F) inlet connections for use as boomless type nozzles. For double swivels the tabulated GPM (l/min) capacities are twice those shown for single swivels.

Extra Wide Flat Spray Coverage

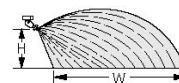

W = Maximum effective coverage with nozzle mounted at 36" height.



Type 4629-3/4-TOC Single Swivel
with 3/4" NPT (F) pipe connection. Brass.

Type 4418-3/4-2TOC Double Swivel
with 3/4" NPT (F) pipe connection. Brass.



Image	PSI	GPM	"W" (FEET)	HEIGHT = 36"		
				GPA		
				5 MPH	10 MPH	15 MPH
4629-3/4-TOC10	30	0.87	18	4.8	2.4	1.6
	40	1.00	18.5	5.4	2.7	1.8
	60	1.22	18.5	6.5	3.3	2.2
4629-3/4-TOC20	30	1.73	23.5	7.3	3.6	2.4
	40	2.00	24.5	8.1	4.0	2.7
	60	2.45	24.5	9.9	5.0	3.3
4629-3/4-TOC40	30	3.46	26	13.2	6.6	4.4
	40	4.00	27	14.7	7.3	4.9
	60	4.90	27	18.0	9.0	6.0
4629-3/4-TOC80	30	6.93	29	24	11.8	7.9
	40	8.00	30	26	13.2	8.8
	60	9.80	30	32	16.2	10.8
4629-3/4-TOC150	30	13.0	30.5	42	21	14.1
	40	15.0	31.5	47	24	15.7
	60	18.4	31.5	58	29	19.3
4629-3/4-TOC300	30	26.0	32	80	40	27
	40	30.0	33	90	45	30
	60	36.7	33.5	108	54	36

Note: Always double check your application rates. Tabulations are based on spraying water at 70°F (21°C).

AI TeeJet® Air Induction Even Flat Spray Tips



- Depending on the chemical, produces large air-filled drops through the use of a Venturi air aspirator.
- Ideal for banding over the row or in row middles.
- Automatic spray alignment with Quick TeeJet® cap

Features:

- Available with stainless steel insert, polymer holder and pre-orifice with VisiFlo® color-coding.
- Larger droplets for less drift.



Note: Due to the pre-orifice design, this tip is not compatible with the 4193A check valve tip strainer.

NOZZLE SIZE	PSI	DROPS PER MIN.	CAPACITY ONE NOZZLE IN OZ./MIN.	GPA Δ 30° Δ Field Acres												
				3 MPH	3.5 MPH	4 MPH	4.5 MPH	5 MPH	5.5 MPH	6 MPH	6.5 MPH	7 MPH	7.5 MPH	8 MPH	8.5 MPH	
AI95015EVS (100)	30	VC	0.13	17	8.6	7.4	6.4	5.7	5.1	4.7	4.3	4.0	3.7	3.4	3.2	3.0
	40	VC	0.15	19	9.9	8.5	7.4	6.6	5.9	5.4	5.0	4.6	4.2	4.0	3.7	3.5
	50	VC	0.17	22	11.2	9.6	8.4	7.5	6.7	6.1	5.6	5.2	4.8	4.5	4.2	4.0
	60	C	0.18	23	11.9	10.2	8.9	7.9	7.1	6.5	5.9	5.5	5.1	4.8	4.5	4.2
	70	C	0.20	26	13.2	11.3	9.9	8.8	7.9	7.2	6.6	6.1	5.7	5.3	5.0	4.7
	80	C	0.21	27	13.9	11.9	10.4	9.2	8.3	7.6	6.9	6.4	5.9	5.5	5.2	4.9
	100	C	0.23	29	15.2	13.0	11.4	10.1	9.1	8.3	7.6	7.0	6.5	6.1	5.7	5.4
AI9502EVS (50)	30	VC	0.17	22	11.2	9.6	8.4	7.5	6.7	6.1	5.6	5.2	4.8	4.5	4.2	4.0
	40	VC	0.20	26	13.2	11.3	9.9	8.8	7.9	7.2	6.6	6.1	5.7	5.3	5.0	4.7
	50	VC	0.22	28	14.5	12.4	10.9	9.7	8.7	7.9	7.3	6.7	6.2	5.8	5.4	5.1
	60	C	0.24	31	15.8	13.6	11.9	10.6	9.5	8.6	7.9	7.3	6.8	6.3	5.9	5.6
	70	C	0.26	33	17.2	14.7	12.9	11.4	10.3	9.4	8.6	7.9	7.4	6.9	6.4	6.1
	80	C	0.28	36	18.5	15.8	13.9	12.3	11.1	10.1	9.2	8.5	7.9	7.4	6.9	6.5
	100	C	0.30	38	19.8	17.0	14.9	13.2	11.9	10.8	9.9	9.1	8.5	7.9	7.4	7.0
AI9502SEVS (50)	30	VC	0.22	28	14.5	12.4	10.9	9.7	8.7	7.9	7.3	6.7	6.2	5.8	5.4	5.1
	40	VC	0.25	32	16.5	14.1	12.4	11.0	9.9	9.0	8.3	7.6	7.1	6.6	6.2	5.8
	50	VC	0.28	36	18.5	15.8	13.9	12.3	11.1	10.1	9.2	8.5	7.9	7.4	6.9	6.5
	60	VC	0.31	40	20	17.5	15.3	13.6	12.3	11.2	10.2	9.4	8.8	8.2	7.7	7.2
	70	VC	0.33	42	22	18.7	16.3	14.5	13.1	11.9	10.9	10.1	9.3	8.7	8.2	7.7
	80	C	0.35	45	23	19.8	17.3	15.4	13.9	12.6	11.6	10.7	9.9	9.2	8.7	8.2
	100	C	0.38	49	25	21	18.8	16.7	15.0	13.7	12.5	11.6	10.7	10.0	9.4	8.9
AI9503EVS (50)	30	XC	0.40	51	26	23	19.8	17.6	15.8	14.4	13.2	12.2	11.3	10.6	9.9	9.3
	40	XC	0.26	33	17.2	14.7	12.9	11.4	10.3	9.4	8.6	7.9	7.4	6.9	6.4	6.1
	50	VC	0.30	38	19.8	17.0	14.9	13.2	11.9	10.8	9.9	9.1	8.5	7.9	7.4	7.0
	60	VC	0.34	44	22	19.2	16.8	15.0	13.5	12.2	11.2	10.4	9.6	9.0	8.4	7.9
	70	VC	0.37	47	24	21	18.3	16.3	14.7	13.3	12.2	11.3	10.5	9.8	9.2	8.6
	80	VC	0.40	51	26	23	19.8	17.6	15.8	14.4	13.2	12.2	11.3	10.6	9.9	9.3
	100	C	0.42	54	28	24	21	18.5	16.6	15.1	13.9	12.8	11.9	11.1	10.4	9.8
AI9504EVS (50)	30	XC	0.45	58	30	25	22	19.8	17.8	16.2	14.9	13.7	12.7	11.9	11.1	10.5
	40	XC	0.47	60	31	27	23	21	18.6	16.9	15.5	14.3	13.3	12.4	11.6	10.9
	50	VC	0.45	58	30	25	22	19.8	17.8	16.2	14.9	13.7	12.7	11.9	11.1	10.5
	60	VC	0.49	63	32	28	24	22	19.4	17.6	16.2	14.9	13.9	12.9	12.1	11.4
	70	VC	0.53	68	35	30	26	23	21	19.1	17.5	16.1	15.0	14.0	13.1	12.3
	80	VC	0.57	73	38	32	28	25	23	21	18.8	17.4	16.1	15.0	14.1	13.3
	100	C	0.60	77	40	34	30	26	24	22	19.8	18.3	17.0	15.8	14.9	14.0
AI9505EVS (50)	30	XC	0.63	81	42	36	31	28	25	23	21	19.2	17.8	16.6	15.6	14.7
	40	XC	0.43	55	28	24	21	18.9	17.0	15.5	14.2	13.1	12.2	11.4	10.6	10.0
	50	VC	0.50	64	33	28	25	22	19.8	18.0	16.5	15.2	14.1	13.2	12.4	11.6
	60	VC	0.56	72	37	32	28	25	22	20	18.5	17.1	15.8	14.8	13.9	13.0
	70	VC	0.61	78	40	35	30	27	24	22	20	18.6	17.3	16.1	15.1	14.2
	80	VC	0.66	84	44	37	33	29	26	24	22	20	18.7	17.4	16.3	15.4
	100	C	0.71	91	47	40	35	31	28	26	23	22	20	18.7	17.6	16.5
AI9506EVS (50)	30	XC	0.75	96	50	42	37	33	30	27	25	23	21	19.8	18.6	17.5
	40	XC	0.79	101	52	45	39	35	31	28	26	24	22	21	19.6	18.4
	50	VC	0.52	67	34	29	26	23	21	18.7	17.2	15.8	14.7	13.7	12.9	12.1
	60	VC	0.60	77	40	34	30	26	24	22	19.8	18.3	17.0	15.8	14.9	14.0
	70	VC	0.67	86	44	38	33	29	27	24	22	20	19.0	17.7	16.6	15.6
	80	VC	0.73	93	48	41	36	32	29	26	24	22	21	19.3	18.1	17.0
	100	C	0.79	101	52	45	39	35	31	28	26	24	22	21	19.6	18.4
AI9508EVS (50)	30	XC	0.85	109	56	48	42	37	34	31	28	26	24	22	21	19.8
	40	XC	0.90	115	59	51	45	40	36	32	30	27	25	24	22	21
	50	VC	0.95	122	63	54	47	42	38	34	31	29	27	25	24	22
	60	VC	0.69	88	46	39	34	30	27	25	23	21	19.5	18.2	17.1	16.1
	70	VC	0.80	102	53	45	40	35	32	29	26	24	23	21	19.8	18.6
	80	VC	0.89	114	59	50	44	39	35	32	29	27	25	23	22	21
	100	C	0.98	125	65	55	49	43	39	35	32	30	28	26	24	23
AI9508SEVS (50)	30	VC	1.06	136	70	60	52	47	42	38	35	32	30	28	26	25
	40	VC	1.13	145	75	64	56	50	45	41	37	34	32	30	28	26
	50	VC	1.20	154	79	68	59	53	48	43	40	37	34	32	30	28
	60	VC	1.26	161	83	71	62	55	50	45	42	38	36	33	31	29

Note: Always double check your application rates. Tabulations are based on spraying water at 70°F (21°C).



CONTACT PRODUCT	SYSTEMIC PRODUCT	DRIFT MANAGEMENT
GOOD	EXCELLENT	EXCELLENT

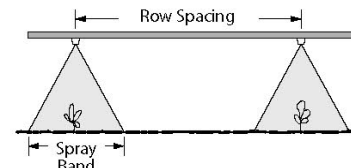

NOZZLE SIZE	ROW SPACING	GPA CONVERSION FACTORS*	
		20°	30°
8"	4"	2.50	3.75
10"	5"	2.00	3.00
12"	5"	1.67	2.50
15"	7"	1.33	2.00

*To find GPA rate on band widths, multiply the tabulated GPA for ROW SPACING by conversion factors.

BANDING NOZZLES

DG TeeJet® Drift Guard Even Flat Spray Tips

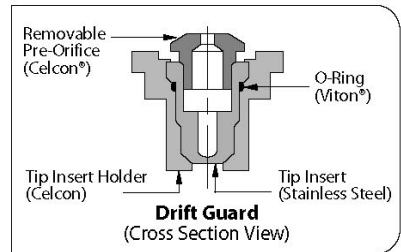

Note: Due to the pre-orifice design, this tip is not compatible with the 4193A check valve.

Typical Applications:

Can be used for pre-emerge surface-applied herbicides or post-emerge systemic herbicide applications.

- Ideal for banding over the row or in row middles.
- Provides uniform distribution throughout the flat spray pattern.
- Easily mounted on spray boom or planter.
- Stainless steel with VisiFlo® color-coding.

Features:

- Pre-orifice design produces large droplets to reduce drift.

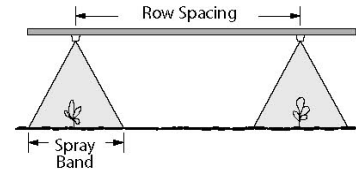

Nozzle Model	PSI	DROP SIZE	CAPACITY ONE NOZZLE IN GPM	CAPACITY ONE NOZZLE IN OZ./MIN.	GPA Field Acres											
					3 MPH	3.5 MPH	4 MPH	4.5 MPH	5 MPH	5.5 MPH	6 MPH	6.5 MPH	7 MPH	7.5 MPH	8 MPH	8.5 MPH
DG9501EVS (100)	30	M	0.13	17	8.6	7.4	6.4	5.7	5.1	4.7	4.3	4.0	3.7	3.4	3.2	3.0
	40	M	0.15	19	9.9	8.5	7.4	6.6	5.9	5.4	5.0	4.6	4.2	4.0	3.7	3.5
	50	F	0.17	22	11.2	9.6	8.4	7.5	6.7	6.1	5.6	5.2	4.8	4.5	4.2	4.0
	60	F	0.18	23	11.9	10.2	8.9	7.9	7.1	6.5	5.9	5.5	5.1	4.8	4.5	4.2
DG9502EVS (50)	30	M	0.17	22	11.2	9.6	8.4	7.5	6.7	6.1	5.6	5.2	4.8	4.5	4.2	4.0
	40	M	0.20	26	13.2	11.3	9.9	8.8	7.9	7.2	6.6	6.1	5.7	5.3	5.0	4.7
	50	M	0.22	28	14.5	12.4	10.9	9.7	8.7	7.9	7.3	6.7	6.2	5.8	5.4	5.1
	60	M	0.24	31	15.8	13.6	11.9	10.6	9.5	8.6	7.9	7.3	6.8	6.3	5.9	5.6
DG9503EVS (50)	30	C	0.26	33	17.2	14.7	12.9	11.4	10.3	9.4	8.6	7.9	7.4	6.9	6.4	6.1
	40	M	0.30	38	19.8	17.0	14.9	13.2	11.9	10.8	9.9	9.1	8.5	7.9	7.4	7.0
	50	M	0.34	44	22	19.2	16.8	15.0	13.5	12.2	11.2	10.4	9.6	9.0	8.4	7.9
	60	M	0.37	47	24	21	18.3	16.3	14.7	13.3	12.2	11.3	10.5	9.8	9.2	8.6
DG9504EVS (50)	30	C	0.35	45	23	19.8	17.3	15.4	13.9	12.6	11.6	10.7	9.9	9.2	8.7	8.2
	40	C	0.40	51	26	23	19.8	17.6	15.8	14.4	13.2	12.2	11.3	10.6	9.9	9.3
	50	M	0.45	58	30	25	22	19.8	17.8	16.2	14.9	13.7	12.7	11.9	11.1	10.5
	60	M	0.49	63	32	28	24	22	19.4	17.6	16.2	14.9	13.9	12.9	12.1	11.4
DG9505EVS (50)	30	C	0.43	55	28	24	21	18.9	17.0	15.5	14.2	13.1	12.2	11.4	10.6	10.0
	40	C	0.50	64	33	28	25	22	19.8	18.0	16.5	15.2	14.1	13.2	12.4	11.6
	50	M	0.56	72	37	32	28	25	22	20	18.5	17.1	15.8	14.8	13.9	13.0
	60	M	0.61	78	40	35	30	27	24	22	20	18.6	17.3	16.1	15.1	14.2

Note: Always double check your application rates. Tabulations are based on spraying water at 70°F (21°C).



Nozzle Model	PSI	DROP SIZE	GPA CONVERSION FACTORS*	
			20°	30°
8"	4"		2.50	3.75
10"	5"		2.00	3.00
12"	5"		1.67	2.50
15"	7"		1.33	2.00

*To find GPA rate on band widths, multiply the tabulated GPA for ROW SPACING by conversion factors.

BANDING NOZZLES



Features:

- Ideal for banding over the row or in row middles.
- Provides uniform distribution throughout the flat spray pattern.
- Easily mounted on spray boom or planter.
- Available with VisiFlo® color-coding in stainless steel or all stainless steel, hardened stainless steel and brass.



TIPO	PSI	CAPACITY ONE NOZZLE IN GPM	GPA Field Acres											
			3 MPH	3.5 MPH	4 MPH	4.5 MPH	5 MPH	5.5 MPH	6 MPH	6.5 MPH	7 MPH	7.5 MPH	8 MPH	8.5 MPH
TP4001E†	20	0.071	4.7	4.0	3.5	3.1	2.8	2.6	2.3	2.2	2.0	1.9	1.8	1.7
TP6501E†	30	0.087	5.7	4.9	4.3	3.8	3.4	3.1	2.9	2.7	2.5	2.3	2.2	2.0
TP8001E	40	0.10	6.6	5.7	5.0	4.4	4.0	3.6	3.3	3.0	2.8	2.6	2.5	2.3
TP9501E (100)	50	0.11	7.3	6.2	5.4	4.8	4.4	4.0	3.6	3.4	3.1	2.9	2.7	2.6
TP40015E†	60	0.12	7.9	6.8	5.9	5.3	4.8	4.3	4.0	3.7	3.4	3.2	3.0	2.8
TP40015E†	20	0.11	7.3	6.2	5.4	4.8	4.4	4.0	3.6	3.4	3.1	2.9	2.7	2.6
TP65015E†	30	0.13	8.6	7.4	6.4	5.7	5.1	4.7	4.3	4.0	3.7	3.4	3.2	3.0
TP80015E	40	0.15	9.9	8.5	7.4	6.6	5.9	5.4	5.0	4.6	4.2	4.0	3.7	3.5
TP95015E (100)	50	0.17	11.2	9.6	8.4	7.5	6.7	6.1	5.6	5.2	4.8	4.5	4.2	4.0
TP4002E†	60	0.18	11.9	10.2	8.9	7.9	7.1	6.5	5.9	5.5	5.1	4.8	4.5	4.2
TP4002E†	20	0.14	9.2	7.9	6.9	6.2	5.5	5.0	4.6	4.3	4.0	3.7	3.5	3.3
TP6502E†	30	0.17	11.2	9.6	8.4	7.5	6.7	6.1	5.6	5.2	4.8	4.5	4.2	4.0
TP8002E	40	0.20	13.2	11.3	9.9	8.8	7.9	7.2	6.6	6.1	5.7	5.3	5.0	4.7
TP9502E (50)	50	0.22	14.5	12.4	10.9	9.7	8.7	7.9	7.3	6.7	6.2	5.8	5.4	5.1
TP4003E†	60	0.24	15.8	13.6	11.9	10.6	9.5	8.6	7.9	7.3	6.8	6.3	5.9	5.6
TP4003E†	20	0.21	13.9	11.9	10.4	9.2	8.3	7.6	6.9	6.4	5.9	5.5	5.2	4.9
TP6503E†	30	0.26	17.2	14.7	12.9	11.4	10.3	9.4	8.6	7.9	7.4	6.9	6.4	6.1
TP8003E	40	0.30	19.8	17.0	14.9	13.2	11.9	10.8	9.9	9.1	8.5	7.9	7.4	7.0
TP9503E (50)	50	0.34	22	19.2	16.8	15.0	13.5	12.2	11.2	10.4	9.6	9.0	8.4	7.9
TP4004E†	60	0.37	24	21	18.3	16.3	14.7	13.3	12.2	11.3	10.5	9.8	9.2	8.6
TP4004E†	20	0.28	18.5	15.8	13.9	12.3	11.1	10.1	9.2	8.5	7.9	7.4	6.9	6.5
TP6504E†	30	0.35	23	19.8	17.3	15.4	13.9	12.6	11.6	10.7	9.9	9.2	8.7	8.2
TP8004E	40	0.40	26	23	19.8	17.6	15.8	14.4	13.2	12.2	11.3	10.6	9.9	9.3
TP9504E (50)	50	0.45	30	25	22	19.8	17.8	16.2	14.9	13.7	12.7	11.9	11.1	10.5
TP4005E†	60	0.49	32	28	24	22	19.4	17.6	16.2	14.9	13.9	12.9	12.1	11.4
TP4005E†	20	0.35	23	19.8	17.3	15.4	13.9	12.6	11.6	10.7	9.9	9.2	8.7	8.2
TP6505E†	30	0.43	28	24	21	18.9	17.0	15.5	14.2	13.1	12.2	11.4	10.6	10.0
TP8005E	40	0.50	33	28	25	22	19.8	18.0	16.5	15.2	14.1	13.2	12.4	11.6
TP9505E (50)	50	0.56	37	32	28	25	22	20	18.5	17.1	15.8	14.8	13.9	13.0
TP4006E†	60	0.61	40	35	30	27	24	22	20	18.6	17.3	16.1	15.1	14.2
TP4006E†	20	0.42	28	24	21	18.5	16.6	15.1	13.9	12.8	11.9	11.1	10.4	9.8
TP6506E†	30	0.52	34	29	26	23	21	18.7	17.2	15.8	14.7	13.7	12.9	12.1
TP8006E	40	0.60	40	34	30	26	24	22	19.8	18.3	17.0	15.8	14.9	14.0
TP9506E (50)	50	0.67	44	38	33	29	27	24	22	20	19.0	17.7	16.6	15.6
TP6508E†	60	0.73	48	41	36	32	29	26	24	22	21	19.3	18.1	17.0
TP6508E†	20	0.57	38	32	28	25	23	21	18.8	17.4	16.1	15.0	14.1	13.3
TP11008E†	30	0.69	46	39	34	30	27	25	23	21	19.5	18.2	17.1	16.1
TP8008E	40	0.80	53	45	40	35	32	29	26	24	23	21	19.8	18.6
TP9508E (50)	50	0.89	59	50	44	39	35	32	29	27	25	23	22	21
TP4010E†	60	0.98	65	55	49	43	39	35	32	30	28	26	24	23
TP4010E†	20	0.71	47	40	35	31	28	26	23	22	20	18.7	17.6	16.5
TP6510E†	30	0.87	57	49	43	38	34	31	29	27	25	23	22	20
TP8010E	40	1.00	66	57	50	44	40	36	33	30	28	26	25	23
TP11010E† (24)	50	1.12	74	63	55	49	44	40	37	34	32	30	28	26
TP4015E†	60	1.22	81	69	60	54	48	44	40	37	35	32	30	28
TP4015E†	20	1.06	70	60	52	47	42	38	35	32	30	28	26	25
TP6515E†	30	1.30	86	74	64	57	51	47	43	40	37	34	32	30
TP8015E†	40	1.50	99	85	74	66	59	54	50	46	42	40	37	35
TP95015E†	50	1.68	111	95	83	74	67	60	55	51	48	44	42	39
TP11015E†	60	1.84	121	104	91	81	73	66	61	56	52	49	46	43

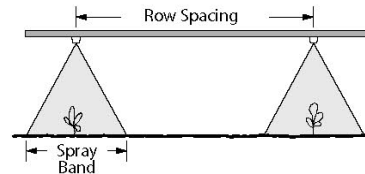

TIPO	GPA CONVERSION FACTORS*					GPA CONVERSION FACTORS*	
	40°	65°	80°	95°	110°	20'	30'
8"	11"	6"	5"	4"	3"	2.50	3.75
10"	14"	8"	6"	5"	4"	2.00	3.00
12"	16"	9"	7"	5"	4"	1.67	2.50
15"	21"	12"	9"	7"	5"	1.33	2.00

*To find GPA rate on band widths, multiply the tabulated GPA for ROW SPACING by conversion factors.

Note: Always double check your application rates. Tabulations are based on spraying water at 70°F (21°C).

†Available in brass, stainless steel and hardened stainless steel only.



40° and 80° E Series

TwinJet even tips combine the advantages of twin flat spray patterns with even distribution across the pattern. The twin flat sprays provide improved coverage of crop or weed without sacrificing uniformity. The smaller droplet size makes this tip ideal for providing a thorough, penetrating coverage with post-emergence contact herbicides.

These tips also provide good pre-emergence coverage on cloddy fields and fields covered with crop residue.

Features:

- Ideal for banding over or between crop rows.
- Provides uniform distribution throughout the spray pattern.
- Available in 80° and 40° twin flat spray patterns.
- Made of stainless steel with VisiFlo® coding.
- Can be used with Quick TeeJet® cap.

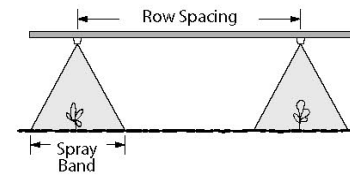

TIPO	PSI	DROPSIZE	CAPACITY ONE NOZZLE IN GPM	CAPACITY ONE NOZZLE IN OZ./MIN.	GPA Field Acres											
					3 MPH	3.5 MPH	4 MPH	4.5 MPH	5 MPH	5.5 MPH	6 MPH	6.5 MPH	7 MPH	7.5 MPH	8 MPH	8.5 MPH
TJ60-4002EVS TJ60-8002EVS (100)	30	F	0.17	22	11.2	9.6	8.4	7.5	6.7	6.1	5.6	5.2	4.8	4.5	4.2	4.0
	40	F	0.20	26	13.2	11.3	9.9	8.8	7.9	7.2	6.6	6.1	5.7	5.3	5.0	4.7
	50	F	0.22	28	14.5	12.4	10.9	9.7	8.7	7.9	7.3	6.7	6.2	5.8	5.4	5.1
	60	F	0.24	31	15.8	13.6	11.9	10.6	9.5	8.6	7.9	7.3	6.8	6.3	5.9	5.6
TJ60-4003EVS TJ60-8003EVS (100)	30	F	0.26	33	17.2	14.7	12.9	11.4	10.3	9.4	8.6	7.9	7.4	6.9	6.4	6.1
	40	F	0.30	38	19.8	17.0	14.9	13.2	11.9	10.8	9.9	9.1	8.5	7.9	7.4	7.0
	50	F	0.34	44	22	19.2	16.8	15.0	13.5	12.2	11.2	10.4	9.6	9.0	8.4	7.9
	60	F	0.37	47	24	21	18.3	16.3	14.7	13.3	12.2	11.3	10.5	9.8	9.2	8.6
TJ60-4004EVS TJ60-8004EVS (50)	30	M	0.35	45	23	19.8	17.3	15.4	13.9	12.6	11.6	10.7	9.9	9.2	8.7	8.2
	40	F	0.40	51	26	23	19.8	17.6	15.8	14.4	13.2	12.2	11.3	10.6	9.9	9.3
	50	F	0.45	58	30	25	22	19.8	17.8	16.2	14.9	13.7	12.7	11.9	11.1	10.5
	60	F	0.49	63	32	28	24	22	19.4	17.6	16.2	14.9	13.9	12.9	12.1	11.4
TJ60-8006EVS (50)	30	M	0.52	67	34	29	26	23	21	18.7	17.2	15.8	14.7	13.7	12.9	12.1
	40	M	0.60	77	40	34	30	26	24	22	19.8	18.3	17.0	15.8	14.9	14.0
	50	M	0.67	86	44	38	33	29	27	24	22	20	19.0	17.7	16.6	15.6
	60	M	0.73	93	48	41	36	32	29	26	24	22	21	19.3	18.1	17.0

TIPO	GPA CONVERSION FACTORS*		GPA CONVERSION FACTORS*	
	40°	80°	20°	30°
8"	11"	5"	2.50	3.75
10"	14"	6"	2.00	3.00
12"	16"	7"	1.67	2.50
15"	21"	9"	1.33	2.00

*To find GPA rate on band widths, multiply the tabulated GPA for ROW SPACING by conversion factors.

Note: Always double check your application rates. Tabulations are based on spraying water at 70°F (21°C).

● Very Fine ● Fine ○ Medium ● Coarse ● Very Coarse ○ Extremely Coarse

BANDING NOZZLES



StreamJet® SJ-3 Fertilizer Nozzles



Features:

- VisiFlo® color-coding system.
- Three solid streams of equal velocity and capacity.
- Removable metering orifice for easy cleaning.
- Ten sizes for a wide range of application rates.
- Equally spaced distribution at 20° (50 cm) height.
- All acetel construction for excellent chemical resistance.
- Recommended operating pressure: 20–60 PSI (1.5–4 bar).



Nozzle Model	PSI	CAPACITY ONE NOZZLE IN GPM	GPA 20°										
			3 MPH	4 MPH	5 MPH	6 MPH	8 MPH	10 MPH	12 MPH	14 MPH	16 MPH	18 MPH	20 MPH
SJ3-015-VP (100)	20	0.11	10.9	8.2	6.5	5.4	4.1	3.3	2.7	2.3	2.0	1.8	1.6
	30	0.13	12.9	9.7	7.7	6.4	4.8	3.9	3.2	2.8	2.4	2.1	1.9
	40	0.15	14.9	11.1	8.9	7.4	5.6	4.5	3.7	3.2	2.8	2.5	2.2
	50	0.16	15.8	11.9	9.5	7.9	5.9	4.8	4.0	3.4	3.0	2.6	2.4
	60	0.17	16.8	12.6	10.1	8.4	6.3	5.0	4.2	3.6	3.2	2.8	2.5
SJ3-02-VP (50)	20	0.14	13.9	10.4	8.3	6.9	5.2	4.2	3.5	3.0	2.6	2.3	2.1
	30	0.17	16.8	12.6	10.1	8.4	6.3	5.0	4.2	3.6	3.2	2.8	2.5
	40	0.20	19.8	14.9	11.9	9.9	7.4	5.9	5.0	4.2	3.7	3.3	3.0
	50	0.21	21	15.6	12.5	10.4	7.8	6.2	5.2	4.5	3.9	3.5	3.1
	60	0.22	22	16.3	13.1	10.9	8.2	6.5	5.4	4.7	4.1	3.6	3.3
SJ3-03-VP (50)	20	0.24	24	17.8	14.3	11.9	8.9	7.1	5.9	5.1	4.5	4.0	3.6
	30	0.27	27	20	16.0	13.4	10.0	8.0	6.7	5.7	5.0	4.5	4.0
	40	0.30	30	22	17.8	14.9	11.1	8.9	7.4	6.4	5.6	5.0	4.5
	50	0.33	33	25	19.6	16.3	12.3	9.8	8.2	7.0	6.1	5.4	4.9
	60	0.35	35	26	21	17.3	13.0	10.4	8.7	7.4	6.5	5.8	5.2
SJ3-04-VP (50)	20	0.30	30	22	17.8	14.9	11.1	8.9	7.4	6.4	5.6	5.0	4.5
	30	0.36	36	27	21	17.8	13.4	10.7	8.9	7.6	6.7	5.9	5.3
	40	0.40	40	30	24	19.8	14.9	11.9	9.9	8.5	7.4	6.6	5.9
	50	0.43	43	32	26	21	16.0	12.8	10.6	9.1	8.0	7.1	6.4
	60	0.47	47	35	28	23	17.4	14.0	11.6	10.0	8.7	7.8	7.0
SJ3-05-VP (50)	20	0.36	36	27	21	17.8	13.4	10.7	8.9	7.6	6.7	5.9	5.3
	30	0.45	45	33	27	22	16.7	13.4	11.1	9.5	8.4	7.4	6.7
	40	0.50	50	37	30	25	18.6	14.9	12.4	10.6	9.3	8.3	7.4
	50	0.55	54	41	33	27	20	16.3	13.6	11.7	10.2	9.1	8.2
	60	0.59	58	44	35	29	22	17.5	14.6	12.5	11.0	9.7	8.8
SJ3-06-VP (50)	20	0.42	42	31	25	21	15.6	12.5	10.4	8.9	7.8	6.9	6.2
	30	0.54	53	40	32	27	20	16.0	13.4	11.5	10.0	8.9	8.0
	40	0.60	59	45	36	30	22	17.8	14.9	12.7	11.1	9.9	8.9
	50	0.66	65	49	39	33	25	19.6	16.3	14.0	12.3	10.9	9.8
	60	0.70	69	52	42	35	26	21	17.3	14.9	13.0	11.6	10.4
SJ3-08-VP	20	0.56	55	42	33	28	21	16.6	13.9	11.9	10.4	9.2	8.3
	30	0.72	71	53	43	36	27	21	17.8	15.3	13.4	11.9	10.7
	40	0.80	79	59	48	40	30	24	19.8	17.0	14.9	13.2	11.9
	50	0.88	87	65	52	44	33	26	22	18.7	16.3	14.5	13.1
	60	0.94	93	70	56	47	35	28	23	19.9	17.4	15.5	14.0
SJ3-10-VP	20	0.65	64	48	39	32	24	19.3	16.1	13.8	12.1	10.7	9.7
	30	0.90	89	67	53	45	33	27	22	19.1	16.7	14.9	13.4
	40	1.00	99	74	59	50	37	30	25	21	18.6	16.5	14.9
	50	1.11	110	82	66	55	41	33	27	24	21	18.3	16.5
	60	1.19	118	88	71	59	44	35	29	25	22	19.6	17.7
SJ3-15-VP	20	0.99	98	74	59	49	37	29	25	21	18.4	16.3	14.7
	30	1.24	123	92	74	61	46	37	31	26	23	20	18.4
	40	1.50	149	111	89	74	56	45	37	32	28	25	22
	50	1.68	166	125	100	83	62	50	42	36	31	28	25
	60	1.83	181	136	109	91	68	54	45	39	34	30	27
SJ3-20-VP	20	1.41	140	105	84	70	52	42	35	30	26	23	21
	30	1.75	173	130	104	87	65	52	43	37	32	29	26
	40	2.00	198	149	119	99	74	59	50	42	37	33	30
	50	2.28	226	169	135	113	85	68	56	48	42	38	34
	60	2.49	247	185	148	123	92	74	62	53	46	41	37

Note: Always double check your application rates. Tabulations are based on spraying water at 70°F (21°C).

FERTILIZER NOZZLES

StreamJet® SJ-7 Fertilizer Nozzles



Typical Application:

- Excellent for application of liquid fertilizer.

Features:

- Creates seven identical fluid streams of equal velocity and capacity.
- Excellent spray distribution quality.
- Removable metering orifice for easy cleaning.
- Offered in a variety of sizes for a wide range of application rates.
- VisiFlo® color-coding for easy capacity identification.
- All acetel construction for excellent chemical resistance.
- Recommended operating pressure: 20–60 PSI (1.5–4 bar).

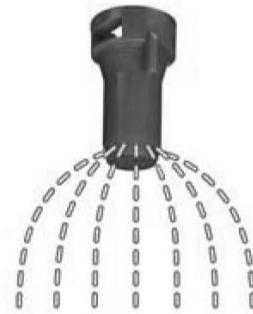

50854-NYB
Extension Adapter



Nozzle Model	PSI	CAPACITY ONE NOZZLE IN GPM	GPA $\triangle 20'$											
			3 MPH	4 MPH	5 MPH	6 MPH	8 MPH	10 MPH	12 MPH	14 MPH	16 MPH	18 MPH	20 MPH	
SJ7-015-VP (100)	20	0.10	9.9	7.4	5.9	5.0	3.7	3.0	2.5	2.1	1.9	1.7	1.5	
	30	0.12	11.9	8.9	7.1	5.9	4.5	3.6	3.0	2.5	2.2	2.0	1.8	
	40	0.15	14.9	11.1	8.9	7.4	5.6	4.5	3.7	3.2	2.8	2.5	2.2	
	50	0.16	15.8	11.9	9.5	7.9	5.9	4.8	4.0	3.4	3.0	2.6	2.4	
	60	0.18	17.8	13.4	10.7	8.9	6.7	5.3	4.5	3.8	3.3	3.0	2.7	
SJ7-02-VP (50)	20	0.14	13.9	10.4	8.3	6.9	5.2	4.2	3.5	3.0	2.6	2.3	2.1	
	30	0.17	16.8	12.6	10.1	8.4	6.3	5.0	4.2	3.6	3.2	2.8	2.5	
	40	0.20	19.8	14.9	11.9	9.9	7.4	5.9	5.0	4.2	3.7	3.3	3.0	
	50	0.23	23	17.1	13.7	11.4	8.5	6.8	5.7	4.9	4.3	3.8	3.4	
	60	0.25	25	18.6	14.9	12.4	9.3	7.4	6.2	5.3	4.6	4.1	3.7	
SJ7-03-VP (50)	20	0.22	22	16.3	13.1	10.9	8.2	6.5	5.4	4.7	4.1	3.6	3.3	
	30	0.27	27	20	16.0	13.4	10.0	8.0	6.7	5.7	5.0	4.5	4.0	
	40	0.30	30	22	17.8	14.9	11.1	8.9	7.4	6.4	5.6	5.0	4.5	
	50	0.33	33	25	19.6	16.3	12.3	9.8	8.2	7.0	6.1	5.4	4.9	
	60	0.35	35	26	21	17.3	13.0	10.4	8.7	7.4	6.5	5.8	5.2	
SJ7-04-VP (50)	20	0.30	30	22	17.8	14.9	11.1	8.9	7.4	6.4	5.6	5.0	4.5	
	30	0.35	35	26	21	17.3	13.0	10.4	8.7	7.4	6.5	5.8	5.2	
	40	0.40	40	30	24	19.8	14.9	11.9	9.9	8.5	7.4	6.6	5.9	
	50	0.43	43	32	26	21	16.0	12.8	10.6	9.1	8.0	7.1	6.4	
	60	0.46	46	34	27	23	17.1	13.7	11.4	9.8	8.5	7.6	6.8	
SJ7-05-VP (50)	20	0.38	38	28	23	18.8	14.1	11.3	9.4	8.1	7.1	6.3	5.6	
	30	0.45	45	33	27	22	16.7	13.4	11.1	9.5	8.4	7.4	6.7	
	40	0.50	50	37	30	25	18.6	14.9	12.4	10.6	9.3	8.3	7.4	
	50	0.54	53	40	32	27	20	16.0	13.4	11.5	10.0	8.9	8.0	
	60	0.58	57	43	34	29	22	17.2	14.4	12.3	10.8	9.6	8.6	
SJ7-06-VP (50)	20	0.45	45	33	27	22	16.7	13.4	11.1	9.5	8.4	7.4	6.7	
	30	0.54	53	40	32	27	20	16.0	13.4	11.5	10.0	8.9	8.0	
	40	0.60	59	45	36	30	22	17.8	14.9	12.7	11.1	9.9	8.9	
	50	0.65	64	48	39	32	24	19.3	16.1	13.8	12.1	10.7	9.7	
	60	0.70	69	52	42	35	26	21	17.3	14.9	13.0	11.6	10.4	
SJ7-08-VP	20	0.57	56	42	34	28	21	16.9	14.1	12.1	10.6	9.4	8.5	
	30	0.72	71	53	43	36	27	21	17.8	15.3	13.4	11.9	10.7	
	40	0.80	79	59	48	40	30	24	19.8	17.0	14.9	13.2	11.9	
	50	0.87	86	65	52	43	32	26	22	18.5	16.1	14.4	12.9	
	60	0.93	92	69	55	46	35	28	23	19.7	17.3	15.3	13.8	
SJ7-10-VP	20	0.71	70	53	42	35	26	21	17.6	15.1	13.2	11.7	10.5	
	30	0.90	89	67	53	45	33	27	22	19.1	16.7	14.9	13.4	
	40	1.00	99	74	59	50	37	30	25	21	18.6	16.5	14.9	
	50	1.09	108	81	65	54	40	32	27	23	20	18.0	16.2	
	60	1.16	115	86	69	57	43	34	29	25	22	19.1	17.2	
SJ7-15-VP	20	1.03	102	76	61	51	38	31	25	22	19.1	17.0	15.3	
	30	1.29	128	96	77	64	48	38	32	27	24	21	19.2	
	40	1.50	149	111	89	74	56	45	37	32	28	25	22	
	50	1.64	162	122	97	81	61	49	41	35	30	27	24	
	60	1.76	174	131	105	87	65	52	44	37	33	29	26	

Note: Always double check your application rates. Tabulations are based on spraying water at 70°F (21°C).



TeeJet® Flow Regulators

Flow Regulators are usually mounted behind cultivator shanks for the subsurface application of liquid fertilizers and soil fumigants. They are also used for above-ground streaming applications.

Typical Assembly



Note: Always insert Orifice Plate with side marked with number facing the outlet.

MATERIAL: Stainless Steel

To determine the orifice plates you need, use the following equations:

$$\text{GPM (Per Nozzle)} = \frac{\text{GPA} \times \text{MPH} \times \text{W}}{5,940}$$

$$\text{GPA} = \frac{5,940 \times \text{GPM (Per Nozzle)}}{\text{MPH} \times \text{W}}$$

- W = Nozzle spacing (in inches) for broadcast spraying.
- = Spray width (in inches) for single nozzle, band spraying or boomless spraying.
- = Row spacing (in inches) divided by the number of nozzles per row for directed spraying.

Tabulated flow rates are for spraying water into air atmospheric pressure. If your application creates backpressure, or if spraying into a liquid, measure and calibrate to ensure proper application rates.

Orifice Size	GPM						
	5 PSI	10 PSI	20 PSI	30 PSI	40 PSI	50 PSI	60 PSI
CP4916-008	0.003	0.004	0.006	0.007	0.008	0.009	0.010
CP4916-10	0.005	0.007	0.009	0.011	0.013	0.015	0.016
CP4916-12	0.007	0.010	0.013	0.016	0.019	0.021	0.023
CP4916-14	0.009	0.013	0.018	0.022	0.025	0.028	0.031
CP4916-15	0.010	0.015	0.021	0.025	0.029	0.032	0.036
CP4916-16	0.012	0.017	0.023	0.029	0.033	0.037	0.040
CP4916-18	0.015	0.021	0.030	0.036	0.042	0.047	0.051
CP4916-20	0.018	0.026	0.037	0.045	0.052	0.058	0.064
CP4916-22	0.022	0.031	0.043	0.053	0.061	0.068	0.075
CP4916-24	0.026	0.037	0.052	0.064	0.074	0.083	0.091
CP4916-25	0.028	0.040	0.056	0.068	0.079	0.088	0.097
CP4916-26	0.030	0.043	0.061	0.074	0.086	0.096	0.105
CP4916-27	0.032	0.046	0.064	0.079	0.091	0.102	0.111
CP4916-28	0.035	0.049	0.069	0.085	0.098	0.110	0.120
CP4916-29	0.038	0.054	0.076	0.094	0.108	0.121	0.132
CP4916-30	0.040	0.057	0.081	0.099	0.114	0.127	0.140
CP4916-31	0.043	0.062	0.087	0.107	0.123	0.138	0.151
CP4916-32	0.048	0.068	0.095	0.117	0.135	0.151	0.165
CP4916-34	0.052	0.074	0.104	0.127	0.147	0.164	0.180
CP4916-35	0.056	0.079	0.111	0.136	0.157	0.176	0.192
CP4916-37	0.061	0.086	0.122	0.149	0.172	0.192	0.211
CP4916-39	0.068	0.096	0.135	0.165	0.191	0.214	0.234
CP4916-40	0.072	0.102	0.144	0.177	0.204	0.228	0.250
CP4916-41	0.075	0.106	0.149	0.183	0.211	0.236	0.258
CP4916-43	0.082	0.116	0.163	0.200	0.231	0.258	0.283
CP4916-45	0.088	0.125	0.177	0.217	0.250	0.280	0.306
CP4916-46	0.095	0.135	0.191	0.234	0.270	0.302	0.331

Orifice Size	GPM						
	5 PSI	10 PSI	20 PSI	30 PSI	40 PSI	50 PSI	60 PSI
CP4916-47	0.097	0.138	0.194	0.238	0.275	0.307	0.337
CP4916-48	0.101	0.143	0.202	0.248	0.286	0.320	0.350
CP4916-49	0.104	0.148	0.209	0.255	0.295	0.330	0.361
CP4916-51	0.116	0.165	0.233	0.285	0.329	0.368	0.403
CP4916-52	0.118	0.168	0.237	0.290	0.335	0.375	0.410
CP4916-54	0.127	0.180	0.255	0.312	0.360	0.402	0.441
CP4916-55	0.133	0.189	0.267	0.326	0.377	0.421	0.462
CP4916-57	0.141	0.200	0.283	0.346	0.400	0.447	0.490
CP4916-59	0.153	0.217	0.306	0.375	0.433	0.484	0.530
CP4916-61	0.165	0.233	0.330	0.404	0.466	0.521	0.571
CP4916-63	0.174	0.246	0.347	0.425	0.491	0.549	0.601
CP4916-65	0.185	0.261	0.369	0.452	0.522	0.584	0.639
CP4916-67	0.196	0.278	0.392	0.481	0.555	0.621	0.680
CP4916-68	0.203	0.287	0.405	0.496	0.573	0.641	0.702
CP4916-70	0.216	0.306	0.433	0.530	0.612	0.684	0.750
CP4916-72	0.226	0.320	0.453	0.554	0.640	0.716	0.784
CP4916-73	0.233	0.330	0.467	0.572	0.660	0.738	0.808
CP4916-75	0.245	0.347	0.491	0.601	0.694	0.776	0.850
CP4916-78	0.272	0.385	0.544	0.667	0.770	0.861	0.943
CP4916-80	0.280	0.397	0.561	0.687	0.793	0.887	0.971
CP4916-81	0.290	0.411	0.581	0.711	0.821	0.918	1.01
CP4916-83	0.317	0.449	0.634	0.777	0.897	1.00	1.10
CP4916-86	0.332	0.470	0.664	0.813	0.939	1.05	1.15
CP4916-89	0.346	0.490	0.693	0.849	0.980	1.10	1.20
CP4916-91	0.369	0.523	0.739	0.905	1.05	1.17	1.28
CP4916-93	0.387	0.547	0.774	0.947	1.09	1.22	1.34
CP4916-95	0.404	0.572	0.808	0.990	1.14	1.28	1.40

Orifice Size	GPM						
	5 PSI	10 PSI	20 PSI	30 PSI	40 PSI	50 PSI	60 PSI
CP4916-98	0.442	0.625	0.884	1.08	1.25	1.40	1.53
CP4916-103	0.461	0.653	0.923	1.13	1.31	1.46	1.60
CP4916-107	0.518	0.733	1.04	1.27	1.47	1.64	1.79
CP4916-110	0.548	0.775	1.10	1.34	1.55	1.73	1.90
CP4916-115	0.605	0.855	1.21	1.48	1.71	1.91	2.09
CP4916-120	0.629	0.890	1.26	1.54	1.78	1.99	2.18
CP4916-125	0.693	0.980	1.39	1.70	1.96	2.19	2.40
CP4916-128	0.721	1.02	1.44	1.77	2.04	2.28	2.50
CP4916-132	0.774	1.10	1.55	1.90	2.19	2.45	2.68
CP4916-136	0.840	1.19	1.68	2.06	2.38	2.66	2.91
CP4916-140	0.894	1.27	1.79	2.19	2.53	2.83	3.10
CP4916-144	0.926	1.31	1.85	2.27	2.62	2.93	3.21
CP4916-147	0.953	1.35	1.91	2.33	2.70	3.01	3.30
CP4916-151	1.04	1.47	2.08	2.55	2.94	3.29	3.60
CP4916-156	1.10	1.55	2.20	2.69	3.11	3.47	3.80
CP4916-161	1.15	1.63	2.31	2.83	3.27	3.65	4.00
CP4916-166	1.21	1.72	2.43	2.97	3.43	3.84	4.20
CP4916-170	1.30	1.84	2.61	3.19	3.69	4.12	4.51
CP4916-172	1.36	1.92	2.71	3.32	3.84	4.29	4.70
CP4916-177	1.41	2.00	2.83	3.46	4.00	4.47	4.90
CP4916-182	1.47	2.08	2.95	3.61	4.17	4.66	5.10
CP4916-187	1.56	2.21	3.12	3.82	4.41	4.93	5.40
CP4916-196	1.73	2.45	3.46	4.24	4.90	5.47	6.00
CP4916-205	1.88	2.65	3.75	4.59	5.31	5.93	6.50
CP4916-218	2.11	2.98	4.21	5.16	5.96	6.66	7.30
CP4916-234	2.45	3.47	4.91	6.01	6.94	7.76	8.50
CP4916-250	2.83	4.00	5.66	6.93	8.00	8.94	9.80

Note: Always double check your application rates. Tabulations are based on spraying water at 70°F (21°C).

FERTILIZER NOZZLES

StreamJet® Solid Stream Spray Nozzles



Stainless Steel for Banding Fertilizers

- Permits banding fluids at high rig speeds.
- Large orifices with no internal obstructions permit non-clogging suspension applications.
- Lower drift potential.

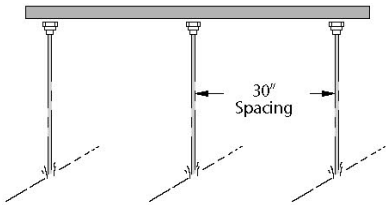

Nozzle Model	PSI	CAPACITY ONE NOZZLE IN GPM	GPA 30°								
			4 MPH	6 MPH	8 MPH	10 MPH	12 MPH	14 MPH	16 MPH	18 MPH	20 MPH
H1/4U-SS0004 TP0004-SS	10	0.20	9.9	6.6	5.0	4.0	3.3	2.8	2.5	2.2	2.0
	20	0.28	13.9	9.2	6.9	5.5	4.6	4.0	3.5	3.1	2.8
	30	0.35	17.3	11.6	8.7	6.9	5.8	5.0	4.3	3.9	3.5
H1/4U-SS0006 TP0006-SS	10	0.30	14.9	9.9	7.4	5.9	5.0	4.2	3.7	3.3	3.0
	20	0.42	21	13.9	10.4	8.3	6.9	5.9	5.2	4.6	4.2
	30	0.52	26	17.2	12.9	10.3	8.6	7.4	6.4	5.7	5.1
H1/4U-SS0008 TP0008-SS	10	0.40	19.8	13.2	9.9	7.9	6.6	5.7	5.0	4.4	4.0
	20	0.57	28	18.8	14.1	11.3	9.4	8.1	7.1	6.3	5.6
	30	0.69	34	23	17.1	13.7	11.4	9.8	8.5	7.6	6.8
H1/4U-SS0010 TP0010-SS	10	0.50	25	16.5	12.4	9.9	8.3	7.1	6.2	5.5	5.0
	20	0.71	35	23	17.6	14.1	11.7	10.0	8.8	7.8	7.0
	30	0.87	43	29	22	17.2	14.4	12.3	10.8	9.6	8.6
H1/4U-SS0015 TP0015-SS	10	0.75	37	25	19	14.9	12.4	10.6	9.3	8.3	7.4
	20	1.06	52	35	26	21	17.5	15.0	13.1	11.7	10.5
	30	1.30	64	43	32	26	21	18.4	16.1	14.3	12.9
H1/4U-SS0020 TP0020-SS	10	1.00	50	33	25	19.8	16.5	14.1	12.4	11.0	9.9
	20	1.41	70	47	35	28	23	19.9	17.4	15.5	14.0
	30	1.73	86	57	43	34	29	24	21	19.0	17.1
H1/4U-SS0030 TP0030-SS	10	1.50	74	50	37	30	25	21	18.6	16.5	14.9
	20	2.12	105	70	52	42	35	30	26	23	21
	30	2.60	129	86	64	51	43	37	32	29	26
H1/4U-SS0040 TP0040-SS	10	2.00	99	66	50	40	33	28	25	22	20
	20	2.83	140	93	70	56	47	40	35	31	28
	30	3.46	171	114	86	69	57	49	43	38	34
H1/4U-SS0050	10	2.50	124	83	62	50	41	35	31	28	25
	20	3.54	175	117	88	70	58	50	44	39	35
	30	4.33	214	143	107	86	71	61	54	48	43
H1/4U-SS0060	10	3.00	149	99	74	59	50	42	37	33	30
	20	4.24	210	140	105	84	70	60	52	47	42
	30	5.20	257	172	129	103	86	74	64	57	51

Note: Always double check your application rates. Tabulations are based on spraying water at 70°F (21°C).



BOOM COMPONENTS



Quick TeeJet® Multiple Nozzle Body Assemblies for Dry Booms

QJ350 Compact Nozzle Body for Dry Booms

- Compact design means easier mounting and less interference with boom structure.
- Available with 3 or 5 spray positions for easy change of spray tips or quick boom flushing.
- Shutoff between each spray position.
- Automatic spray alignment using flat fan spray tips.
- Positive indexing keeps the nozzle you select firmly in place.
- Maximum operating pressure 300 PSI (20 bar).
- Available in 1/2", 3/4" or 1" single or double hose shanks.
- Includes ChemSaver® diaphragm check valve for drip-free shutoff. Standard diaphragm opens at 10 PSI (0.7 bar).
- 1.80 GPM (6.80 l/min) with 5 PSI (0.34 bar) pressure drop.



- Molded hex socket in upper clamp for attaching to flat surfaces.
- Hinged upper clamp reduces assembly time and fits inside common boom channels.

QJ353

PART NUMBER		NUMBER OF SPRAY OUTLETS	TO FIT HOSE I.D.
SINGLE	DOUBLE		
SPQ353112	SPQ353212	3	1/2"
SPQ353134	SPQ353234	3	3/4"
SPQ3531100	SPQ3532100	3	1"



QJ353

QJ355

PART NUMBER		NUMBER OF SPRAY OUTLETS	TO FIT HOSE I.D.
SINGLE	DOUBLE		
SPQ355112	SPQ355212	5	1/2"
SPQ355134	SPQ355234	5	3/4"
SPQ3551100	SPQ3552100	5	1"



QJ355



TeeJet® Vari-Spacing Clamps for Use on Dry Boom Quick TeeJet Bodies

PART NUMBER (PLATED STEEL)	TO FIT
SPQ12VS	1/2" Pipe (3/8" & 7/8" O.D. Tubings)
SPQ34VS	3/4" Pipe (1" & 1 1/8" O.D. Tubings)
SPQ1VS	1" Pipe (1 1/8", 1 1/4" & 1 3/8" O.D. Tubings)
SPQ114VS	1 1/4" Pipe (1 3/8" & 1 1/2" O.D. Tubings)

PART NUMBER	TO FIT
SPQ34SQVS	3/4" Square Tubing
SPQ1SQVS	1" Square Tubing
SPQ114SQVS	1 1/4" Square Tubing
SPQ112SQVS	1 1/2" Square Tubing



QJ111



QJ111SQ

Quick TeeJet® Multiple Nozzle Body Assemblies for Dry Booms



QJ360C Nozzle Body Series for Dry Booms

- Available with either 3, 4 or 5 spray positions for easy change of spray tips or quick boom flushing.
- Positive shutoff between each spray position.
- Automatic spray alignment using flat fan spray tips.
- Maximum operating pressure of 300 PSI (20 bar).
- Available in ½", ¾" or 1" single or double hose shanks.
- Includes ChemSaver® diaphragm check valve for drip-free shutoff. Standard diaphragm opens at 10 PSI (0.7 bar).
- Standard EPDM diaphragm with Viton® available as an option.
- Also available with optional 56720 ChemSaver air shutoff valve, see page 65 for additional information.
- Durable design mounts body high on boom structure for maximum protection.
- 2.25 GPM (8.5 l/min) with 5 PSI (0.34 bar) pressure drop.



- Mounts to a ⅜" (9.5 mm) hole drilled in pipe or tubing.
- Molded hex socket in upper clamp for attaching to flat surfaces.
- Hinged upper clamp reduces assembly time and fits inside common boom channels.

QJ363C

PART NUMBER		NUMBER OF SPRAY OUTLETS	TO FIT HOSE I.D.
SINGLE	DOUBLE		
SPQ363112	SPQ363212	3	½"
SPQ363134	SPQ363234	3	¾"
SPQ3631100	SPQ3632100	3	1"



QJ363C

QJ364C

PART NUMBER		NUMBER OF SPRAY OUTLETS	TO FIT HOSE I.D.
SINGLE	DOUBLE		
SPQ364112	SPQ364212	4	½"
SPQ364134	SPQ364234	4	¾"
SPQ3641100	SPQ3642100	4	1"



QJ364C

QJ365C

PART NUMBER		NUMBER OF SPRAY OUTLETS	TO FIT HOSE I.D.
SINGLE	DOUBLE		
SPQ365112	SPQ365212	5	½"
SPQ365134	SPQ365234	5	¾"
SPQ3651100	SPQ3652100	5	1"



QJ365C



Quick TeeJet® Multiple Nozzle Body Assemblies

Triple Nozzle Body

- Designed to greatly simplify changing spray tips in the field.
- Provides three spray positions for easy change of spray tips or quick boom flushing.
- Positive shutoff between each spray position.
- Includes ChemSaver® diaphragm check valve for drip-free shutoff. Opens at 10 PSI (0.7 bar).
- Standard EPDM diaphragm with Viton® available as an option.

- Can be used with all Quick TeeJet caps.
- Nylon body.
- Maximum operating pressure of 125 PSI (9 bar).



24230A

PART NUMBER		TO FIT HOSE
SINGLE	DOUBLE	
SP24230112	SP24230212	1/2"
SP24230134	SP24230234	3/4"



Quick TeeJet® Multiple Nozzle Body Assemblies with Fertilizer Outlets for Dry Booms

Features:

- Single fertilizer nozzle outlet with shutoff cap and either 3, 4, or 5 spray positions for easy change of spray tips or quick boom flushing.
 - Positive shutoff between each position.
 - Automatic self-alignment with flat fan spray patterns.
 - Flow rate: pressure drop of 5 PSI (0.34 bar) for 2.25 GPM (8.5 l/min) through turret and 3.4 GPM (12.9 l/min) through fertilizer outlet.
 - Maximum pressure of 300 PSI (20 bar).
 - Available in 1" single or double hose shanks.
 - Includes ChemSaver diaphragm check valve for drip-free shutoff. Standard diaphragm opens at 10 PSI (0.7 bar).
-
- Standard O-rings and diaphragm made of EPDM and Buna with Viton optional.

- Molded hex socket in the upper clamp for attaching to flat surfaces (does not use dry boom clamp).
- Also available with optional 56720 ChemSaver air shutoff valve, see page 65 for additional information.
- Hinged upper clamp reduces assembly time and fits inside common boom channels.



QJ363F



QJ364F



QJ365F

PART NUMBER		NUMBER OF SPRAY OUTLETS	TO FIT HOSE I.D.
SINGLE	DOUBLE		
SPQ363F1100	SPQ363F2100	3 + 1	1"
SPQ364F1100	SPQ364F2100	4 + 1	
SPQ365F1100	SPQ365F1100	5 + 1	

Quick TeeJet® Single Nozzle Bodies for Dry Booms



QJ100 Series Quick TeeJet Nozzle Body

- Hose barb sizes for 3/8", 1/2" or 3/4" I.D. hose.
- Maximum operating pressure of 125 PSI (9 bar).

	PART NUMBER SINGLE	TO FIT HOSE I.D.
	SPQ18635	3/8"
SPQ18638	1/2"	
SPQ18719	3/4"	

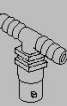
	PART NUMBER DOUBLE	TO FIT HOSE I.D.
	SPQ18636	3/8"
SPQ18639	1/2"	
SPQ18720	3/4"	

	PART NUMBER TRIPLE	TO FIT HOSE I.D.
	SPQ18637	3/8"
SPQ18640	1/2"	
SPQ18721	3/4"	

QJ39685 Series Quick TeeJet Nozzle Body

Features:

- Use with Quick TeeJet caps.
- Hose shanks available in double or single (left or right) for 1/2" hose I.D.
- TeeJet ChemSaver drip-free shutoff.



QJ200 Series Diaphragm Check Valve Quick TeeJet Nozzle Assemblies

- Available with single, double or triple hose shanks for 3/8", 1/2" and 3/4" I.D. hose.
- Drip-free shutoff with TeeJet ChemSaver®. Opens at 10 PSI (0.7 bar). Standard diaphragm is EPDM with Viton® optional.
- Maximum operating pressure of 125 PSI (9 bar).

	PART NUMBER SINGLE	TO FIT HOSE I.D.
	SPQ1934938	3/8"
SPQ1934850	1/2"	
SPQ1934975	3/4"	

	PART NUMBER DOUBLE	TO FIT HOSE I.D.
	SPQ1935038	3/8"
SPQ1935050	1/2"	
SPQ1935075	3/4"	

	PART NUMBER TRIPLE	TO FIT HOSE I.D.
	SPQ1935138	3/8"
SPQ1935150	1/2"	
SPQ1935175	3/4"	

- Made of corrosion-resistant materials.
- Maximum operating pressure of 300 PSI (20 bar).



QJ300 Series Diaphragm Check Valve Quick TeeJet Nozzle Assemblies

- Low-profile design allows maximum protection against damage.
- Available with single and double hose shanks for 3/8", 1/2" and 3/4" I.D. hose.
- Drip-free shutoff with TeeJet ChemSaver®. Opens at 10 PSI (0.7 bar). Standard diaphragm is EPDM with Viton optional.
- Maximum operating pressure of 300 PSI (20 bar).

QJ300 Series is also available in polypropylene. Maximum operating pressure is 150 PSI (10 bar).

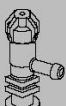
	PART NUMBER SINGLE	TO FIT HOSE I.D.
	SPQ2225138	3/8"
SPQ2225150	1/2"	
SPQ2225175	3/4"	

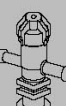
	PART NUMBER DOUBLE	TO FIT HOSE I.D.
	SPQ2225238	3/8"
SPQ2225250	1/2"	
SPQ2225275	3/4"	

Note: See page 54 for vari-spacing clamps. See page 63 for Quick TeeJet caps.

- QJ39684 uses Nylon nut instead of brass nut.

Note: Support is normally supplied by the customer. TeeJet vari-spacing clamps AA111-* can be used.





Quick TeeJet® Multiple Nozzle Bodies for Wet Booms

QJ350 Compact Nozzle Body for Wet Booms

- Compact design means easier mounting and less interference with boom structure.
- Available with 3 or 5 spray positions for easy change of spray tips or quick boom flushing.
- Shutoff between each spray position.
- Positive indexing keeps the nozzle you select firmly in place.
- Automatic spray alignment using flat fan spray tips.
- Maximum operating pressure of 300 PSI (20 bar).
- Available to fit 20 mm tubing, 1/2", 3/4" and 1" pipe.
- Includes ChemSaver® diaphragm check valve for drip-free shutoff. Standard diaphragm opens at 10 PSI (0.7 bar).
- 1.80 GPM (6.80 l/min) with 5 PSI (0.34 bar) pressure drop.
- Molded hex socket in upper clamp for attaching to flat surfaces.
- Hinged upper clamp reduces assembly time and fits inside common boom channels.



PART NUMBER	NUMBER OF SPRAY OUTLETS	TO CLAMP ON	PART NUMBER	NUMBER OF SPRAY OUTLETS	TO CLAMP ON
SPQ35320M	3	20 mm Tubing	SPQ35520M	5	20 mm Tubing
SPQ35312WB	3	1/2" Pipe	SPQ35512WB	5	1/2" Pipe
SPQ35334WB	3	3/4" Pipe	SPQ35534WB	5	3/4" Pipe
SPQ3531WB	3	1" Pipe	SPQ3551WB	5	1" Pipe

Quick TeeJet® Multiple Nozzle Bodies for Wet Booms



QJ360C Nozzle Body Series for Wet Booms

- Available with either 3, 4 or 5 spray positions for easy change of spray tips or quick boom flushing.
- Positive shutoff between each position.
- Automatic spray alignment using flat fan spray tips.
- Maximum operating pressure of 300 PSI (20 bar).
- Available in 20 mm, 25 mm, ½", ¾" or 1" pipe connections.
- Includes ChemSaver® diaphragm check valve for drip-free shutoff. Standard diaphragm opens at 10 PSI (0.7 bar).



- Standard EPDM diaphragm with Viton® available as an option.
- Also available with optional 56720 ChemSaver air shutoff valve
- 2.25 GPM (8.5 l/min) with 5 PSI (0.34 bar) pressure drop.
- Mounts to a ⅜" (9.5 mm) hole drilled in pipe or tubing.
- Molded hex socket in upper clamp for attaching to flat surfaces.
- Hinged upper clamp reduces assembly time and fits inside common boom channels.

QJ360E Nozzle Body Series for Wet Booms

- Available to fit 20 mm O.D. tubing only.
- Flow rate is 1.5 GPM (5.7 l/min) with a 5 PSI (0.35 bar) pressure drop.
- Reduced internal cavity to increase ChemSaver shut-off speed.
- Notched inlet tube allows for more complete boom drainage and reduces sediment buildup.



QJ363C
QJ363E



QJ364C
QJ364E



QJ365C
QJ365E

PART NUMBER	NUMBER OF SPRAY OUTLETS	TO CLAMP ON
SPQ36320M	3	20 mm Tubing
SPQ36325M	3	25 mm Tubing
SPQ36312WB	3	½" Pipe
SPQ36334WB	3	¾" Pipe
SPQ3631WB	3	1" Pipe

PART NUMBER	NUMBER OF SPRAY OUTLETS	TO CLAMP ON
SPQ36420M	4	20 mm Tubing
SPQ36425M	4	25 mm Tubing
SPQ36412WB	4	½" Pipe
SPQ36434WB	4	¾" Pipe
SPQ3641WB	4	1" Pipe

PART NUMBER	NUMBER OF SPRAY OUTLETS	TO CLAMP ON
SPQ36520M	5	20 mm Tubing
SPQ36525M	5	25 mm Tubing
SPQ36512WB	5	½" Pipe
SPQ36534WB	5	¾" Pipe
SPQ3651WB	5	1" Pipe

Quick TeeJet® Multiple Nozzle Bodies with Fertilizer Outlets for Wet Booms

Features:

- Single fertilizer nozzle outlet with shutoff cap and either 3, 4 or 5 spray positions for easy change of spray tips or quick boom flushing.
- Positive shutoff between each position.
- Automatic self-alignment with flat fan spray patterns.
- Flow rate: 2.25 GPM (8.5 l/min) with 5 PSI (0.34 bar) pressure drop through turret and 3.4 GPM (12.9 l/min) through fertilizer outlet.
- Maximum pressure of 300 PSI (20 bar).
- Available in 1" pipe connections and mounts with a 3/8" (9.5 mm) hole drilled in pipe or tubing.
- Includes ChemSaver® diaphragm check valve for drip-free shutoff. Standard diaphragm opens at 10 PSI (0.7 bar).
- Standard O-rings and diaphragm made of EPDM and Buna with Viton® optional.
- Also available with optional 56720 ChemSaver air shutoff valve.
- Molded hex socket in the upper clamp for attaching to flat surfaces.
- Hinged upper clamp reduces assembly time and fits inside common boom channels.



PART NUMBER	NUMBER OF SPRAY OUTLETS	TO CLAMP ON
SPQ363F1WB	3 + 1	1" Pipe
SPQ364F1WB	4 + 1	1" Pipe
SPQ365F1WB	5 + 1	1" Pipe





Type 24216A-NYB

- Can be mounted to 20 mm, ½", ¾" or 1" pipe or equivalent size tubing.
- Provides three spray positions for easy change of spray tips.
- Shutoff position provided between each spray position.
- Features ChemSaver® drip-free shutoff. Requires 10 PSI (0.7 bar) at the nozzle to open check valve.
- Standard diaphragm of EPDM with optional Viton® available.

- Maximum operating pressure of 150 PSI (10 bar).
- ½" and ¾" sizes include mounting hole in upper clamp subassembly for attachment to flat surfaces.
- Mounts to a ⅜" (9.5 mm) hole drilled in pipe or tubing.

PART NUMBER	TO CLAMP ON
SP24216-20	20 mm Tubing
SP24216-12	½" Pipe
SP24216-34	¾" Pipe
SP24216-1	1" Pipe



Type QJ22187-NYB

- Can be mounted to ½", ¾" or 1" pipe or equivalent size tubing.
- ½" and ¾" sizes include a mounting hole in clamp subassembly for mounting to flat surfaces.
- Allows side mounting to flat surface for protection of nozzle body.
- Features ChemSaver drip-free shutoff. Requires 10 PSI (0.7 bar) at the nozzle to open check valve.
- Standard diaphragm of EPDM with optional Viton available.

- Mounts to a ⅜" (9.5 mm) hole drilled in pipe or tubing.
- Maximum operating pressure of 300 PSI (20 bar).

PART NUMBER	TO CLAMP ON
SPQ22187-12	½" Pipe
SPQ22187-34	¾" Pipe
SPQ22187-1	1" Pipe



Type QJ17560A-NYB

- Can be mounted to 20 mm, 25 mm, ½", ¾" or 1" pipe or equivalent size tubing.
- Features ChemSaver drip-free shutoff. Requires 10 PSI (0.7 bar) at the nozzle to open check valve.
- Standard diaphragm of EPDM with optional Viton available.
- Mounts to a ⅜" (9.5 mm) hole drilled in pipe or tubing.
- Maximum operating pressure of 300 PSI (20 bar).

- ½" and ¾" sizes include a mounting hole in upper clamp subassembly for mounting to flat surfaces.

PART NUMBER	TO CLAMP ON
SPQ1756020	20 mm Tubing
SPQ1756025	25 mm Tubing
SPQ17560-12	½" Pipe
SPQ17560-34	¾" Pipe
SPQ17560-1	1" Pipe



Type QJ7421-NYB

- Can be mounted to ½", ¾" or 1" pipe or equivalent size tubing.
- Mounts to a ⅜" (9.5 mm) hole drilled in pipe or tubing.
- Maximum operating pressure of 300 PSI (20 bar).

- ½" and ¾" sizes include a mounting hole in upper clamp subassembly for mounting to flat surfaces.

PART NUMBER	TO CLAMP ON
SPQ7421-12	½" Pipe
SPQ7421-34	¾" Pipe
SPQ7421-1	1" Pipe



Quick TeeJet Adapters and Accessories

QJ1/4T-NYB & QJT-NYB

- QJ1/4T-NYB allows use of Quick TeeJet system with 1/4" NPT
- QJT-NYB permits use of Quick TeeJet system with standard 1/4"-16 TeeJet thread.
- Maximum operating pressure of 300 PSI (20 bar).

PART NUMBER	TO FIT
SPQ14T-NYB	1/4" (F) thread



QJ90-2-NYR

- Fits standard Quick TeeJet bodies.
- Made of Nylon with CP19438-EPR gasket (included).
- Use with Quick TeeJet cap and gasket for automatic alignment when using flat fan spray tips.
- 90° included angle between outlets. When used with standard flat fan tips produces a twin type spray pattern for improved coverage and canopy penetration.

PART NUMBER	TO FIT
SPQJ90-2	Quick TeeJet

QJ1/4TT-NYB

- Allows use of Quick TeeJet system with 1/4" NPT female connections.
- Maximum operating pressure of 300 PSI (20 bar).

PART NUMBER	TO FIT
SPQ18041	1/4" (M) thread



22674-1/4-NYB

- Allows use of Quick TeeJet system with 1/4" NPT female connections.

PART NUMBER	TO FIT
SP22674	1/4" (M) thread

QJT8360-NYB, QJP19011-NYB, QJ8360-NYB

- Retrofits to a Quick TeeJet system.
- Features ChemSaver™ no-drip shutoff. Requires 10 PSI (0.7 bar) at the nozzle to open check valve.
- Standard diaphragm of EPDM with optional Viton™ available upon request.
- Maximum operating pressure of 300 PSI (20 bar).

PART NUMBER	TO FIT
SPQ8360	1/4" (M) thread
SPQJT8360*	1/4" TeeJet thread



QJ8355-NYB

- Allows use of Quick TeeJet system with 1/8" and 1/4" NPT female connections.
- Side mounting provides protection of the nozzle body.
- Features ChemSaver no-drip shutoff. Requires 10 PSI (0.7 bar) at the nozzle to open check valve.
- Standard diaphragm of EPDM with optional Viton available upon request.
- Maximum operating pressure of 300 PSI (20 bar).

PART NUMBER	TO FIT
SPQ8355-18	1/8" (F)
SPQ8355-14	1/4" (F)

* Available in a 2# cap version: SPQJT38622.



Quick TeeJet Caps for Hardi Nozzle Bodies

Color Code



Ordering Information

QUICK TEEJET CAPS	PART NUMBER	QUICK TEEJET CAP & SEAT GASKET SET	FOR USE WITH FLAT SPRAY TIPS 150 PSI (10 BAR) MAXIMUM PRESSURE				
			TJ TwinJet®	All TeeJet® & All U8 TeeJet®	SJ-3 StreamJet®	DGTwinJet®	Turbo TeeJet® Induction

Note: When using TeeJet tip strainer, use CP26227 gasket in place of CP23308 gasket.

Quick TeeJet® Caps



Color Code

1	2	3	4	5	6	7	8	††	10
Black	White	Red	Blue	Green	Yellow	Brown	Orange	Gray	Violet

Ordering Information

QUICK TEEJET CAPS	PART NUMBER		FOR USE WITH FLAT SPRAY TIP'S 300 PSI (20 BAR) MAXIMUM PRESSURE
	QUICK TEEJET CAP ONLY	QUICK TEEJET CAP & SEAT GASKET SET	
	SPQ25611-*		TeeJet Flat Spray Tips (Smaller Capacities) TP Standard -0067 Thru -08 XR -01 Thru -08 DG TeeJet® TT Turbo TwinJet® AKR TeeJet® DC TeeJet® -01 Thru -08
	SPQ25611-9		
	SPQ25609-*		TeeJet Flat Spray Tips (Larger Capacities) TP Standard -10 Thru -20 XR -10 Thru -15
	SPQ25597-*		TJ TwinJet® AI TeeJet® & AIUB TeeJet® SJ-3 StreamJet® DGTwinJet® Turbo TeeJet Induction®
	SPQ25595-*		TeeJet Flat Spray Tips (Smaller Capacities) Tips can be positioned in choice of two spray plane directions—parallel or perpendicular to wings of Quick TeeJet cap.
	SPQ25599-*		TK FloodJet® VisiFlo® Spray Tip TK-VS FloodJet® VisiFlo® Spray Tip Locating Nib
	SPQ25607-*		TK FloodJet® FL FullJet® TX ConeJet® TG Full Cone Hose Shank
	SPQ25607-9		
	SPQ25607-*		D-Disc Core Seal Core CP18999-EPR (EPDM standard) CP18999-VI (Viton® optional) Used with DC-Core Inserts and CP4916 Flow Regulators (Insert Core into Seat)
	—	SPQ4676-45	45° Quick TeeJet cap
	—	SPQ4676-90	90° Quick TeeJet cap
	SPQ26277-1		Ceramic Disc-Core D-Disc Core
	—	SPQ4676-18	Permits use of standard 1/8" and 1/4" nozzles. Can be used for mounting pressure gauge at the nozzle. See Data Sheet 20055 for more information.
	—	SPQ4676-14	
	—	SPQ19843	Provides shutoff at nozzle for quick spacing change or change in spray swath.

*Specify color code (see chart). Unless otherwise specified, a yellow (6) cap will be supplied. Violet (10) only available in CP25611 and CP25597 Nylon caps.

†These Quick TeeJet caps available only in black.

††Polypropylene Quick TeeJet caps available only in gray.

Quick TeeJet Cap

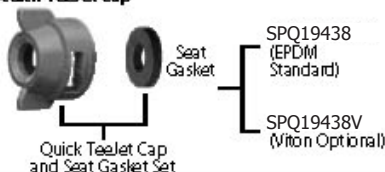

The Quick TeeJet caps are designed with grooves that fit locating lugs on the nozzle body. Caps are made of Nylon and are available for use with all TeeJet® spray tips. Maximum operating pressure of 300 PSI (20 bar).

TeeJet[®] Tip Strainers



MESH SIZE
16
24
50
80
100
200

TeeJet Strainers

Strainers protect spray tip orifices from clogging and damage. Stainless steel screens are available in 24, 50 and 200 mesh. 19845 tip strainers are available in 25 and 50 mesh only.

TEEJET STRAINER NUMBER	STRAINER BODY AND CAP MATERIAL	MESH SCREEN MATERIAL
SP5053-*	Brass	Stainless Steel
SP8079-*	Polypropylene	Stainless Steel
SP6051-*	Stainless Steel	Stainless Steel
SP19845-*	Polypropylene	Polypropylene

*Specify mesh size when ordering.

55215 Self-Retaining Tip Strainer

Features:

- For Use with Quick TeeJet[®] caps.
- Allows tip strainer to be easily removed from nozzle body for cleaning.
- 50 or 100 mesh color-coded strainer with optional EPDM or Viton[®] gasket.



STRAINER NUMBER	MESH
SP55215-50*	50
SP55215-100*	100

*Identify gasket material. Leave blank for EPDM, use 'V' for viton.

TeeJet Slotted Strainers

One-piece strainers for use with liquids containing suspended solids.



TEEJET STRAINER NUMBER	AVAILABLE MATERIAL	EQUIVALENT TO MESH SIZE
SP4514-10	Brass or Nylon	50
SP4514-20	Brass, Aluminum or Nylon	25
SP4514-32	Brass, Aluminum or Nylon	16

*A above numbers for brass. For Nylon add "NY". For aluminum add "AL".

4193A TeeJet Strainer and Check Valve

Minimizes nozzle dripping; fits all TeeJet nozzles. Ball check opens at 5 PSI (0.34 bar). Recommended for flow rates up to 0.8 GPM (3 l/min). 24, 50, 100 and 200 mesh screens. Not for use with AI or DG tips.

Not e: Use of these ball check valves results in a pressure drop of 5 PSI (0.34 bar) to 10 PSI (0.7 bar) depending on spring rating.



CHECK VALVE NUMBER	BODY AND CAP SCREEN MATERIAL	MESH SCREEN MATERIAL
SP4193-(mesh)	Brass	Stainless Steel
SP4193(mesh)SS	Stainless Steel	Stainless Steel
SP4193-(mesh)P	Polypropylene	Stainless Steel



TeeJet® ChemSaver® Diaphragm Check Valves

In this type of nozzle body, the diaphragm check valve is an integral part of the nozzle assembly. This design eliminates the pressure drop associated with ball-type check valves. The spring-backed diaphragm ensures dependable closure. Originally developed for use in aerial spraying, nozzle bodies of this design are now widely used wherever drip-free shutoff is required. For maximum operating pressures of 125 PSI (9 bar).

Typical Assembly

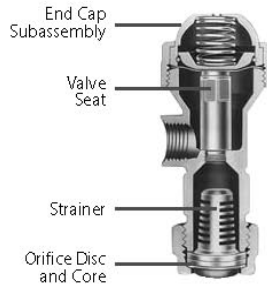

8355

Made of Nylon with Nylon/polypropylene end cap assembly. Check valve opens at 10 PSI (0.7 bar) pressure. Choice of 3/8" or 1/2" NPT (F) inlet connections. For flow rates up to 2.5 GPM (9.5 l/min). Overall length 2 1/2" (70 mm). Weight: 1 1/2 ounces (43 g).

SP835518	1/8"
SP835514	1/4"



SP12328	1/2"
SP12328-34	3/4"

12328-NYB

Made of Nylon with Celcon® bonnet. Check valve opens at 7 PSI (0.5 bar) pressure. (M) inlet connection and (F) outlet connections. Choice of 1/2" and 3/4" NPT sizes. Large capacity flow rates up to 10 GPM (38 l/min) for 1/2" NPT size, up to 15 GPM (57 l/min) for 3/4" NPT size. Overall length 3" (76 mm). Weight: 9 ounces (0.26 kg).



8360

Made of Nylon with Nylon/polypropylene end cap assembly. Check valve opens at 10 PSI (0.7 bar) pressure. 1/4" NPT (M) inlet connection. For flow rates up to 2 GPM (7.6 l/min). Overall length 2" (51 mm). Weight: 1 ounce (28 g).

SP8360V

ChemSaver® Diaphragm Check Valve Nozzle Bodies

Similar in design and performance to the TeeJet® Diaphragm Check Valve nozzle bodies, but with pipe thread outlet connections for spray nozzles instead of TeeJet caps and spray tips. For maximum operating pressures of 125 PSI (9 bar).



4664B

Made in choice of brass or aluminum with replaceable stainless steel valve seat. Check valve opens at 7 PSI (0.5 bar) pressure. 3/8" NPT (F) inlet connection. For flow rates up to 1.5 GPM (5.7 l/min). Overall length 2 5/8" (59 mm). Weights: brass 3 ounces (85 g), aluminum 1 ounce (28 g).

SP4664B



58140



56720

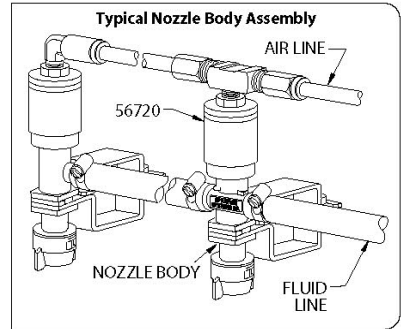

58140 ChemSaver Manual Shutoff

- Use with any application where individual shutoff is important such as golf course and estate sprayers.
- 150 PSI (10 bar) maximum pressure rating.
- Nylon construction.

56720 ChemSaver Air Shutoff Valve

Pneumatic Line Features:

- 56720 ChemSaver Air Shutoff Valve is designed as a pneumatic valve for use on Quick TeeJet® nozzle assemblies. Air pressure is used to open the valve and a spring is used to close the valve.
- Available in 1/8" NPT
 - Valve is normally closed.
 - Air consumption per valve: 0.015 CF/CYCLE (.0007 L/CYCLE).

System Line Features:

- Maximum 115 PSI (8 bar) liquid pressure.
- Must be compatible with Viton® polypropylene and polyurethane.
- 56720-1/8-F is for TeeJet nozzle bodies using one-piece diaphragm check valve with a flat diaphragm.
- 56720-1/8-B is for TeeJet nozzle bodies using two-piece diaphragm check valve with a bead diaphragm.

CHEMSAVER DIAPHRAGM CHECK VALVES	EXPLODED VIEW																	
<p>Back end of Diaphragm Check Valves (Brass)</p>	<p>SP6227 Diaphragm Teflon® (optional) To be used with 4620 Diaphragm</p>	<p>SP4620FA Diaphragm Fairprene® or Viton</p>	<p>SP9758 End Cap Subassembly Brass, Aluminum</p>	<p>SP4624 Retainer Brass, Aluminum</p>														
<p>Back end of Diaphragm Check Valves (Nylon)</p>	<p>SP6227 Diaphragm Teflon (optional) To be used with 21953 Diaphragm</p>	<p>SP21953 SP21953V Diaphragm EPDM or Viton</p> <p>Note: Nib on diaphragm fits into hole in end cap assembly.</p>	<p>21950-NYB ChemSaver End Cap Assembly Nylon/polypropylene</p>	<table border="1"> <thead> <tr> <th>PART NUMBER</th> <th>APPROXIMATE OPENING PRESSURE</th> </tr> </thead> <tbody> <tr> <td>SP21950-2 (YLW)</td> <td>2 PSI (0.14 bar)</td> </tr> <tr> <td>SP21950-8</td> <td>8 PSI (0.6 bar)</td> </tr> <tr> <td>SP21950-10 (STD)</td> <td>10 PSI (0.7 bar)</td> </tr> <tr> <td>SP21950-15 (RED)</td> <td>15 PSI (1 bar)</td> </tr> <tr> <td>SP21950-20</td> <td>20 PSI (1.4 bar)</td> </tr> <tr> <td>SP21950-30</td> <td>30 PSI (2 bar)</td> </tr> </tbody> </table>	PART NUMBER	APPROXIMATE OPENING PRESSURE	SP21950-2 (YLW)	2 PSI (0.14 bar)	SP21950-8	8 PSI (0.6 bar)	SP21950-10 (STD)	10 PSI (0.7 bar)	SP21950-15 (RED)	15 PSI (1 bar)	SP21950-20	20 PSI (1.4 bar)	SP21950-30	30 PSI (2 bar)
PART NUMBER	APPROXIMATE OPENING PRESSURE																	
SP21950-2 (YLW)	2 PSI (0.14 bar)																	
SP21950-8	8 PSI (0.6 bar)																	
SP21950-10 (STD)	10 PSI (0.7 bar)																	
SP21950-15 (RED)	15 PSI (1 bar)																	
SP21950-20	20 PSI (1.4 bar)																	
SP21950-30	30 PSI (2 bar)																	
<p>QJ353</p>	<p>SP56709 Diaphragm EPDM or Viton</p>	<p>SP56714 End Cap Subassembly</p>	<p>SP56711 Retaining Ring</p>															
<p>Hypro Nozzle Body Components (the complete line of Hypro boom components are available upon request - call to ensure availability.)</p> <p>TC5860-036 Diaphragm- EPDM TC5865-036 Diaphragm- Viton</p>																		

TeeJet® Swivel Nozzle Bodies



Quick TeeJet® Swivel Nozzle Bodies

QJ8600 swivel Quick TeeJet nozzle body assemblies provide the same spray tip adjustability of a standard TeeJet threaded swivel plus the quick change and self-aligning features of the Quick TeeJet System.



QJ8600-2-1/4-NYB
Double Swivel Nozzle

PART NUMBER	PIPE THREAD	MATERIAL
SPQ8600-2	1/4" NPT (F)	Nylon



QJ8600-1/4-NYB
Single Swivel Nozzle

PART NUMBER	PIPE THREAD	MATERIAL
SPQ8600	1/4" NPT (F)	Nylon

Swivel Nozzle Bodies

TeeJet swivel nozzle bodies are primarily for use with tips employed in row crop spraying. A locknut holds swivel bodies firmly in position at selected spray projection angle so they are not affected by jarring and vibration. For use at pressures up to 125 PSI (9 bar).



Type 5000
Single Swivel Nozzle

PART NUMBER	INLET CONNECTION	MATERIAL	SWIVEL ARC RANGE
SP5000	1/4" NPT (F)	Brass	280°



Type 4202
Double Swivel Nozzle

PART NUMBER	INLET CONNECTION	MATERIAL	SWIVEL ARC RANGE
SP4202-2	1/4" NPT (F)	Brass	280°



Type 5932
Double Swivel Nozzle 1/4" NPT female bottom outlet

PART NUMBER	INLET CONNECTION	MATERIAL	SWIVEL ARC RANGE
SP5932	1/4" NPT (F)	Brass	280°



Type 8600 Nylon
Single Swivel Nozzle

PART NUMBER	INLET CONNECTION	MATERIAL	SWIVEL ARC RANGE
SP8600	1/4" NPT (F)	Nylon	280°



Type 8600-2 Nylon
Double Swivel Nozzle

PART NUMBER	INLET CONNECTION	MATERIAL	SWIVEL ARC RANGE
SP8600-2	1/4" NPT (F)	Nylon	280°

Note: Swivels do not include tips, strainers or caps.

TeeJet® Hose Drops

Hose drops connect to standard and Quick TeeJet nozzle bodies and can also be used with swivels. Available in 15" (380 mm) and 24" (610 mm) lengths. Maximum operating pressure of 125 PSI (9 bar).

ITEM	HOSE DROP NUMBER	LENGTH	INLET CONNECTION	OUTLET CONNECTION	MATERIAL
A	SPQ2135315	15" (380 mm)	Quick TeeJet Type	1/4" NPT (M)	Nylon with Quick TeeJet cap and EPDM gasket
	SPQ2135324	24" (610 mm)			
B	SP2135415	15" (380 mm)	1/16" TeeJet Thread		Nylon
	SP2135424	24" (610 mm)			

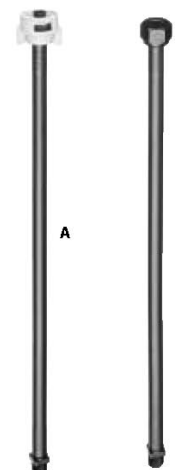



ROW APPLICATION KITS

The 23770 Adjustable Row Application Kit is for Applying Post-emergence Chemicals Over Crop Rows

Features:

- Arms adjustable for length and angle without removing bolts; simply loosen.
- Available with stainless steel arms.
- Positioning one arm at proper angle automatically sets correct angle of second arm.
- Fits square or round booms up to 1½" diameter.
- Kit includes standard and Quick TeeJet® nozzle bodies.
- Side nozzle bodies may be rotated.
- Maximum pressure of 125 PSI (9 bar).
- Spray tips and strainers not included.



Model #23770 Row Application Kit
(Supplied without spray tips and strainers)

SP23770-SS Teejet Row App Kit (pictured above), with Stainless Steel Arms (tips not included)

CYBASLEXLT Spray Tech Row App Kit (not pictured), with Lexan Arms (tips not included)



SPRAY TECH HEAVY-DUTY HOSE DROPS

Drop Length	Part Number by Connection Type			
	Female PT Connection	Female Quick Connection	Male PT Connection	Hardi Quick Connection
15"	CYDROPF	CYDROPFQ	CYDROPM	CYDROPFH
24"	CYDROPF24	CYDROPF24Q	-	-
36"	-	CYDROPF36Q	-	-

Additional configurations may be possible with the Spray Tech heavy-duty drop line. Call with any inquiries.

TeeJet® Hose Shank Nozzle Bodies

For Operating Pressures up to 125 PSI (9 bar)

Brass, stainless steel, Nylon and Celcon®/stainless steel hose shank nozzle bodies.

Single Hose Connection



15427
12670

HOSE SHANK BODY ASSEMBLY NUMBER	TO FIT HOSE I.D.	MATERIAL
SP15427	1/4"	Brass
SP12670	3/8"	Nylon

Triple Hose Connection

TCT38CN	3/8"	Nylon
TCT12CN	1/2"	Nylon
TCT34CN	3/4"	Nylon

Single Hose Connection



6471B
8121-NYB
9191B
12201-CE

HOSE SHANK BODY ASSEMBLY NUMBER	TO FIT HOSE I.D.	MATERIAL
SP6471	3/8"	Brass
SP6471SS	3/8"	Stainless Steel
TC8121-406	3/8"	Nylon
TC8121-540	1/2"	Nylon
SP9191	1/2"	Brass
SP9191SS	1/2"	Stainless Steel
SP1220134	3/4"	Celcon Hose Shank/ Stainless Steel Threaded Outlet
SP12201	1"	
TC8121-580	5/8"	Nylon
TC8121-750	3/4"	Nylon

Double Hose Connection



6472B
8120-NYB
9192B
12202-CE

HOSE SHANK BODY ASSEMBLY NUMBER	TO FIT HOSE I.D.	MATERIAL
SP6472	3/8"	Brass
SP6472SS	3/8"	Stainless Steel
TC8120-406	3/8"	Nylon
TC8120-540	1/2"	Nylon
SP9192	1/2"	Brass
SP9192SS	1/2"	Stainless Steel
SP1220234	3/4"	Celcon Hose Shank/ Stainless Steel Threaded Outlet
SP12202	1"	
TC8120-580	5/8"	Nylon
TC8120-750	3/4"	Nylon

TeeJet® Split Eyelet Nozzle Bodies

For Wet Booms

- Mounting on 1/2", 3/4" or 1" pipe or tubing.
- 25775-NYB mounts to 3/8" (9.5 mm) hole drilled in pipe or tubing.
- 7421 mounts to 7/32" (7.2 mm) hole drilled in pipe or tubing.



25775-NYB
Operating pressures up to 150 PSI



7421
Operating pressures up to 250 PSI

SPLIT EYELET ASSEMBLY NUMBER	MATERIAL	TO CLAMP ON
SP25775-12	Nylon	1/2" Pipe
		13/16" O.D. Tubing
		7/8" O.D. Tubing
SP25775-34	Nylon	3/4" Pipe
		1" O.D. Tubing
		1 1/16" O.D. Tubing
SP25775-1	Nylon	1" Pipe
		1 1/4" O.D. Tubing
		1 3/8" O.D. Tubing

SPLIT EYELET ASSEMBLY NUMBER	MATERIAL	TO CLAMP ON
SP7421-12	Brass	1/2" Pipe
	Stainless Steel	
SP7421-12S	Stainless Steel	13/16" O.D. Tubing
		7/8" O.D. Tubing
SP7421-34	Brass	3/4" Pipe
	Stainless Steel	
SP7421-34S	Stainless Steel	1" O.D. Tubing
		1 1/16" O.D. Tubing
SP7421-1	Brass	1" Pipe
	Stainless Steel	
SP7421-1S	Stainless Steel	1 1/4" O.D. Tubing
		1 3/8" O.D. Tubing



Standard Parts

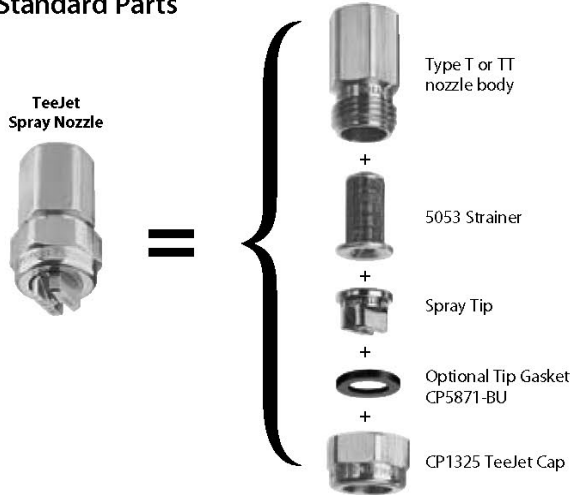

CP1325



CP18032A-NYB

TeeJet Nozzle Caps

Secure interchangeable TeeJet tips to the various nozzle bodies. 18032A-NYB winged TeeJet cap allows quick change of spray tips with no tool required.

TEEJET BODY NUMBER	MATERIAL
SP1325	Brass
SP8027	Nylon - Hex
TC8027	Nylon - Knurled (Hypro)
SP1325SS	Stainless Steel
SP18032A	Winged Cap, Nylon

11750 TeeJet Check Valve

For larger capacity TeeJet nozzles where strainers are not required. Ball check opens at 5 PSI (0.34 bar), 10 PSI (0.7 bar) spring also available. Recommended for flow rates from .40 to 1.5 GPM (1.5-5.7 l/min). Made in choice of stainless steel, brass, aluminum or polypropylene with stainless steel ball and spring.



45° Nozzle Body

Ideal for use with FullJet®, FloodJet® and Turbo FloodJet® nozzles. Can be used with QJ4676 Quick TeeJet® cap or standard 4676 outlet adapter. Made of polypropylene.



TEEJET BODY NUMBER	INLET	OUTLET
SP22669	¼" (M)	1¼"-16 (M)

TeeJet Nozzle Bodies



Type-TT
Male Inlet NPT

TEEJET BODY NUMBER	FOR TEEJET NOZZLE TYPE	MALE SIZE	MATERIAL
SP1336	1/8TT	⅛"	Brass
SP1322	1/4TT	¼"	Brass
SP8028	1/4TT-NYB	¼"	Nylon
SP1322SS	1/4TT-SS	¼"	Stainless Steel
SP1324	3/8TT	⅜"	Brass
SP1340	1/2TT	½"	Brass



Type-T
Female Inlet NPT or BSPT Connection

TEEJET BODY NUMBER	FOR TEEJET NOZZLE TYPE	FEMALE SIZE	MATERIAL
SP1335	1/8T	⅛"	Brass
SP1321	1/4T	¼"	Brass
SP12094	1/4T-NYB	¼"	Nylon
SP1321SS	1/4T-SS	¼"	Stainless Steel
SP1323	3/8T	⅜"	Brass
SP1339	1/2T	½"	Brass

How to order:

Specify part number.
Example: (B)22669-1/4-PPB

Clamp Assemblies

Consist of upper and lower clamps and bolt for use with hose shank nozzle bodies.



PART NUMBER	TO CLAMP ON
SP12VS	½" Pipe (1¼" & ⅝" O.D. Tubings)
SP34VS	¾" Pipe (1" & 1¼" O.D. Tubings)
SP1VS	1" Pipe (1½", 1¼" & 1¾" O.D. Tubings)
SP114VS	1¼" Pipe (1¾" & 1½" O.D. Tubings)



PART NUMBER	TO CLAMP ON
SP1SQVS	1" Square Tubing
SP114SQVS	1¼" Square Tubing
SP112SQVS	1½" Square Tubing



4676 TeeJet Outlet Adapters

Fits the outlets of TeeJet nozzle bodies as well as the outlets of various GunJet® spray guns and shutoff valves. Replaces CP1325 TeeJet cap. Used for attaching hose drops to nozzles or extensions to spray guns.

ADAPTER NUMBER	MATERIAL OUTLET CONNECTION	NPT (F)
SP4676-*	Brass	
SP4676-*N	Nylon	1/8" 1/4"
SP4676-*S	Stainless Steel	

*Specify outlet connection.



CP4928



CP6250



6406

TeeJet Outlet Fittings

These fittings replace spray tips and are used for attaching drop pipes to nozzle bodies or adding extensions to AA23 and AA31 GunJet spray guns and trigger valves.

CP4928 Adapter—Brass, aluminum or stainless steel. Length 1". 1/8" NPT female outlet connection.

CP6250 Adapter—Brass or steel. Length 3/16". 1/8" NPT female outlet connection.

CP6406 Adapter—Brass, aluminum or steel. Length 13/16". 1/8" NPT male outlet connection.

Plug Tip



CP3942 plug tip is used to temporarily shut off selected nozzles by replacing spray tips with these plug tips. Quick, easy way to change spacing of nozzles along boom. Materials: brass or stainless steel.

SP3942	brass
SP3942SS	stainless

TeeJet Hose Shanks

For attaching hose to nozzle body. Fits all standard TeeJet nozzle caps, replacing spray tips. Type 4251 is available in choice of brass, aluminum, stainless steel or electrofilmed aluminum. Type 8400 is made of Nylon.

NYLON HOSE SHANK NUMBER	FOR HOSE I.D.
SP8400-406	3/8"
SP8400-500	1/2"



8400



4251

TEEJET HOSE SHANK NUMBER	FOR HOSE I.D.	TEEJET HOSE SHANK NUMBER	FOR HOSE I.D.
SP4251-250	1/4"	SP4251-406	3/8"
		SP4251-500	1/2"



13435
13438

CONNECTOR NUMBER	NPT THREAD CONN.	FOR HOSE I.D.	MATERIAL
SP13435	1/4" (F)	3/8"	Nylon
SP13438	1/4" (F)	1/2"	Nylon



13436
13439

CONNECTOR NUMBER	NPT THREAD CONN.	FOR HOSE I.D.	MATERIAL
SP13434	1/4" (F)	3/8"	Nylon
SP13437	1/4" (F)	1/2"	Nylon





13434
13437

CONNECTOR NUMBER	NPT THREAD CONN.	FOR HOSE I.D.	MATERIAL
SP13436	1/4" (F)	3/8"	Nylon
SP13439	1/4" (F)	1/2"	Nylon

LINE STRAINERS

TEEJET LINE STRAINERS

SERIES 122 LINE STRAINERS

	STRAINER PART #	PIPE CONN. NPT (F)	HEAD (MATERIAL)	BOWL (MATERIAL)	SCREEN# (for ANY 122 strainer)	MESH	O-RING
 AA122	SP122-12-(mesh) SP122ML-12-(mesh)	1/2"	SP23171-12 SP45101-12	SP23172-P (Polypropylene)	SP23174-1	16	SP23173 (epdm-std.)
					SP23174-2	30	SP23173V (viton)
 37270-122-PP	SP122-34-(mesh) SP122ML-34-(mesh)	3/4"	SP23171-34 SP45101-34 (Polypropylene)	SP23172-N (clear nylon)	SP45102-3*	50	SP23173 (epdm-std.)
 AA122ML					SP45102-4*	80	SP23173V (viton)
					SP45102-5*	100	

SERIES 124 LINE STRAINERS (Series 124 strainers are being discontinued in favor of the 126 series. Strainers and parts will still be available while supplies last.)

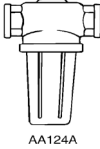
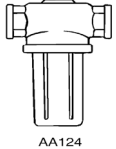
	STRAINER PART #	PIPE CONN. NPT (F)	HEAD (MATERIAL)	BOWL (MATERIAL)	SCREEN#	MESH	O-RING
 AA124A	SP124-34I	3/4"	SP15402-34I (Cast Iron)	SP15403 (Nylon)	SP16903-1* SP16903-3* SP16903-4* SP16903-5*	16 30 50 80	SP7717-226 (viton-std.)
	SP124-34AL		SP15402-34AL (Aluminum)				
	SP124-075P		SP16430-34 (Poly)				
	SP124-100I	1"	SP15402-1I (Cast Iron)				
	SP124-100AL		SP15402-1AL (Aluminum)				
SP124-100P	1"	SP16430-1 (Poly)	(above)				
 AA124	SP124-125I	1 1/4"	Cast Iron	SP15017 (nylon)	SP15941-1* SP15941-2* SP15941-3* SP15941-4*	16 30 50 80	SP12291 (epdm-std.) SP12291-V (viton)
	SP124-125AL		Aluminum				
	SP124-125N		SP15016125 (poly)				
	SP124-150I	1 1/2"	Cast Iron				
	SP124-150AL		Aluminum				
	SP124-150N		SP15016150 (poly)				
			(above)				

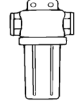

SERIES 124 LINE STRAINERS WITH MOUNTING LUGS (Series 124 strainers are being discontinued in favor of the 126 series. Strainers and parts will still be available while supplies last.)

	STRAINER#	PIPE CONN. NPT (F)	HEAD MATERIAL	BOWL MATERIAL	SCREEN#	MESH	O-RING
 AA124ML	SP124ML34AL	3/4"	SP19342-34	SP15403 (Nylon)	SP16903-1*	16	SP7717-226 (viton-std.)
	SP124ML1AL	1"			SP16903-3*	30	
	SP124ML125AL	1 1/4"	SP19342-1	SP12288 (Nylon)	SP16903-4*	50	SP12291
	SP124ML150AL	1 1/2"	SP19345-150		SP16903-5*	80	
					SP15941-1*	16	
					SP15941-2*	30	
			SP15941-3*	50			
			SP15941-4*	80			
	SP124ML2AL	2"	SP19348-2 (Aluminum)		SP14634-1	16	
					SP14634-2	30	
					SP14634-3	50	
					SP14634-4	80	

* With Polypropylene frame.

TEEJET LINE STRAINERS

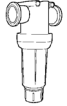
SERIES 126 FLUSH-OUT STRAINERS

	STRAINER #	PIPE CONN. NPT (F)	MATERIAL		SCREEN #	MESH (50 is std)	O-RING
			HEAD	BOWL			
 AA126-3 OR 4	SP126F50(mesh)	50 Series 1" Flange	Polypropylene SP50491	Polypropylene SP50493	SP16903-1* SP16903-3* SP16903-4* SP16903-5* SP16903-6* SP16903-7*	16 30 50 80 100 200	SP50494 (epdm) SP50494V (viton)
	SP1263(mesh)	3/4" NPT	SP50492-34	BOTTOM CAP: SP48655			
	SP1264(mesh)	1" NPT	SP50492-1	BOTTOM GASKET: SP63150 SP63150V			
 AA126-F50	SP126F75(mesh)	75 Series 2" Flange	Polypropylene SP63025	Polypropylene SP48654	SP15941-1* SP15941-2* SP15941-3* SP15941-4* SP15941-5* SP15941-6*	16 30 50 80 100 120	SP48656 (epdm) SP48656V (viton)
	SP1265(mesh)	1 1/4" NPT	SP63065	BOTTOM CAP: SP48655			
	SP1266(mesh)	1 1/2" NPT	SP63066	BOTTOM GASKET: SP63150 SP63150V			
 AA126-5 OR 6							

SERIES 124 SELF-CLEANING LINE STRAINERS

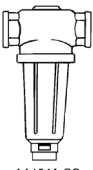
	STRAINER #	PIPE CONN. NPT (F)	MATERIAL		SCREEN #	MESH (50 is std)	
			HEAD	BOWL			
 AA124A-SC	SP124075SCAL	3/4"	Aluminum	Nylon	SP12285-1	16	Call Spray Tech for price & availability of specific self-cleaning strainer parts.
	SP1241SCAL	1"			SP12285-4	30	
	SP124125SCAL	1 1/4"	Aluminum	Nylon	SP12285-2	50	
	SP124150SCAL	1 1/2"			SP12285-3	80	
					SP12285-6	100	

SERIES 124 & 126 SELF-CLEANING LINE STRAINERS (with mounting lugs)

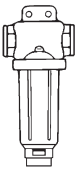
	STRAINER #	PIPE CONN. NPT (F)	MATERIAL		SCREEN #	MESH (50 is std)	
			HEAD	BOWL			
 AA126ML-3 or 4SC  AA124ML-SC	SP126M3S(mesh)	3/4"	Polypropylene		SP12285-1 SP12285-4 SP12285-2 SP12285-3 SP12285-6 SP12290-1 SP12290-2 SP12290-3 SP12290-4 SP12290-8	16 30 50 80 100	Call Spray Tech for price & availability of specific self-cleaning strainer parts.
	SP124M34S(mesh)		Aluminum	Nylon			
	SP126M4S(mesh)	1"	Polypropylene				
	SP124M1S(mesh)		Aluminum	Nylon			
	SP126L50FS(mesh)	Flange	Polypropylene				
	SP126M5S(mesh)	1 1/4"	Polypropylene				
	SP124M125S(mesh)		Aluminum	Nylon			
	SP126M6S(mesh)	1 1/2"	Polypropylene				
	SP124M150S(mesh)		Aluminum	Nylon			
	SP126M75FS(mesh)	Flange	Polypropylene				

* With Polypropylene frame.



Polypropylene Mini "T" Line Strainers

FEATURES

- Heavy-duty glass reinforced polypropylene.
- Clear or black polypropylene bowl.
- Polypropylene ribbed 304 stainless steel screens.
- EPDM gaskets standard. FKM (viton type) available.
- Clear Bowl Max 100 P.S.I. at 70°F. Black Bowl Max 150 P.S.I. at 70°F.
- Convenient color coded screens for easy mesh size identification. (Refer to chart below)



1/2" Mini T-Strainer with Clear Bowl



1/2" Mini T-Strainer with Black Bowl

1/2" POLY RIBBED SCREEN COLOR CHART

MESH SIZE	RIB COLOR
30 Mesh	Yellow
50 Mesh	Red
80 Mesh	Blue
100 Mesh	Green

1/2" Mini T-Strainer with Clear Bowl

PART NO.	SIZE	DESCRIPTION	QTY.
LSTM050 30C	1/2" x 1/2"	Clear Bowl Strainer 30 Mesh Scr.	1
LSTM050 50C	1/2" x 1/2"	Clear Bowl Strainer 50 Mesh Scr.	1
LSTM050 80C	1/2" x 1/2"	Clear Bowl Strainer 80 Mesh Scr.	1
LSTM050 100C	1/2" x 1/2"	Clear Bowl Strainer 100 Mesh Scr.	1

1/2" Mini T-Strainer with Black Bowl

PART NO.	SIZE	DESCRIPTION	QTY.
LSTM050 30	1/2" x 1/2"	Clear Bowl Strainer 30 Mesh Scr.	1
LSTM050 50	1/2" x 1/2"	Clear Bowl Strainer 50 Mesh Scr.	1
LSTM050 80	1/2" x 1/2"	Clear Bowl Strainer 80 Mesh Scr.	1
LSTM050 100	1/2" x 1/2"	Clear Bowl Strainer 100 Mesh Scr.	1

3/4" Mini T-Strainer with Clear Bowl

PART NO.	SIZE	DESCRIPTION	QTY.
LSTM075 30C	3/4" x 3/4"	Clear Bowl Strainer 30 Mesh Scr.	1
LSTM075 50C	3/4" x 3/4"	Clear Bowl Strainer 50 Mesh Scr.	1
LSTM075 80C	3/4" x 3/4"	Clear Bowl Strainer 80 Mesh Scr.	1
LSTM075 100C	3/4" x 3/4"	Clear Bowl Strainer 100 Mesh Scr.	1

3/4" Mini T-Strainer with Black Bowl

PART NO.	SIZE	DESCRIPTION	QTY.
LSTM075 30	3/4" x 3/4"	Clear Bowl Strainer 30 Mesh Scr.	1
LSTM075 50	3/4" x 3/4"	Clear Bowl Strainer 50 Mesh Scr.	1
LSTM075 80	3/4" x 3/4"	Clear Bowl Strainer 80 Mesh Scr.	1
LSTM075 100	3/4" x 3/4"	Clear Bowl Strainer 100 Mesh Scr.	1

STANDARD MESHES AND DATA (For General Use Only)

MESH	MICRONS	WIRE DIAM.	OPENING	% OPEN AREA	MESH	MICRONS	WIRE DIAM.	OPENING	% OPEN AREA
6 Mesh	3360	.035	.132	62.7	30 Mesh	595	.012	.021	40.8
8 Mesh	2380	.028	.097	60.2	40 Mesh	446	.012	.021	36.0
10 Mesh	2000	.025	.075	56.3	50 Mesh	297	.009	.011	30.3
12 Mesh	1680	.023	.060	51.8	80 Mesh	177	.0055	.007	31.4
16 Mesh	1190	.018	.044	50.7	100 Mesh	149	.0045	.005	30.3
20 Mesh	841	.016	.034	46.2	120 Mesh	116	.0037	.0046	30.5



The Spray Tech part number can be derived by adding the prefix 'TE' to the listed Banjo part numbers.

BANJO®

LINE STRAINERS

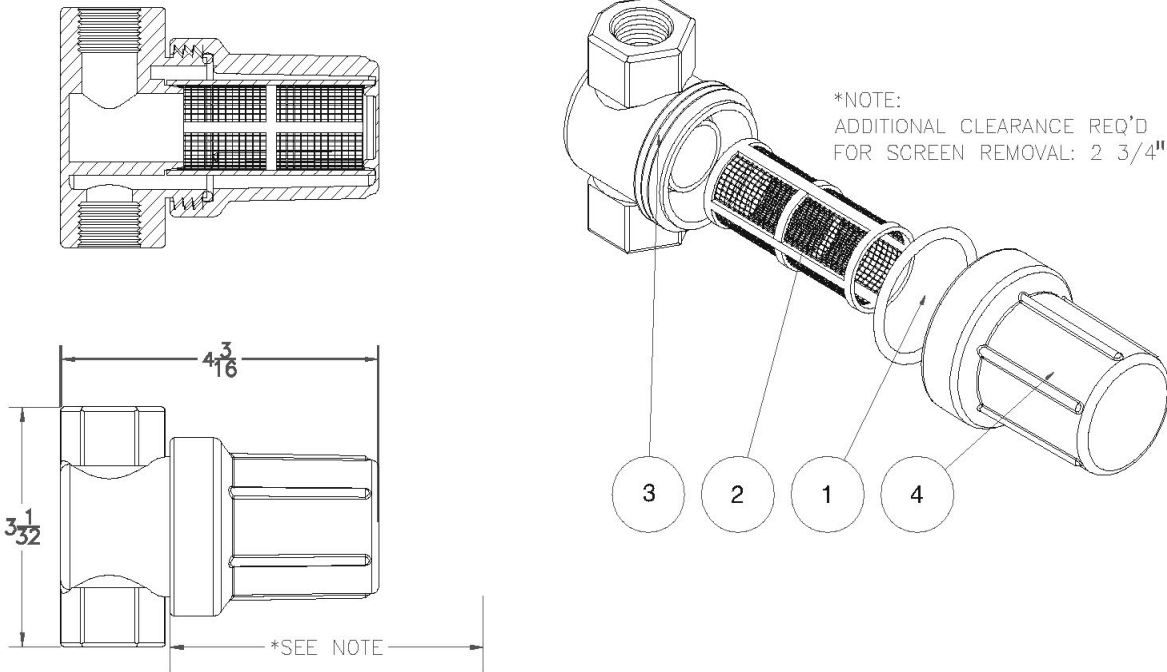

REPLACEMENT PARTS 1/2" & 3/4" Mini T-Strainer with Clear Bowl				
ITEM	PART NO.	DESCRIPTION	QTY.	
1	LSTM050G	EPDM Gasket	1	
1	UV10264V	FKM (viton type) O-Ring	1	
2	LST530	30 Mesh Screen	1	
2	LST550	50 Mesh Screen	1	
2	LST580	80 Mesh Screen	1	
2	LST5100	100 Mesh Screen	1	
3	LST050H	1/2" Strainer Head	1	
3	LST075H2	3/4" Strainer Head	1	
4	LST050BC	Clear Bowl	1	

REPLACEMENT PARTS 1/2" & 3/4" Mini T-Strainer with Black Bowl				
ITEM	PART NO.	DESCRIPTION	QTY.	
1	LSTM050G	EPDM O-Gasket	1	
1	UV10264V	FKM (viton type) O-Ring	1	
2	LST530	30 Mesh Screen	1	
2	LST550	50 Mesh Screen	1	
2	LST580	80 Mesh Screen	1	
2	LST5100	100 Mesh Screen	1	
3	LST050H	1/2" Strainer Head	1	
3	LST075H2	3/4" Strainer Head	1	
4	LST050B	Mini T-Strainer Bowl	1	

The Spray Tech part number can be derived by adding the prefix 'TE' to the listed Banjo part numbers.



Polypropylene "Y" Strainers



2" POLY RIBBED SCREEN COLOR CHART

MESH SIZE	RIB COLOR
6 Mesh	White
12 Mesh	Black
20 Mesh	Beige
30 Mesh	Yellow
40 Mesh	Brown
50 Mesh	Red
80 Mesh	Blue
100 Mesh	Green
120 Mesh	Black

FEATURES

- Precision molded construction.
- Corrosion resistant.
- Lightweight.
- Fiberglass reinforced.
- Easy grip end cap.
- Poly ribbed 316 stainless steel screen.
- EPDM gaskets FKM (viton type) available.
- Heavy duty end cap threads.
- 1/2"-1 1/4" 75 P.S.I. Maximum.
- 1/2"- 2" 150 P.S.I. Maximum.
- Clean-out plug.
- Female NPT x Female NPT.

1/2" THRU 1 1/4" WITH SS SCREEN

PART NO.	SIZE	DESCRIPTION	QTY.
LS050 20	1/2" x 1/2"	Strainer 20 Mesh S.S. Screen	1 pc.
LS050 40	1/2" x 1/2"	Strainer 40 Mesh S.S. Screen	1 pc.
LS050 80	1/2" x 1/2"	Strainer 80 Mesh S.S. Screen	1 pc.
LS075 20	3/4" x 3/4"	Strainer 20 Mesh S.S. Screen	1 pc.
LS075 40	3/4" x 3/4"	Strainer 40 Mesh S.S. Screen	1 pc.
LS075 80	3/4" x 3/4"	Strainer 80 Mesh S.S. Screen	1 pc.
LS100 20	1" x 1"	Strainer 20 Mesh S.S. Screen	1 pc.
LS100 40	1" x 1"	Strainer 40 Mesh S.S. Screen	1 pc.
LS100 80	1" x 1"	Strainer 80 Mesh S.S. Screen	1 pc.
LS125 20	1 1/4" x 1 1/4"	Strainer 20 Mesh S.S. Screen	1 pc.
LS125 40	1 1/4" x 1 1/4"	Strainer 40 Mesh S.S. Screen	1 pc.
LS125 80	1 1/4" x 1 1/4"	Strainer 80 Mesh S.S. Screen	1 pc.

1 1/2" THRU 2" POLY RIBBED WITH 316 SS SCREEN

PART NO.	SIZE	DESCRIPTION	QTY.
LS150 06	1 1/2" x 1 1/2"	Strainer 6 Mesh AI Poly Screen	12
LS150 12	1 1/2" x 1 1/2"	Strainer 12 Mesh S.S. Screen	12
LS150 20	1 1/2" x 1 1/2"	Strainer 20 Mesh S.S. Screen	12
LS150 30	1 1/2" x 1 1/2"	Strainer 30 Mesh S.S. Screen	12
LS150 50	1 1/2" x 1 1/2"	Strainer 50 Mesh S.S. Screen	12
LS150 80	1 1/2" x 1 1/2"	Strainer 80 Mesh S.S. Screen	12
LS150 120	1 1/2" x 1 1/2"	Strainer 120 Mesh S.S. Screen	12
LS200 06	2" x 2"	Strainer 6 Mesh AI Poly Screen	12
LS200 08	2" x 2"	Strainer 8 Mesh S.S. Screen	12
LS200 12	2" x 2"	Strainer 12 Mesh S.S. Screen	12
LS200 20	2" x 2"	Strainer 20 Mesh S.S. Screen	12
LS200 30	2" x 2"	Strainer 30 Mesh S.S. Screen	12
LS200 50	2" x 2"	Strainer 50 Mesh S.S. Screen	12
LS200 80	2" x 2"	Strainer 80 Mesh S.S. Screen	12
LS200 100	2" x 2"	Strainer 100 Mesh S.S. Screen	12
LS200 120	2" x 2"	Strainer 120 Mesh S.S. Screen	12

STANDARD MESHES AND DATA (For General Use Only)

MESH	MICRONS	WIRE DIAM.	OPENING	% OPEN AREA	MESH	MICRONS	WIRE DIAM.	OPENING	% OPEN AREA
6 Mesh	3360	.035	.132	62.7	30 Mesh	595	.012	.021	40.8
8 Mesh	2380	.028	.097	60.2	40 Mesh	446	.012	.021	36.0
10 Mesh	2000	.025	.075	56.3	50 Mesh	297	.009	.011	30.3
12 Mesh	1680	.023	.060	51.8	80 Mesh	177	.0055	.007	31.4
16 Mesh	1190	.018	.044	50.7	100 Mesh	149	.0045	.005	30.3
20 Mesh	841	.016	.034	46.2	120 Mesh	116	.0037	.0046	30.5



The Spray Tech part number can be derived by adding the prefix 'TE' to the listed Banjo part numbers.

BANJO®

LINE STRAINERS

REPLACEMENT PARTS 1/2" - 2" POLY "Y" STRAINER			
ITEM	PART NO.	DESCRIPTION	QTY.
1*	LS075-C1	End Cap (Fits 1/2"-3/4" Strainer)	1
1*	LS100-C1	End Cap (Fits 1"-1 1/4" Strainer)	1
1*	LS150-C	End Cap (Fits 1 1/2"-2" Strainer) New Style	1
2	LS075-G	Gasket (Fits 1/2"-3/4" Strainer-O-Ring)	1
2	LS100-G	Gasket (Fits 1"-1 1/4" Strainer-O-Ring)	1
2	LS150-G	Gasket (Fits 1 1/2"-2" Strainer) New Style O-Ring (thicker)	1
2	LS075-GV	Gasket-FKM (viton type) (Fits 1/2"-3/4" Strainer)	1
2	LS100-GV	Gasket-FKM (viton type)(Fits 1"-1 1/4" Strainer)	1
2	LS150-GV	Gasket-FKM (viton type)(Fits 1 1/2"-2" Strainer) O-ring	1
3	12777	1/2" Drain Plug (Fits 1" and 1 1/4" strainers)	1
3	LSQ200-PL	1" Drain Plug (Fits 1 1/2" and 2" strainers)	1
3	12723	1/4" Drain Plug (Fits 1/2" and 3/4" Strainers)	1
4	12724	EPDM O-Ring for Drain Plug (Fits 1/2" and 3/4")	1
4	UV15163	EPDM O-Ring for Drain Plug (Fits 1" and 1 1/4")	1
4	UV15163V	FKM (viton type) O-Ring for Drain Plug (Fits 1" and 1 1/4" strainers)	1
4	LSQ200-R	EPDM O-Ring for Drain Plug (Fits 1 1/2" & 2")	1
4	LSQ200-RV	FKM (viton type) O-Ring for Drain Plug (Fits 1 1/2" and 2" strainers)	1
5	LS720	20 Mesh Screen (Fits 1/2"-3/4" Strainer)	1
5	LS740	40 Mesh Screen (Fits 1/2"-3/4" Strainer)	1
5	LS780	80 Mesh Screen (Fits 1/2"-3/4" Strainer)	1
5	LS120	20 Mesh Screen (Fits 1"-1 1/4" Strainer)	1
5	LS140	40 Mesh Screen (Fits 1"-1 1/4" Strainer)	1
5	LS180	80 Mesh Screen (Fits 1"-1 1/4" Strainer)	1
5	LS206	6 Mesh All Poly Screen (Fits 1 1/2"-2" Strainer)	1
5	LS208	8 Mesh Screen (Fits 1 1/2"-2" Strainer)	1
5	LS212	12 Mesh Screen (Fits 1 1/2"-2" Strainer)	1
5	LS220	20 Mesh Screen (Fits 1 1/2"-2" Strainer)	1
5	LS230	30 Mesh Screen (Fits 1 1/2"-2" Strainer)	1
5	LS250	50 Mesh Screen (Fits 1 1/2"-2" Strainer)	1
5	LS280	80 Mesh Screen (Fits 1 1/2"-2" Strainer)	1
5	LS2100	100 Mesh Screen (Fits 1 1/2"-2" Strainer)	1
5	LS2120	120 Mesh Screen (Fits 1 1/2"-2" Strainer)	1
5	LS212P	12 Mesh All Poly Screen (Fits 1 1/2"-2" Strainer)	1
5	LS220P	20 Mesh All Poly Screen (Fits 1 1/2"-2" Strainer)	1
5	LS250P	50 Mesh All Poly Screen (Fits 1 1/2"-2" Strainer)	1
6	MLS100B	"Y" Body, 1" Manifold Flange	1
6	LS200-B	"Y" Body, 2"	1
6	LS150-B	"Y" Body, 1 1/2"	1
7	LS141G	EPDM O-Ring (Fits 1 1/2"- 2" Screens)	1
7	LS125G	EPDM O-Ring (Fits 1" and 1 1/4" Screens)	1
N/A	LS050B/C1	"Y" Body, Cap and Gasket, 1/2"	1
N/A	LS075B/C1	"Y" Body, Cap and Gasket, 3/4"	1
N/A	LS100B/C1	"Y" Body, Cap and Gasket, 1"	1
N/A	LS125B/C1	"Y" Body, Cap and Gasket, 1 1/4"	1
N/A	LS150B/C	"Y" Body, Cap and Gasket, 1 1/2"	1
N/A	LS200B/C	"Y" Body and Cap and Gaskets	1

NOTE: Items Marked with Asterisk* comes with parts 1, 3, and 4.

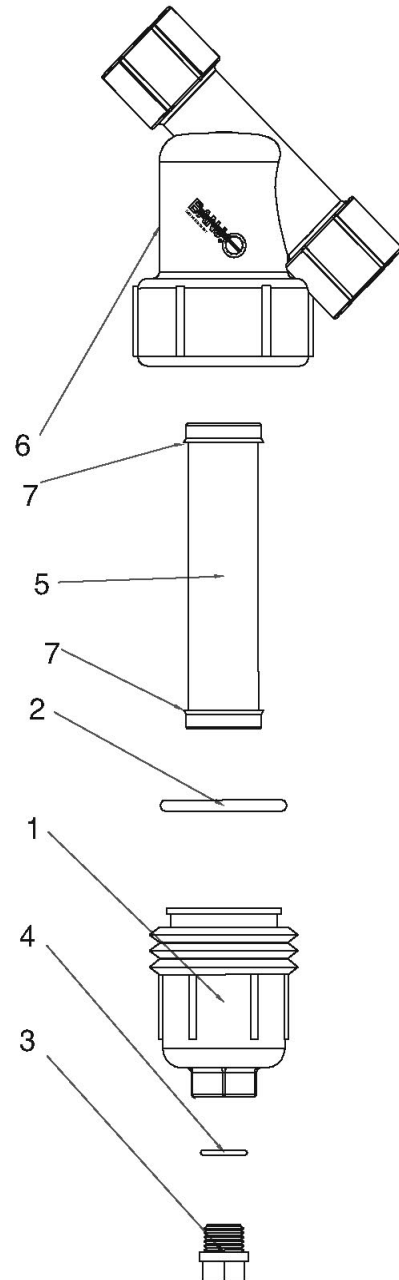

The Spray Tech part number can be derived by adding the prefix 'TE' to the listed Banjo part numbers.



Polypropylene "T" Line Strainers



3/4" And 1"

FEATURES

- Heavy-duty glass reinforced polypropylene.
- Clean-out plug.
- 304 stainless steel reinforced screens.
- EPDM gaskets standard. FKM (viton type) available.
- 150 PS.I. at 70°F.

2" POLY RIBBED SCREEN COLOR CHART

MESH SIZE	RIB COLOR
6 Mesh	White
12 Mesh	Black
20 Mesh	Beige
30 Mesh	Yellow
40 Mesh	Brown
50 Mesh	Red
80 Mesh	Blue
100 Mesh	Green
120 Mesh	Black



1 1/4" And 1 1/2"

3/4" AND 1" POLY "T" STRAINERS

PART NO.	SIZE	DESCRIPTION	QTY.
LST075 16	3/4" x 3/4"	Strainer 16 Mesh S.S. Screen	1
LST075 30	3/4" x 3/4"	Strainer 30 Mesh S.S. Screen	1
LST075 50	3/4" x 3/4"	Strainer 50 Mesh S.S. Screen	1
LST075 80	3/4" x 3/4"	Strainer 80 Mesh S.S. Screen	1
LST075 100	3/4" x 3/4"	Strainer 100 Mesh S.S. Screen	1
LST100 16	1" x 1"	Strainer 16 Mesh S.S. Screen	1
LST100 30	1" x 1"	Strainer 30 Mesh S.S. Screen	1
LST100 50	1" x 1"	Strainer 50 Mesh S.S. Screen	1
LST100 80	1" x 1"	Strainer 80 Mesh S.S. Screen	1
LST100 100	1" x 1"	Strainer 100 Mesh S.S. Screen	1

1 1/4" AND 1 1/2" POLY "T" STRAINERS

PART NO.	SIZE	DESCRIPTION	QTY.
LST125 16	1 1/4" x 1 1/4"	Strainer 16 Mesh S.S. Screen	1
LST125 30	1 1/4" x 1 1/4"	Strainer 30 Mesh S.S. Screen	1
LST125 50	1 1/4" x 1 1/4"	Strainer 50 Mesh S.S. Screen	1
LST125 80	1 1/4" x 1 1/4"	Strainer 80 Mesh S.S. Screen	1
LST125 100	1 1/4" x 1 1/4"	Strainer 100 Mesh S.S. Screen	1
LST150 16	1 1/2" x 1 1/2"	Strainer 16 Mesh S.S. Screen	1
LST150 30	1 1/2" x 1 1/2"	Strainer 30 Mesh S.S. Screen	1
LST150 50	1 1/2" x 1 1/2"	Strainer 50 Mesh S.S. Screen	1
LST150 80	1 1/2" x 1 1/2"	Strainer 80 Mesh S.S. Screen	1
LST150 100	1 1/2" x 1 1/2"	Strainer 100 Mesh S.S. Screen	1

STANDARD MESHES AND DATA (For General Use Only)

MESH	MICRONS	WIRE DIAM.	OPENING	% OPEN AREA	MESH	MICRONS	WIRE DIAM.	OPENING	% OPEN AREA
6 Mesh	3360	.035	.132	62.7	30 Mesh	595	.012	.021	40.8
8 Mesh	2380	.028	.097	60.2	40 Mesh	446	.012	.021	36.0
10 Mesh	2000	.025	.075	56.3	50 Mesh	297	.009	.011	30.3
12 Mesh	1680	.023	.060	51.8	80 Mesh	177	.0055	.007	31.4
16 Mesh	1190	.018	.044	50.7	100 Mesh	149	.0045	.005	30.3
20 Mesh	841	.016	.034	46.2	120 Mesh	116	.0037	.0046	30.5



The Spray Tech part number can be derived by adding the prefix 'TE' to the listed Banjo part numbers.

BANJO®

LINE STRAINERS

REPLACEMENT PARTS 3/4" AND 1" POLY "T" STRAINER			
ITEM	PART NO.	DESCRIPTION	QTY.
1*	LST100-B	Poly "T" Strainer Bowl (Fits 3/4" & 1") Includes Items 1, 3 & 4	1
2	LST100-G	Poly "T" Strainer Gasket (Fits 3/4" & 1")	1
2	LST100-GV	Poly "T" Strainer Gasket (Fits 3/4" & 1") FKM (viton type)	1
3	12777	Clean-Out Plug - 1/2"	1
4	UV15163	O-Ring for Clean-Out Plug - EPDM	1
4	UV15163V	O-Ring for Clean-Out Plug-FKM (viton type)	1
5	LST116	16 Mesh Screen (Fits 3/4" & 1" "T" strainer)	1
5	LST130	30 Mesh Screen (Fits 3/4" & 1" "T" strainer)	1
5	LST150	50 Mesh Screen (Fits 3/4" & 1" "T" strainer)	1
5	LST180	80 Mesh Screen (Fits 3/4" & 1" "T" strainer)	1
5	LST1100	100 Mesh Screen (Fits 3/4" & 1" "T" strainer)	1
6	LST100-H	1" Poly "T" Strainer Head	1
6	LST075-H	3/4" Poly "T" Strainer Head	1
7	13778	EPDM O-Ring (Fits 3/4" & 1" Screens)	1
N/S	LST075-HB	3/4" Poly "T" Strainer Head, Bowl & Gasket	1
N/S	LST100-HB	1" Poly "T" Strainer Head, Bowl & Gasket	1

NOTE: Items Marked with Asterisk* comes with parts 1, 3, and 4.

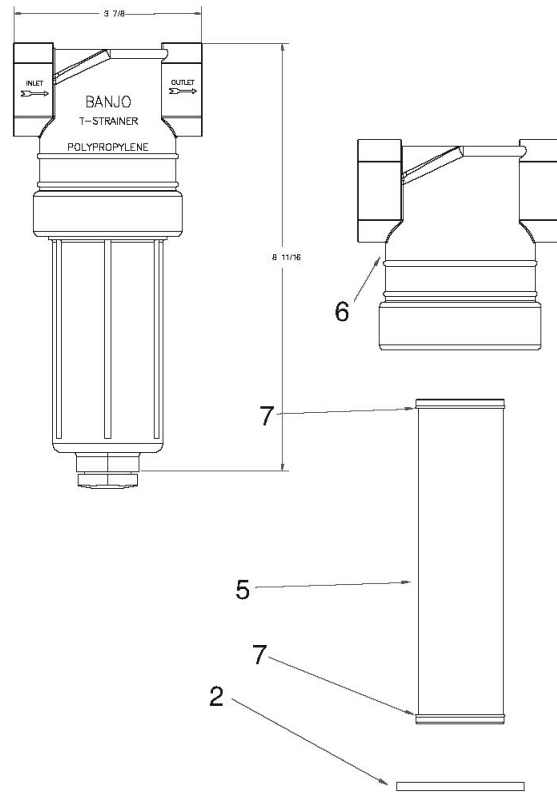

REPLACEMENT PARTS 1 1/4" AND 1 1/2" POLY "T" STRAINER			
ITEM	PART NO.	DESCRIPTION	QTY.
1*	LST150-B	Poly "T" Strainer Bowl (Fits 1 1/4" & 1 1/2") Includes Items 1, 3 & 4	1
2	LST150-GV	Poly "T" Strainer Gasket - FKM (viton type) (Fits 1 1/4" & 1 1/2")	1
2	LST150-G	Poly "T" Strainer Gasket (Fits 1 1/4" & 1 1/2")	1
3	LSQ200-PL	Clean-Out Plug	1
4	LSQ200-R	O-Ring for Clean-Out Plug - EPDM	1
4	LSQ200-RV	O-Ring for Clean-Out Plug - FKM (viton type)	1
5	LST1518	16 Mesh Screen (Fits 1 1/4" & 1 1/2" "T" strainer)	1
5	LST1530	30 Mesh Screen (Fits 1 1/4" & 1 1/2" "T" strainer)	1
5	LST1550	50 Mesh Screen (Fits 1 1/4" & 1 1/2" "T" strainer)	1
5	LST1580	80 Mesh Screen (Fits 1 1/4" & 1 1/2" "T" strainer)	1
5	LST15100	100 Mesh Screen (Fits 1 1/4" & 1 1/2" "T" strainer)	1
6	LST125-H	1 1/4" Poly "T" Strainer Head	1
6	LST150-H	1 1/2" Poly "T" Strainer Head	1
7	LST034G	EPDM O-Ring (Fits 1 1/4" & 1 1/2" Screens)	1
N/S	LST125-HB	1 1/4" Poly "T" Strainer Head, Bowl & Gasket	1
N/S	LST150-HB	1 1/2" Poly "T" Strainer Head, Bowl & Gasket	1

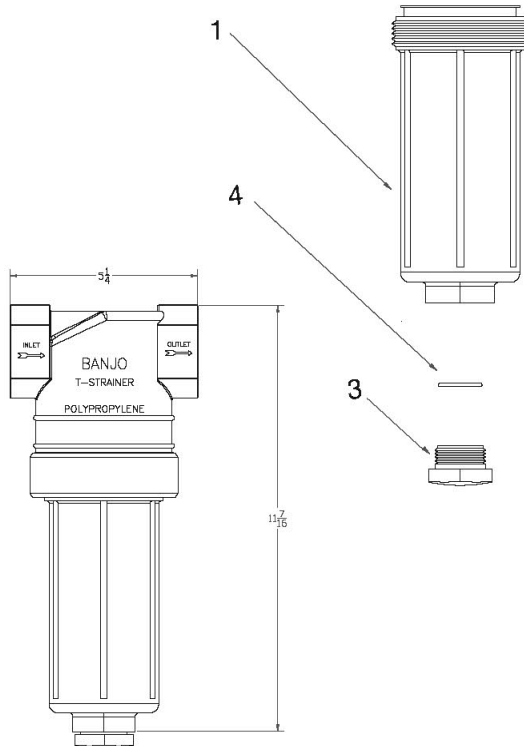

The Spray Tech part number can be derived by adding the prefix 'TE' to the listed Banjo part numbers.



2" "T" Line Strainer — Poly/Stainless Combo

2" FEATURES

- 316 stainless steel head.
- Glass reinforced polypropylene bowl.
- Clean-out plug.
- 316 stainless steel reinforced screens.
- FKM (viton type) gaskets.
- 150 P.S.I. at 70°F.



2" POLY RIBBED SCREEN COLOR CHART

MESH SIZE	RIB COLOR
6 Mesh	White
12 Mesh	Black
20 Mesh	Beige
30 Mesh	Yellow
40 Mesh	Brown
50 Mesh	Red
80 Mesh	Blue
100 Mesh	Green
120 Mesh	Black

2" POLY / STAINLESS "T" STRAINERS

PART NO.	DESCRIPTION	QTY.
LST200-04SS	2" "T" Strainer (316 S.S. hd-p bowl) - 4 Mesh Screen	1 pc.
LST200-06SS	2" "T" Strainer (316 S.S. hd-p bowl) - 6 Mesh Screen	1 pc.
LST200-08SS	2" "T" Strainer (316 S.S. hd-p bowl) - 8 Mesh Screen	1 pc.
LST200-10SS	2" "T" Strainer (316 S.S. hd-p bowl) - 10 Mesh Screen	1 pc.
LST200-16SS	2" "T" Strainer (316 S.S. hd-p bowl) - 16 Mesh Screen	1 pc.
LST200-30SS	2" "T" Strainer (316 S.S. hd-p bowl) - 30 Mesh Screen	1 pc.
LST200-50SS	2" "T" Strainer (316 S.S. hd-p bowl) - 50 Mesh Screen	1 pc.
LST200-80SS	2" "T" Strainer (316 S.S. hd-p bowl) - 80 Mesh Screen	1 pc.
LST200-100SS	2" "T" Strainer (316 S.S. hd-p bowl) - 100 Mesh Screen	1 pc.

LSQ Polypropylene Line Strainers

FEATURES

- Precision molded in glass reinforced polypropylene.
- Cam lever configuration for easy access for cleaning and servicing.
- 3/4" plug in cam lever cap for attaching ball valve for draining or back flushing.
- Poly ribbed stainless steel screen.
- EPDM lathe cut gasket.
- FKM (viton type) gaskets available.
- 75 P.S.I. maximum.



STANDARD MESHES AND DATA

MESH	MICRONS	WIRE DIAM.	OPENING	% OPEN AREA
6 Mesh	3360	.035	.132	62.7
12 Mesh	1680	.023	.060	51.8
20 Mesh	841	.016	.034	46.2
30 Mesh	595	.012	.021	40.8
50 Mesh	297	.009	.011	30.3
80 Mesh	177	.0055	.007	31.4
120 Mesh	116	.0037	.0046	30.5

LSQ SERIES POLY STRAINERS

PART NO.	DESCRIPTION	QTY.
LSQ150-06	1 1/2" x 1 1/2"; LSQ Line Strnr - All Poly 6 Mesh Screen	6/Box
LSQ150-12	1 1/2" x 1 1/2"; LSQ Line Strnr - 12 Mesh Screen	6/Box
LSQ150-20	1 1/2" x 1 1/2"; LSQ Line Strnr - 20 Mesh Screen	6/Box
LSQ150-30	1 1/2" x 1 1/2"; LSQ Line Strnr - 30 Mesh Screen	6/Box
LSQ150-50	1 1/2" x 1 1/2"; LSQ Line Strnr - 50 Mesh Screen	6/Box
LSQ150-80	1 1/2" x 1 1/2"; LSQ Line Strnr - 80 Mesh Screen	6/Box
LSQ150-120	1 1/2" x 1 1/2"; LSQ Line Strnr - 120 Mesh Screen	6/Box
LSQ200-06	2" x 2"; LSQ Line Strainer - All Poly 6 Mesh Screen	6/Box
LSQ200-12	2" x 2"; LSQ Line Strainer - 12 Mesh Screen	6/Box
LSQ200-20	2" x 2"; LSQ Line Strainer - 20 Mesh Screen	6/Box
LSQ200-30	2" x 2"; LSQ Line Strainer - 30 Mesh Screen	6/Box
LSQ200-50	2" x 2"; LSQ Line Strainer - 50 Mesh Screen	6/Box
LSQ200-80	2" x 2"; LSQ Line Strainer - 80 Mesh Screen	6/Box
LSQ200-120	2" x 2"; LSQ Line Strainer - 120 Mesh Screen	6/Box



The Spray Tech part number can be derived by adding the prefix 'TE' to the listed Banjo part numbers.

BANJO®

LINE STRAINERS

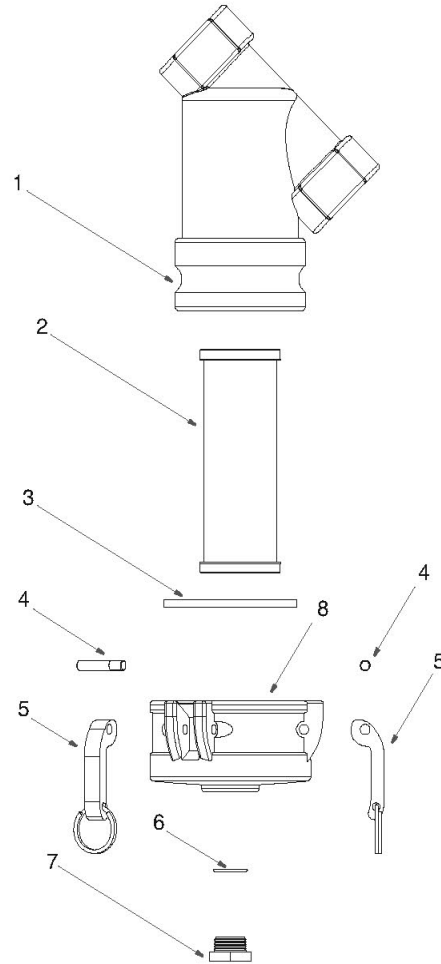
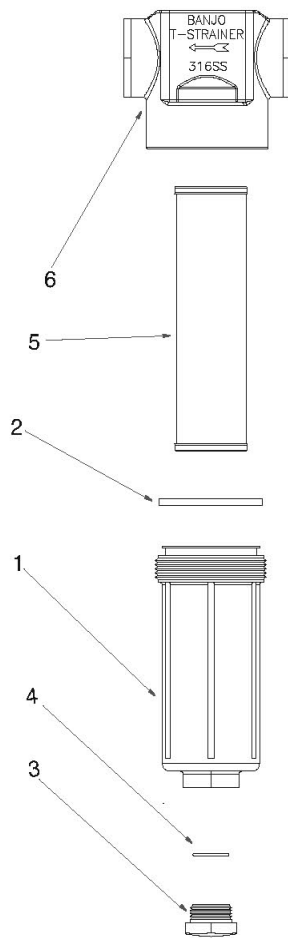

REPLACEMENT PARTS 2" "T" STRAINERS (316 S.S. HD W/POLY BOWL)			
ITEM	PART NO.	DESCRIPTION	QTY.
1	LST200-B	2" "T" Strainer Poly Bowl	1
2	LST200-GV	2" "T" Strainer Gasket – FKM (viton type)	1
3	LSQ200-PL	1" Clean-Out Plug	1
4	LSQ200-RV	O-Ring for Clean-Out Plug – FKM (viton type)	1
5	LST204SS	4 Mesh Screen (Fits 2" "T" Strainer)	1
5	LST208SS	6 Mesh Screen (Fits 2" "T" Strainer)	1
5	LST208SS	8 Mesh Screen (Fits 2" "T" Strainer)	1
5	LST210SS	10 Mesh Screen (Fits 2" "T" Strainer)	1
5	LST216SS	16 Mesh Screen (Fits 2" "T" Strainer)	1
5	LST230SS	30 Mesh Screen (Fits 2" "T" Strainer)	1
5	LST250SS	50 Mesh Screen (Fits 2" "T" Strainer)	1
5	LST280SS	80 Mesh Screen (Fits 2" "T" Strainer)	1
5	LST2100SS	100 Mesh Screen (Fits 2" "T" Strainer)	1
6	LST200-HSS	2" "T" Strainer 316 S.S. Head	1
N/A	LST200-HBSS	2" "T" Strainer 316 S.S. Head, Poly Bowl and Gasket	1

REPLACEMENT PARTS LSQ POLY "Y" STRAINER			
ITEM	PART NO.	DESCRIPTION	QTY.
1	LSQ150-B	1 1/2" LSQ Line Strainer Body	1
1	LSQ200-B	2" LSQ Line Strainer Body	1
2	LS206	All Poly 6 Mesh Screen (Fits 1 1/2" & 2" Screen)	1
2	LS212	12 Mesh Screen (Fits 1 1/2" & 2" Strainers)	1
2	LS220	20 Mesh Screen (Fits 1 1/2" & 2" Strainers)	1
2	LS230	30 Mesh Screen (Fits 1 1/2" & 2" Strainers)	1
2	LS250	50 Mesh Screen (Fits 1 1/2" & 2" Strainers)	1
2	LS280	80 Mesh Screen (Fits 1 1/2" & 2" Strainers)	1
2	LS2120	120 Mesh Screen (Fits 1 1/2" & 2" Strainers)	1
3	LSQ200-G	2" Gasket (Fits 1 1/2" & 2") – EPDM	1
3	LSQ200-GV	2" Gasket (Fits 1 1/2" & 2") – FKM (viton type)	1
4	300P	Cam Pin Stainless Steel (Fits LSQ Cap)	1
5	300K	Cam Arm Stainless Steel 3" w/Ring	1
6	LSQ200R1	O-Ring for Clean-Out Plug – EPDM	1
6	LSQ200-RV	O-Ring for Clean-Out Plug – FKM (viton type)	1
7	PLUG075S	1" Clean-Out Plug	1
8	LSQ200-C	2" Cap (Fits 1 1/2" & 2" Strainers)	1

The Spray Tech part number can be derived by adding the prefix 'TE' to the listed Banjo part numbers.

BANJO®

3" "Y" Strainers



FEATURES

- Lightweight.
- High volume.
- Constructed of glass filled polypropylene.
- 1/2" drain plug in bottom of cap.
- Reinforced stainless steel screen.
- 3" female NPT threads.
- 75 P.S.I. maximum.*



Easy off strainer ring!

FEATURES

- EPDM gaskets standard FKM (viton type) available.
- Corrosion resistant.
- 200 P.S.I. maximum.
- Clean-out plug.
- Stainless Steel screens sold separately.



3" POLY "Y" STRAINERS

PART NO.	DESCRIPTION	QTY.
LSM300-04	3" Line Strainer With 4 Mesh Screen	2/Box
LSM300-08	3" Line Strainer With 8 Mesh Screen	2/Box
LSM300-12	3" Line Strainer With 12 Mesh Screen	2/Box
LSM300-20	3" Line Strainer With 20 Mesh Screen	2/Box
LSM300-50	3" Line Strainer With 50 Mesh Screen	2/Box

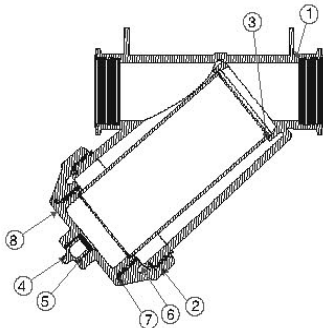

REPLACEMENT PARTS 3" POLY "Y" STRAINERS			
ITEM	PART NO.	DESCRIPTION	QTY.
1	MLS300B1	3" Strainer Body	1
2	MLS300CAP	3" Strainer Cap	1
3	LS304	4 Mesh Screen (Fits 3" Strainer)	1
3	LS308	8 Mesh Screen (Fits 3" Strainer)	1
3	LS312	12 Mesh Screen (Fits 3" Strainer)	1
3	LS320	20 Mesh Screen (Fits 3" Strainer)	1
3	LS350	50 Mesh Screen (Fits 3" Strainer)	1
4	13777	Clean-Out Plug - 1/2"	1
5	13778	O-Ring Clean Out Plug-EPDM	1
6	MLS300-G	3" MLS EPDM Cap Gasket	1
7	MLS300ECG	End Cap Gasket	1
8	LS300EC	End Cap Only (Plug Sold Separately)	1

*WARNING: 3" Polypropylene "Y" Strainer to be used on suction side or non-pressure side in all applications.

3" 316 STAINLESS STEEL "Y" STRAINERS

PART NO.	DESCRIPTION	QTY.
LSS300-BC	3" S.S. Line Strainer Body, Cap and Gaskets	1
LSS300-B	3" S.S. Line Strainer Body	1
LSS300-C	3" S.S. Line Strainer Cap	1
LSS300-S	Screen Seal	2
LSS300-SV	Screen Seal FKM (viton type)	2
LSS300-G	Replacement Gasket-Cap/EPDM	1
LSS300-GV	Replacement Gasket-Cap FKM (viton type)	1
LSS300-H	Handle/Clamp Assembly	1

NOTE: Screens Sold Separately.

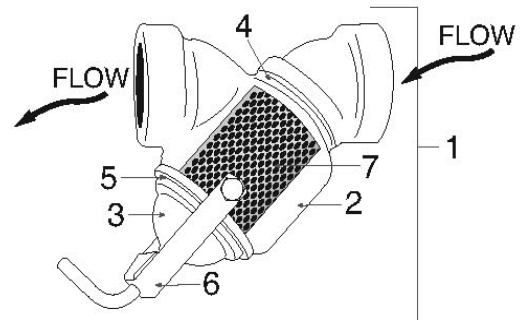

REPLACEMENT PARTS 3" STAINLESS STEEL "Y" STRAINERS			
ITEM	PART NO.	DESCRIPTION	QTY.
1	LSS300-BC	3" S.S. Line Strainer Body, Cap and Gaskets (Screen Sold Sep)	1
2	LSS300-B	3" S.S. Line Strainer Body	1
3	LSS300-C	3" S.S. Line Strainer Cap	1
4	LSS300-S	Screen Seal	2
4	LSS300-SV	Screen Seal FKM (viton type)	2
5	LSS300-G	Replacement Gasket for Cap EPDM	1
5	LSS300-GV	Replacement Gasket for Cap FKM (viton type)	1
6	LSS300-H	Handle/Clamp Assembly	1
7	LSS308	8 Mesh Screen S.S.	1
7	LSS312	12 Mesh Screen S.S.	1
7	LSS320	20 Mesh Screen S.S.	1
7	LSS330	30 Mesh Screen S.S.	1
7	LSS350	50 Mesh Screen S.S.	1



The Spray Tech part number can be derived by adding the prefix 'TE' to the listed Banjo part numbers.

BANJO[®]

Manifold Line Strainers



FEATURES

- EPDM Gaskets.
- 304 Stainless Steel Screens.
- 75 P.S.I. maximum.

Threaded end cap to remove screen

Easy off threaded strainer ring!

3" MANIFOLD LINE "Y" STRAINERS

PART NO.	DESCRIPTION	MAX PSI
MLS300 04	3" Manifold Line Strainer with 4 Mesh Screen	100
MLS300 08	3" Manifold Line Strainer with 8 Mesh Screen	100
MLS300 12	3" Manifold Line Strainer with 12 Mesh Screen	100
MLS300 20	3" Manifold Line Strainer with 20 Mesh Screen	100
MLS300 50	3" Manifold Line Strainer with 50 Mesh Screen	100



FEATURES

- EPDM Gaskets.
- 316 Stainless Steel Screens.
- 150 P.S.I. maximum.

Easy off threaded strainer ring!

MANIFOLD 2" FULL PORT "Y" STRAINERS

PART NO.	DESCRIPTION	MAX PSI
MLS222BC	2" Full Port Flanged Body and Cap	150
MLS222 04	2" Full Port Flanged "Y" Strainer with 4 Mesh Screen	150
MLS222 08	2" Full Port Flanged "Y" Strainer with 8 Mesh Screen	150
MLS222 10	2" Full Port Flanged "Y" Strainer with 10 Mesh Screen	150
MLS222 16	2" Full Port Flanged "Y" Strainer with 16 Mesh Screen	150
MLS222 30	2" Full Port Flanged "Y" Strainer with 30 Mesh Screen	150
MLS222 50	2" Full Port Flanged "Y" Strainer with 50 Mesh Screen	150
MLS222 80	2" Full Port Flanged "Y" Strainer with 80 Mesh Screen	150
MLS222 100	2" Full Port Flanged "Y" Strainer with 100 Mesh Screen	150



The Spray Tech part number can be derived by adding the prefix 'TE' to the listed Banjo part numbers.



MANIFOLD LINE STRAINER REPLACEMENT PARTS

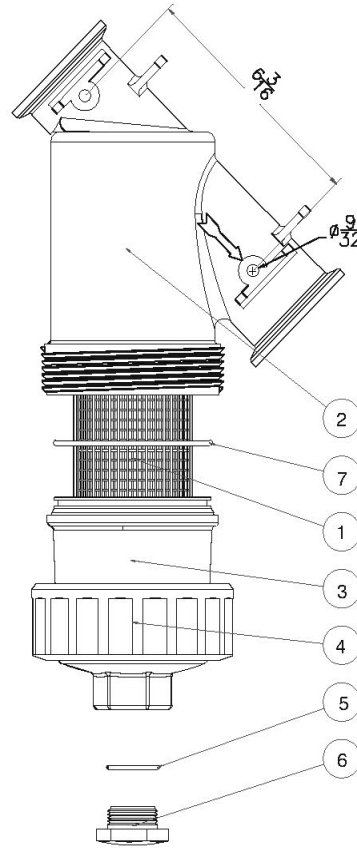
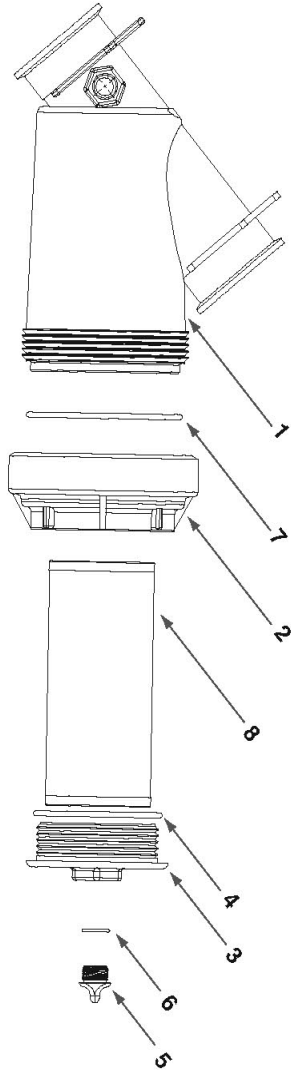

REPLACEMENT PARTS - MLS300			
ITEM	PART NO.	DESCRIPTION	QTY.
1	MLS300B	3" Manifold Strainer Body	1
2	MLS300CAP	3" Strainer Cap	1
3	LS300EC	End Cap	1
4	LS300ECG	3" Strainer End Cap Gasket	1
5	13777	3" Strainer End Cap Plug	1
6	13778	3" Strainer End Cap Plug Gasket	1
7	MLS300G	3" Strainer Cap Gasket	1
8	LS304	3" 4 Mesh Line Strainer Screen	1
8	LS306	3" 6 Mesh Line Strainer Screen	1
8	LS308	3" 8 Mesh Line Strainer Screen	1
8	LS312	3" 12 Mesh Line Strainer Screen	1
8	LS320	3" 20 Mesh Line Strainer Screen	1
8	LS350	3" 50 Mesh Line Strainer Screen	1

REPLACEMENT PARTS - MLS220			
ITEM	PART NO.	DESCRIPTION	QTY.
1	LST204SS	316SS 4 Mesh Strainer Screen	1
1	LST206SS	316SS 6 Mesh Strainer Screen	1
1	LST208SS	316SS 8 Mesh Strainer Screen	1
1	LST210SS	316SS 10 Mesh Strainer Screen	1
1	LST216SS	316SS 16 Mesh Strainer Screen	1
1	LST230SS	316SS 30 Mesh Strainer Screen	1
1	LST250SS	316SS 50 Mesh Strainer Screen	1
1	LST280SS	316SS 80 Mesh Strainer Screen	1
1	LST2100SS	316SS 100 Mesh Strainer Screen	1
2	MLS220B1	Strainer Body	1
3	MLS220C1	Strainer Cap	1
4	MLS220R1	Strainer Ring	1
5	LSQ200R	Plug Gasket	1
6	LSQ200PL	Plug	1
7	MLS220G1	Body Gasket	1
2-7	MLS220BC	Complete Strainer Less Screen	1

The Spray Tech part number can be derived by adding the prefix 'TE' to the listed Banjo part numbers.

BANJO®

Manifold Line Strainers



FEATURES

- EPDM Gaskets.
- 316 Stainless Steel Screens.
- 150 P.S.I. maximum.

MANIFOLD 2" "Y" STRAINERS

PART NO.	DESCRIPTION	MAX PSI
MLS200BC	2" Standard Port Flanged "Y" Strainer Body and Cap	150
MLS200 06	2" Standard Port Flanged "Y" Strainer with 6 Mesh poly scr.	150
MLS200 12	2" Standard Port Flanged "Y" Strainer with 12 Mesh	150
MLS200 20	2" Standard Port Flanged "Y" Strainer with 20 Mesh	150
MLS200 30	2" Standard Port Flanged "Y" Strainer with 30 Mesh	150
MLS200 50	2" Standard Port Flanged "Y" Strainer with 50 Mesh	150
MLS200 80	2" Standard Port Flanged "Y" Strainer with 80 Mesh	150
MLS200 100	2" Standard Port Flanged "Y" Strainer with 100 Mesh	150
MLS200 120	2" Standard Port Flanged "Y" Strainer with 120 Mesh	150



FEATURES

- EPDM Gaskets.
- 316 Stainless Steel Screens.
- 150 P.S.I. maximum.

MANIFOLD 1" "Y" STRAINERS

PART NO.	DESCRIPTION	MAX PSI
MLS100 20	1" Standard Port Flanged "Y" Strainer with 20 Mesh	150
MLS100 40	1" Standard Port Flanged "Y" Strainer with 40 Mesh	150
MLS100 80	1" Standard Port Flanged "Y" Strainer with 80 Mesh	150



FEATURES

- EPDM Gaskets.
- 316 Stainless Steel Screens.
- 150 P.S.I. maximum.

MANIFOLD 1" & 2" STANDARD PORT "T" STRAINERS

PART NO.	DESCRIPTION	MAX PSI
MLST100 16	1" Flanged "T" Strainer 16 Mesh	150
MLST100 30	1" Flanged "T" Strainer 30 Mesh	150
MLST100 50	1" Flanged "T" Strainer 50 Mesh	150
MLST100 80	1" Flanged "T" Strainer 80 Mesh	150
MLST100 100	1" Flanged "T" Strainer 100 Mesh	150
MLST150 16	2" Standard Port "T" Strainer 16 Mesh	150
MLST150 30	2" Standard Port "T" Strainer 30 Mesh	150
MLST150 50	2" Standard Port "T" Strainer 50 Mesh	150
MLST150 80	2" Standard Port "T" Strainer 80 Mesh	150
MLST150 100	2" Standard Port "T" Strainer 100 Mesh	150



The Spray Tech part number can be derived by adding the prefix 'TE' to the listed Banjo part numbers.



MANIFOLD LINE STRAINER REPLACEMENT PARTS

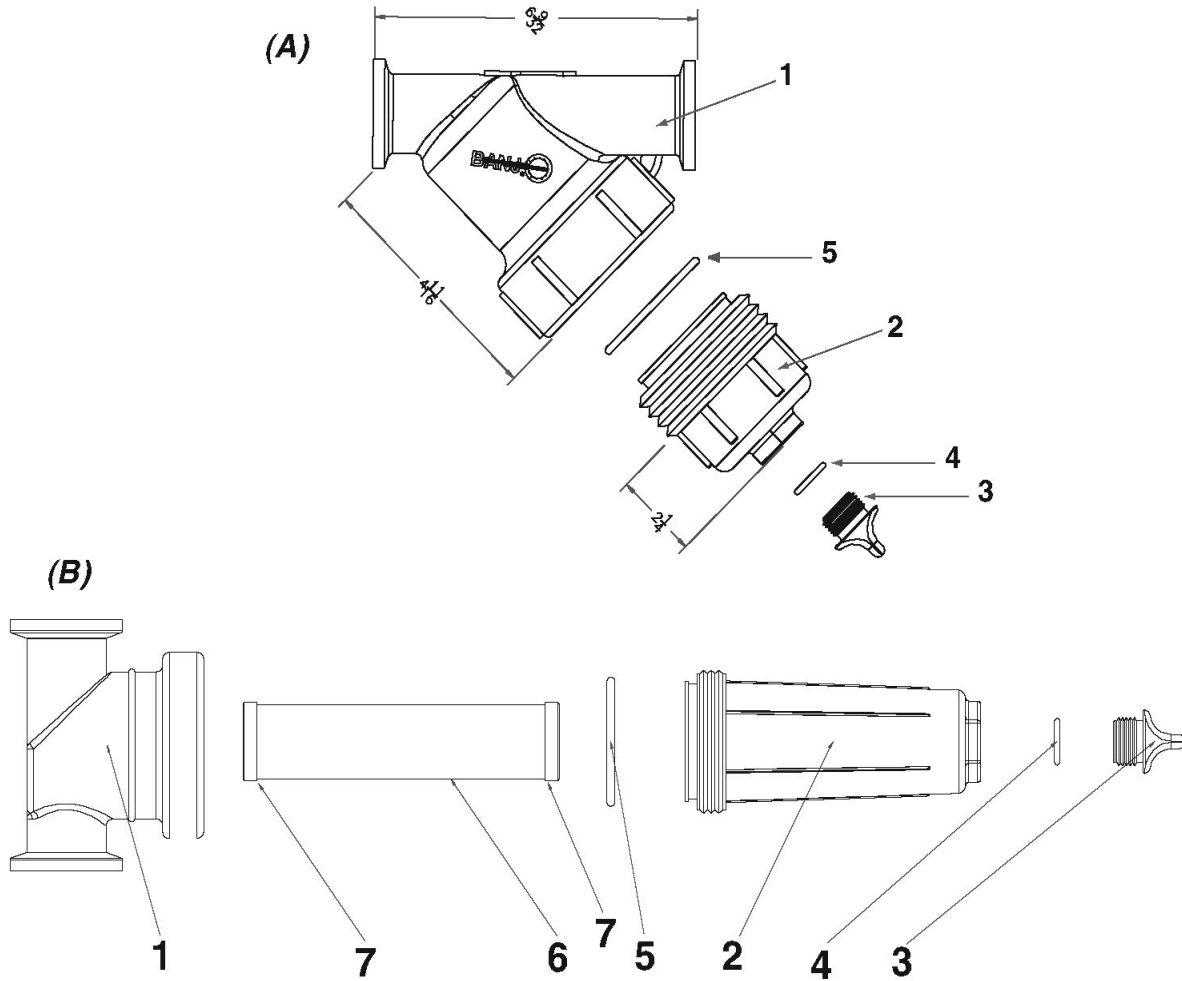

REPLACEMENT PARTS - MLS200 (A)			
ITEM	PART NO.	DESCRIPTION	QTY.
1	MLS200B	2" SP Manifold Strainer Body	1
2	LS150-C	2" SP Strainer Cap, Drain Plug, O-ring	1
3	LSQ200-PL	Plug	1
4	LSQ200-R	O-Ring	1
5	LS150-G	2" SP EPDM Gasket	1
5	LS150-GV	2" SP FKM (viton type) Gasket	1
7	LS141G	EPDM O-Ring (Fits 1 1/2" & 2" Screens)	1
N/S*	LS206	2" 6 All Poly Mesh Line Strainer Screen	1
N/S*	LS212	2" 12 Mesh Line Strainer Screen	1
N/S*	LS220	2" 20 Mesh Line Strainer Screen	1
N/S*	LS230	2" 30 Mesh Line Strainer Screen	1
N/S*	LS250	2" 50 Mesh Line Strainer Screen	1
N/S*	LS280	2" 80 Mesh Line Strainer Screen	1
N/S*	LS2100	2" 100 Mesh Line Strainer Screen	1
N/S*	LS2120	2" 120 Mesh Line Strainer Screen	1

REPLACEMENT PARTS - MLST100-MLST150(B)			
ITEM	PART NO.	DESCRIPTION	QTY.
1	MLST100-H	1" Flanged "T" Strainer Head	1
1	MLST150-H	1 1/2" Flanged "T" Strainer Head	1
2	LST100-B	1" "T" Strainer Bowl, Drain Plug, O-ring	1
2	LST150-B	1 1/2" "T" Strainer Bowl, Drain Plug, O-ring	1
3	12777	Plug for 1" Manifold "T" Strainer	1
3	LSQ200-PL	Plug for 1 1/2" Manifold "T" Strainer	1
4	UV15163	O-Ring for 1" Manifold "T" Strainer	1
4	LSQ200-R	O-Ring for 1 1/2" Manifold "T" Strainer	1
5	LST100-G	EPDM Gasket for 1"	1
5	LST150-G	EPDM Gasket for 1 1/2"	1
5	LST100-GV	FKM (viton type) Gasket for 1"	1
5	LST150-GV	FKM (viton type) Gasket for 1 1/2"	1
6	LST116,130,150,180,1100	1" "T" Strainer Screen 16, 30, 50, 80, 100 Mesh Sizes Available	1
6	LST1516, 1530, 1550,1580,15100	1 1/2" "T" Strainer Screen 16, 30, 50, 80, 100 Mesh Sizes Available	1
7	LS141G	EPDM O-Ring (Fits 1 1/2" & 2" Screens)	1
7	LS125G	EPDM O-Ring (Fits 1" & 1 1/4" Screens)	1

The Spray Tech part number can be derived by adding the prefix 'TE' to the listed Banjo part numbers.

Polypropylene Line Strainers

1/4" through 1-1/2" sizes



Specifications

This low-profile strainer features both 1/4" NPT internal and 1/2" NPT external threads. Strainers (Ref. 2, 3, 4 & 5) are available in 1/2", 3/4", 1", 1-1/4" and 1-1/2" NPT internal threads.

The cap and bowl are available in black polypropylene. Screens come in 20, 50 or 80-mesh stainless steel. EPDM gaskets are standard.

Ratings: 80 psi at 70° F.

Installation

In most circumstances, install the line strainer on the inlet side of the pump. If using a centrifugal pump, a strainer can be installed on either the inlet or discharge side, depending on the strainer flow capacity, strainer pressure rating and other installation factors. The arrow molded in the strainer cap indicates flow of liquid.

Clean the strainer without removing it from the line. Simply unscrew the bowl from the cap and take out the screen. Next, flush the sediment from the screen. Reassemble the strainer by first fitting the screen to the flange in the bowl. Turn the bowl hand tight, which provides a sufficient seal against the cap. **NOTE: Not recommended for fatigue-loading applications such as water softeners.**

Dimensions (In Inches)

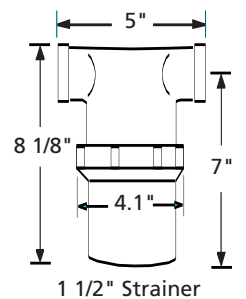
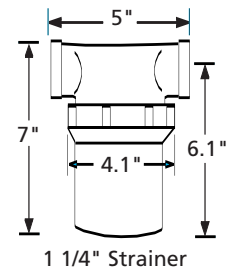
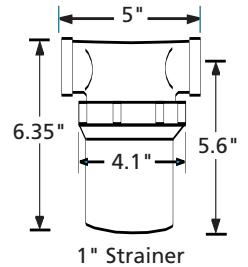
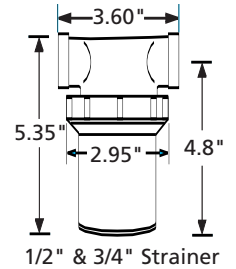
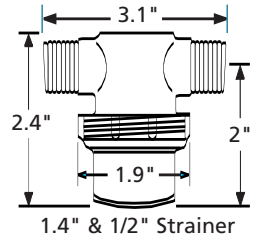

Line Strainer Data								
NPT Number	Model Threads	Screen	Gasket	Open Area (sq. in.)	Parts List			
					Cap	Bowl	Screen	Gasket
1/4" I.D. & 1/2" O.D.	3350-0085A	20 SS	EPDM	2.17	3351-0035	3351-0036	3800-0048	1700-0090
	3350-0079A	50 SS	EPDM	1.75	3351-0035	3351-0036	3800-0046	1700-0090
	3350-0082A	80 SS	EPDM	1.34	3351-0035	3351-0036	3800-0047	1700-0090
1/2"	3350-0056A	20 SS	EPDM	9.6	3351-0037	3351-0039	3800-0029	1700-0091
	3350-0046A	50 SS	EPDM	7.7	3351-0037	3351-0039	3800-0025	1700-0091
	3350-0043A	80 on 20 SS	EPDM	5.9	3351-0037	3351-0039	3800-0026	1700-0091
3/4"	3350-0040A	20 SS	EPDM	9.6	3351-0038	3351-0039	3800-0029	1700-0091
	3350-0040A	50 SS	EPDM	7.7	3351-0038	3351-0039	3800-0025	1700-0091
	3350-0035A	80 on 20 SS	EPDM	5.9	3351-0038	3351-0039	3800-0026	1700-0091
1"	3350-0057A	20 SS	EPDM	16.8	3351-0040	3351-0043	3800-0040	1700-0092
	3350-0058A	50 SS	EPDM	13.5	3351-0040	3351-0043	3800-0041	1700-0092
	3350-0059A	80 on 20 SS	EPDM	10.0	3351-0040	3351-0043	3800-0042	1700-0092
1-1/4"	3350-0071A	20 SS	EPDM	18.0	3351-0041	3351-0043	3800-0043	1700-0092
	3350-0072A	50 SS	EPDM	14.5	3351-0041	3351-0043	3800-0044	1700-0092
	3350-0073A	80 on 20 SS	EPDM	11.0	3351-0041	3351-0043	3800-0045	1700-0092
1-1/2"	3350-0112A	20 SS	EPDM	20.0	3351-0042	3351-0043	3800-0065	1700-0092
	3350-0113A	50 SS	EPDM	16.4	3351-0042	3351-0043	3800-0066	1700-0092
	3350-0114A	80 on 20 SS	EPDM	12.4	3351-0042	3351-0043	3800-0067	1700-0092

Spray Tech part numbers for HYPRO strainers and parts will have the prefix "HY" in front of the above listed Hypro numbers. Spray Tech recommends the Hypro strainer line as an economical replacement for the now discontinued McNally strainer line.

Nylon Line Strainers

1/4" through 1-1/2" sizes



Specifications

This low-profile strainer features both 1/4" NPT internal and 1/2" NPT external threads. A clear polyamide bowl allows for visual inspection without disassembly.

Strainers (Ref. 2, 3, 4 & 5) are available in 1/2", 3/4", 1", 1-1/4" and 1-1/2" NPT internal threads. A white bowl is standard and a clear polyamide bowl is optional.

The cap and bowl are made of nylon 6. (Designate the optional clear polyamide bowl by adding a "P" suffix to the model number.) Screens come in 20, 50 or 80-mesh stainless steel. Buna-N or Viton gaskets are available.

Ratings: 150 psi at 70° F, 100 psi at 125° F. (140° F is the maximum temperature.)

Installation

In most circumstances, install the line strainer on the inlet side of the pump. If using a centrifugal pump, a strainer can be installed on either the inlet or discharge side, depending on the strainer flow capacity, strainer pressure rating and other installation factors. The arrow molded in the strainer cap indicates flow of liquid.

NOTE: The clear polyamide bowl is not recommended for use with alcohol.

Clean the strainer without removing it from the line. Simply unscrew the bowl from the cap and take out the screen. Next, flush the sediment from the screen. Reassemble the strainer by first fitting the screen to the flange in the bowl. Turn the bowl hand tight, which provides a sufficient seal against the cap. **NOTE: Not recommended for fatigue-loading applications such as water softeners.**

Dimensions (in inches)

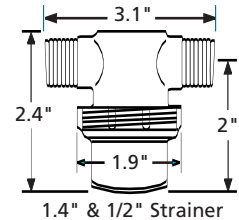

1.4" & 1/2" Strainer

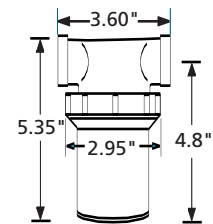

1/2" & 3/4" Strainer

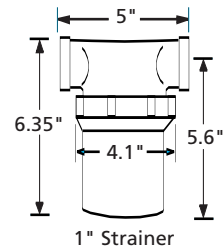

1" Strainer

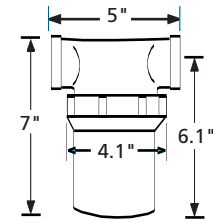

1 1/4" Strainer

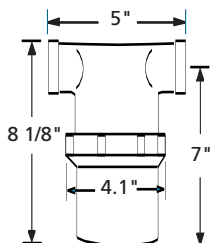

1 1/2" Strainer

Line Strainer Data									
NPT Threads	Model Number	Screen	Gasket	Open Area	Parts List				
					Cap	Bowl	Screen	Gasket	
1/4" I.D. and 1/2" O.D.	3350-0085	20 SS	Buna-N	2.17 sq. in.	3351-0022	3351-0020	3800-0048	1700-0064	
	3350-0085F	20 SS	Viton	2.17 sq. in.	3351-0022	3351-0020	3800-0048	1700-0065	
	3350-0079	50 SS	Buna-N	1.75 sq. in.	3351-0022	3351-0020	3800-0046	1700-0064	
	3350-0079F	50 SS	Viton	1.75 sq. in.	3351-0022	3351-0020	3800-0046	1700-0065	
	3350-0082	80 SS	Buna-N	1.34 sq. in.	3351-0022	3351-0020	3800-0047	1700-0064	
	3350-0082F	80 SS	Viton	1.34 sq. in.	3351-0022	3351-0020	3800-0047	1700-0065	
1/2"	3350-0131	20 SS	Viton	9.6 sq. in.	3351-0007		3800-0029	1700-0045	
	3350-0056	20 SS	Buna-N	9.6 sq. in.	3351-0007	Clear Bowl	3800-0029	1700-0044	
	3350-0046	50 SS	Buna-N	7.7 sq. in.	3351-0007	3351-0015	3800-0025	1700-0044	
	3350-0042	50 SS	Viton	7.7 sq. in.	3351-0007	White Bowl	3800-0025	1700-0045	
	3350-0043	80 on 20 SS	Buna-N	5.9 sq. in.	3351-0007	3351-0005	3800-0026	1700-0044	
	3350-0068	80 on 20 SS	Viton	5.9 sq. in.	3351-0007	3351-0005	3800-0026	1700-0045	
3/4"	3350-0132	20 SS	Viton	9.6 sq. in.	3351-0006		3800-0029	1700-0045	
	3350-0040	20 SS	Buna-N	9.26 sq. in.	3351-0006	Clear Bowl	3800-0029	1700-0044	
	3350-0034	50 SS	Buna-N	7.7 sq. in.	3351-0006	3351-0015	3800-0025	1700-0044	
	3350-0044	50 SS	Viton	7.7 sq. in.	3351-0006	White Bowl	3800-0025	1700-0045	
	3350-0035	80 on 20 SS	Buna-N	5.9 sq. in.	3351-0006	3351-0005	3800-0026	1700-0044	
	3350-0045	80 on 20 SS	Viton	5.9 sq. in.	3351-0006	3351-0005	3800-0026	1700-0045	
1"	3350-0057	20 SS	Buna-N	16.8 sq. in.	3351-0014		3800-0040	1700-0057	
	3350-0060	20 SS	Viton	16.8 sq. in.	3351-0014	Clear Bowl	3800-0040	1700-0058	
	3350-0058	50 SS	Buna-N	13.5 sq. in.	3351-0014	3351-0024	3800-0041	1700-0057	
	3350-0061	50 SS	Viton	13.5 sq. in.	3351-0014	White Bowl	3800-0041	1700-0058	
	3350-0059	80 on 20 SS	Buna-N	10 sq. in.	3351-0014	3351-0013	3800-0042	1700-0057	
	3350-0062	80 on 20 SS	Viton	10 sq. in.	3351-0014	3351-0013	3800-0042	1700-0058	
1-1/4"	3350-0071	20 SS	Buna-N	18 sq. in.	3351-0016		3800-0043	1700-0057	
	3350-0074	20 SS	Viton	18 sq. in.	3351-0016	Clear Bowl	3800-0043	1700-0058	
	3350-0072	50 SS	Buna-N	14.5 sq. in.	3351-0016	3351-0024	3800-0044	1700-0057	
	3350-0075	50 SS	Viton	14.5 sq. in.	3351-0016	White Bowl	3800-0044	1700-0058	
	3350-0073	80 on 20 SS	Buna-N	11 sq. in.	3351-0016	3351-0013	3800-0045	1700-0057	
	3350-0076	80 on 20 SS	Viton	11 sq. in.	3351-0016	3351-0013	3800-0045	1700-0058	
1-1/2"	3350-0112	20 SS	Buna-N	20.8 sq. in.	3351-0026		3800-0065	1700-0057	
	3350-0115	20 SS	Viton	20.8 sq. in.	3351-0026	Clear Bowl	3800-0065	1700-0058	
	3350-0113	50 SS	Buna-N	16.4 sq. in.	3351-0026	3351-0024	3800-0066	1700-0057	
	3350-0116	50 SS	Viton	16.4 sq. in.	3351-0026	White Bowl	3800-0066	1700-0058	
	3350-0114	80 on 20 SS	Buna-N	12.4 sq. in.	3351-0026	3351-0013	3800-0067	1700-0057	
	3350-0117	80 on 20 SS	Viton	12.4 sq. in.	3351-0026	3351-0013	3800-0067	1700-0058	

Spray Tech part numbers for HYPRO strainers and parts will have the prefix "HY" in front of the above listed Hypro numbers. Spray Tech recommends the Hypro strainer line as an economical replacement for the now discontinued McNally strainer line.

Please note that the Hypro Strainer Line now includes **ARAG** polypropylene line strainers. Call Spray Tech for price and availability of ARAG strainers and parts.

PARTS FOR GENERAL FILTER STRAINERS		PARTS FOR McNALLY STRAINERS
GE7507 GE7508 GE7513	Gasket Kit GK-2 Bowl for 3/4" General Filter Center Bolt	The McNally strainer line is discontinued, but some component parts may be available while supplies last. Call Spray Tech for more information.
GE7509 GE7511	Screen, 40 Mesh Screen, 60 Mesh	

Y-LINE STRAINERS

ACCESSORIES



39908 and 39911 Y-TYPE LINE STRAINER

FEATURES

- ◆ O-ring sits on a special chamber to seal against leaking and for easy removal of cap for cleaning.
- ◆ Body configuration turns the liquid flow, the strainer acts as a plumbing elbow and plugs less due to internal flow design.
- ◆ Cap can be removed with the help of a slot in the cap. Use a screwdriver, etc. through the slot to loosen cap.

CONSTRUCTION AND MATERIALS

- ◆ Made of Nylon with Stainless Steel screens and Viton O-rings.
- ◆ A new coarse buttress thread is featured on the cap for ease of installation and removal (two turns only).

Part No.	Inlet/Outlet Size	Screen P/N	Mesh	MAX PSI	O-ring
DE39908-2	3/4"	DE31500-1	40	150	DE31352226
DE39908-5	1"				
DE39911-4	1 1/4"	DE25157	20	75	DE31352234
DE39911-5		DE25156	40		
Recirculating Y-Style Strainers					
DE50560-2	3/4"	DE31500-1	40	150	DE31352226

DELAVAN
Spray Technologies

45992 Y-TYPE LINE STRAINER

FEATURES

- ◆ Low cost strainer that removes contaminants from the line.
- ◆ Easily flushed by removing cap.

CONSTRUCTION AND MATERIALS

- ◆ Made of Glass-filled Polypropylene with Stainless Steel screens and EPDM seals.
- ◆ 45992 should be used only as a suction strainer.



Part No.	Inlet/Outlet Size	Screen P/N	Mesh	MAX PSI	O-ring
DE45992-2	1 1/2"	DE25156	40	75	DE32627237



ACCESSORIES

Y-LINE STRAINERS

Economy Tube-Style Line Strainers

Part No.	Outlet Size	Inlet Size	Screen P/N	Mesh	MAX PSI	Manufacturer
DE2000-1	3/4" mght	3/4" mpt	DE14095-1 DE14095-2	40 80	125	Delavan
SP34Q	3/4" fpt	3/4" fpt	SP4633-4	50	SP4634	Teejet

Suction Strainers and Skimmers

Description	Size (fpt)	Steel Part No.	Polypropylene Part No.	
 Suction Strainer	1 1/2" 2" 3" 4"	GST150RH GST200RH GST300RH GST400RH	GST150P GST200P - -	
 Suction Skimmer	2"	MIBHS200	-	
End-of-Hose Tube-Style Suction Strainers				
	Size	Part No.		Manufacturer
		Strainer	Screen	
Female Thread Connection	3/4"	SP34HSW	SP3910-50 (50 mesh)	Teejet
		DE1700-2	DE31500-1 (40 mesh) DE31500-3 (20 mesh) DE31500-4 (80 mesh)	Delavan
Hose Barb Connection	3/4"	SP7130	SP7139-3SS (50 mesh)	Teejet

VALVES

DIRECTOVALVE ELECTRIC MANIFOLD VALVE ASSEMBLIES

440B MANIFOLD

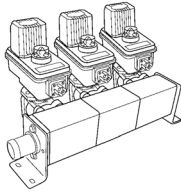

Teejet manifold assemblies are available in several models with a variety of inlet/outlet sizes and configurations. Contact Spray Tech for specific information.

DIRECTOVALVE ELECTRIC VALVES

DIRECTOVALVE BALL VALVES

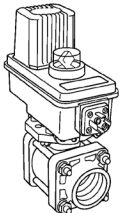

346B

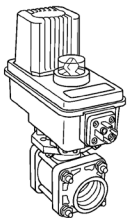

344B

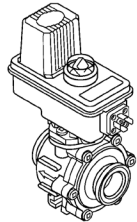

356

Call Spray Tech for part numbers for the different configurations of the 344, 346, and 356 series ball valves. *

*See page 140 for 50 Series Flanges

PRESSURE REGULATING VALVES

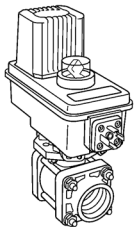

344BR-2
344BRL

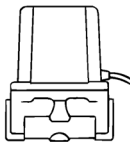

AA244C

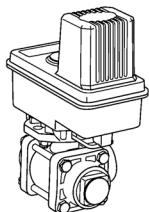

344BPR

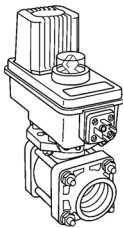

346BR

SP244C 3/4" Nylon Butterfly Regulating Valve

Call Spray Tech for part numbers for the different configurations of the 344, and 346 series regulating valves. *

* See page 140 for flanged fittings

Note: Regulating valves are available in 1, 3 or 6 RPM. PR valve cycle times are double that or R and RL regulating valves

TEEJET ELECTRIC SOLENOID VALVES

DIRECTOVALVE® CONTROL VALVES ELECTRICALLY OPERATED

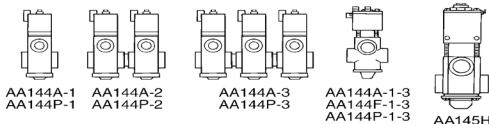

AA144A-1 AA144A-2 AA144A-3 AA144F-1-3 AA144P-1-3 AA145H

SP144A	Poly (100 psi, 10 GPM rating)
SP144A-V	Poly w/Viton seals (100 psi, 10 GPM rating)
SP144A-2	Poly (100 psi, 10 GPM rating)
SP144A-3	Poly (100 psi, 10 GPM rating)
SP144P	Poly (100 psi, 10 GPM rating)
SP144P-3	Poly (100 psi, 10 GPM rating)
SP144A-1-3	Poly (3 way, 65 psi, 8 GPM rating)
SP144F-1-3	Poly (Foam Marker valve - 3 way, 50 psi, 8 GPM rating)
SP145H-1	Nylon (100 psi, 15 GPM rating)

TEEJET ELECTRIC SOLENOID VALVE REPAIR KITS

SP144RK	Old style 144 Kit	SP144ARK	New style 144 Kit
SP144VRK	Old style 144 VITON Kit	SP144AVRK	New style 144 VITON Kit
SP144-13RK	Old style 144-1-3 Kit	SP144PRK	144P Kit
SP144A13RK	New style 144-1-3 Kit	SP145HRK	145 Kit
SP146RK	146 Kit	SP145HVRK	145 VITON Kit

No. 1999A

Solenoid Valve - 18 GPM, 175 PSI, 12 Volt. DC.

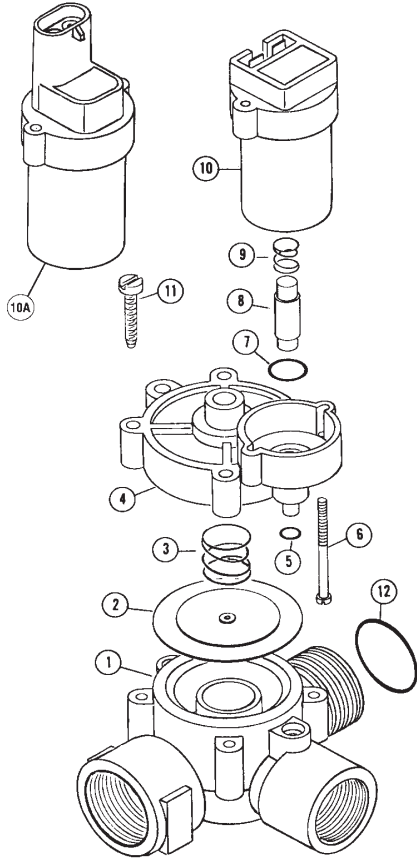

PARTS LIST

Ref.	Part No.	Description	No. Req.
1	1962	Valve Body.....	1
2	*1974	Viton Diaphragm Assembly, Standard	1
2	(1)2109	Aflas Diaphragm Assembly, Optional	1
3	(1)*1975	Spring	1
4	1963	Valve Cover	1
5	(1)*1976	Viton "O" Ring 010	1
6		6-32 x 2 ⁵ / ₈ Screw w/Hex Nut	2
7	(1)*1977	Viton "O" Ring 014	1
8	*2239	Plunger w/Viton Seat, Standard.....	1
8	(1)2240	Plunger w/Aflas Seat, Optional.....	1
9	(1)*1979	Plunger Spring	1
10	2515	Coil Assembly	1
10A	2520	Coil Assembly, Weather Pack	1
11		No. 8 x 1 ¹ / ₂ Screw.....	4
12	2168	"O" Ring 022	1
	2517	Viton Repair Kit – consists of items marked *	
	2518	Aflas Repair Kit – consists of items marked (1)	

SPECIFICATIONS

- Valve HousingGlass Filled Nylon
- Wetted Metal Parts304 and 430 Stainless Steel
- Diaphragm, Seat and Seals.....Viton, Standard, Aflas, Optional
- Coil.....Epoxy Encapsulated
- Terminals.....¼" Male Tabs or Weather Pack
- Voltage.....12 Volt. DC. (Other Available)
- Current.....1.1 AMP at 12 Volt.
- Pressure175 PSI Max., 10 PSI Min.
- Flow.....0-18 GPM 8 CV
- Actuating Pressure.....5 PSI

Spray Tech part numbers for Texas Industrial valves and parts will have the prefix "TI" in front of the above listed Texas Industrial numbers.

Model 2100A Solenoid Valve

10 GPM 125 PSI 12 Volt

PARTS LIST

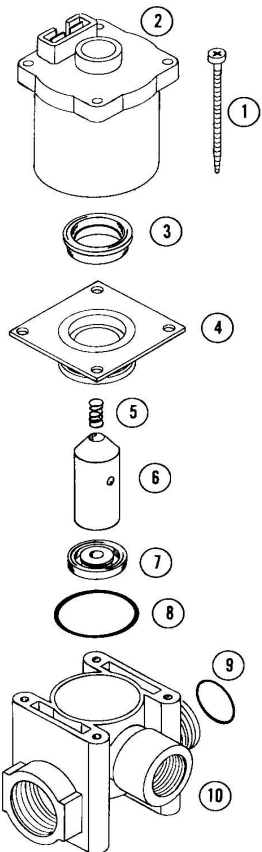

Ref.	Part No.	Description	No. Req.
1		No. 8 x 3 Screw	4
2	2140	Coil	1
3	*2251	Aflas Lip Seal, Optional	1
3	°2254	Viton Lip Seal, Standard	1
4	2349	Base Plate	1
5	*°2176	Spring	1
6	2092	Plunger	1
7	*2121	Seal, Compound TIR, Optional	1
7	°2093	Seal, Viton, Standard	1
8	*°2339	"O" Ring, 024 Viton	1
9	2166	"O" Ring, 018	1
10	2351	Body	1
	2252	Aflas Repair Kit. Consists of items marked with *.	
	2255	Viton Repair Kit. Consists of items marked with °.	

DISASSEMBLY

It is not necessary to take the valve out of the line to service it. The valve can be disassembled by removing the four No. 8 screws (1). Next pull the coil (2) and the base plate (4). Pull the seal (7) from the plunger (6). Remove the lip seal (3) from the base plate.

ASSEMBLY

The seal can be installed by pressing down on the center of it while rotating it on the plunger (6). Be sure it is properly seated. Next set the plunger in the valve body (10) and place the base plate (4) over it. Carefully slip the lip seal (3) over the plunger and into the groove in the base plate. Coat the base plate groove with light grease. Be sure to install "O" ring (8) and spring (5). Do not over tighten the No. 8 screws.

Spray Tech part numbers for Texas Industrial valves and parts will have the prefix "TI" in front of the above listed Texas Industrial numbers.

No. 2100A Solenoid Valve

SPECIFICATIONS

- Valve HousingGlass Filled Nylon
- Wetted Metal Parts430 Stainless Steel
- Seals and "O" Rings.....Compound TIR, Aflas or Viton
- CoilEpoxy Encapsulated
- Terminals1/4" Male Tabs
- Voltage12 Volt. DC.
- Current2.4 AMP at 12 Volt.
- Operating Pressure125 PSI Maximum
- Flow0-10 G.P.M. 4.5 cv.
- Temperature120°F Maximum

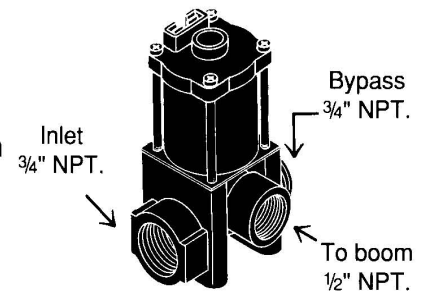

INSTALLATION

The valves can be plumbed as shown in the illustration. It is advisable to install a strainer ahead of the valves. Note the arrows for flow direction.

The coil will radiate heat; therefore, it should not be enclosed. If the coil fails, the valve can be opened by removing the plunger(6).

After usage, always flush and drain valves.

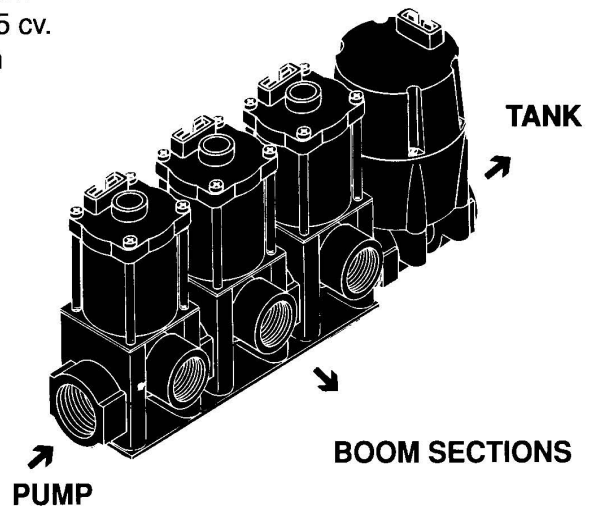

Mounting

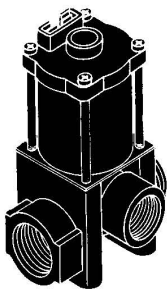

↑ 4 Mounting holes
.17 Dia. x 1.00 Deep
Use No. 10 x 3/4" long screws

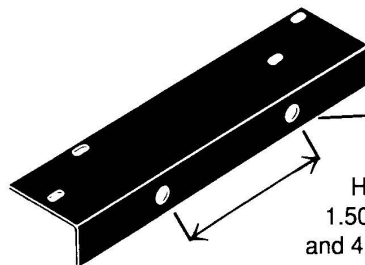

1 1/32 DIA.
Hole Spacing
1.50" for 2148 bracket
and 4.00" for 2149 and 2151 brackets

- 2148 Mounting Bracket for 2100-1 single valve
- 2149 Mounting Bracket for 2100-2 double valves
- 2151 Mounting Bracket for 2100-3 triple valves

Trouble Shooting

Valve fails to open:

1. Check if the coil (2) is burned out.
2. Remove the coil (2) and check if the plunger (6) is stuck.
3. Check the control box and wiring harness for broken wires, bad switches and blown fuses.

Valve fails to shut off:

1. Remove the coil (2) and check if the plunger (6) is stuck.
2. Check if the spring (5) is broken.
3. Check for proper electrical connections.

Model 2202 Solenoid Valve SPECIFICATIONS

- Valve Housing Glass Filled Nylon
- Inlet and Outlet 1/4 NPT.
- Wetted Metal Parts 304 and 430 Stainless Steel
- Seal and "O" Ring Aflas or Viton
- Coil Epoxy Encapsulated
- Terminals 1/4" Male Tabs
- Voltage 12 Volt. DC.
- Current85 AMP at 12 Volt.
- Operating Pressure 50 PSI Maximum
- Flow 0-1 GPM
- Temperature 120°F Maximum

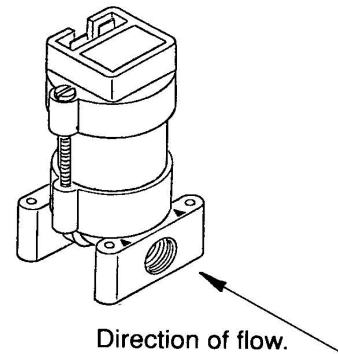

INSTALLATION

It is advisable to install a strainer ahead of the valve. Note the arrows for flow direction.

The coil will radiate heat; therefore, it should not be enclosed. If the coil fails, the valve can be opened by removing the plunger.

After usage, always flush and drain valve.

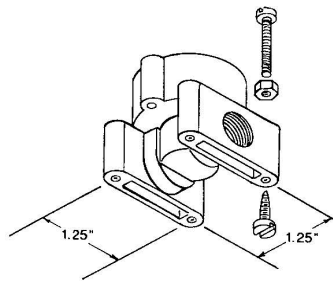

To mount valve use 6-32 screws and nuts or No. 8 self tapping or self threading screws.

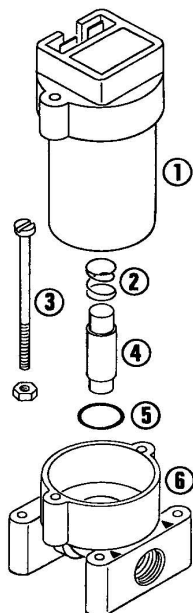

PARTS LIST

Ref.	Part No.	Description	No. Req.
1	2188	Coil	1
2	1979	Spring	1
3		6-32 x 2 Screw w. Hex Nut	2
4	2239	Plunger w/Viton Seat. Black. Standard	1
4	2240	Plunger w/Aflas Seat. Brown. Optional	1
5	1977	"O" Ring, 014 Viton. Black. Standard	1
5	2146	"O" Ring, 014 Aflas. Brown. Optional	1
6	2171	Valve Body. .148 orifice	1

Spray Tech part numbers for Texas Industrial valves and parts will have the prefix "TI" in front of the above listed Texas Industrial numbers.

Model 2204 3 Way Solenoid Valve

SPECIFICATIONS

- Valve Housing Glass Filled Nylon
- Inlet and Outlet..... 1/4" NPT.
- Wetted Metal Parts 304 and 430 Stainless Steel
- Seal and "O" Ring Viton
- Coil..... Epoxy Encapsulated
- Terminals..... 1/4" Male Tabs
- Voltage 12 Volt. DC.
- Current85 AMP at 12 Volt.
- Operating Pressure..... 40 PSI Maximum
- Flow 0-1/2 GPM
- Temperature..... 120°F Maximum

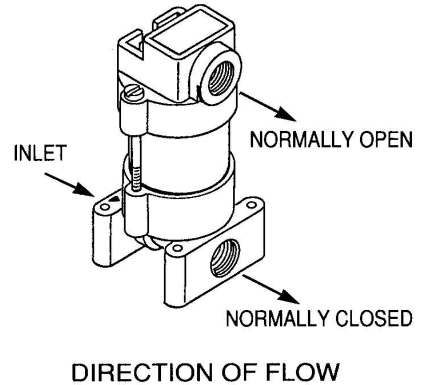

INSTALLATION

It is advisable to install a strainer ahead of the valve. Note the arrows for flow direction.

The coil will radiate heat; therefore, it should not be enclosed.

After usage, always flush and drain valve.

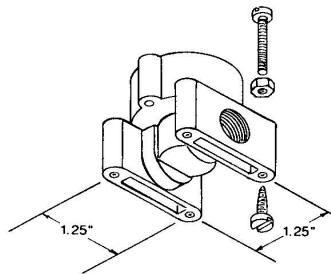

To mount valve use 6-32 screws and nuts or No. 8 self tapping or self threading screws.

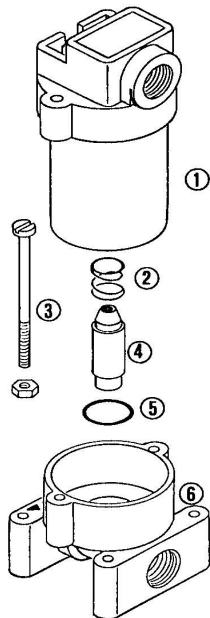

PARTS LIST

Ref.	Part No.	Description	No. Req.
1	2263	Coil.....	1
2	1979	Spring.....	1
3		6-32 x 2 Screw w. Hex Nut.....	2
4	2264	Plunger w/Viton Seat.	1
5	1977	"O" Ring, 014 Viton.	1
6	2241	Valve Body. .105 orifice	1

Model 2500A Electric Boom Valve

10 GPM 100 PSI 12 Volt

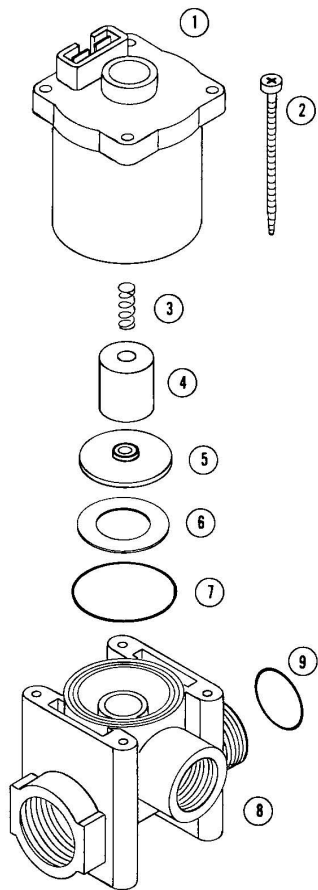

PARTS LIST

Ref.	Part No.	Description	No. Req.
1	2384	Coil.....	1
2		No. 8 x 2 1/2 Screw	4
3	*2315	Spring.....	1
4	2383	Plunger.....	1
5	*2307	Disc Valve Viton	1
6	*2363	Washer.....	1
7	*2314	"O" Ring, 028 Viton	1
8	2385	Valve Body.....	1
9	2166	"O" Ring, 018	1
	2352	Repair Kit. Consists of items marked with *.	

DISASSEMBLY

It is not necessary to take the valve out of the line to service it. The valve can be disassembled by removing the four No. 8 x 2 1/2 screws (2).

ASSEMBLY

Assemble the valve as shown in the illustration. Be sure the small seat on the disc valve (5) is in the up position. Do not over tighten the No. 8 x 2 1/2 screws.

No. 2500A Solenoid Valve

SPECIFICATIONS

- Valve HousingGlass Filled Nylon
- Wetted Metal Parts430 Stainless Steel
- Seal and "O" RingsViton
- CoilEpoxy Encapsulated
- Terminals $\frac{1}{4}$ " Male Tabs
- Voltage12 Volt. DC.
- Current1.7 AMP at 12 Volt.
- Operating Pressure100 PSI Maximum
- Flow0-10 G.P.M. 4.47 cv.
- Temperature120°F Maximum

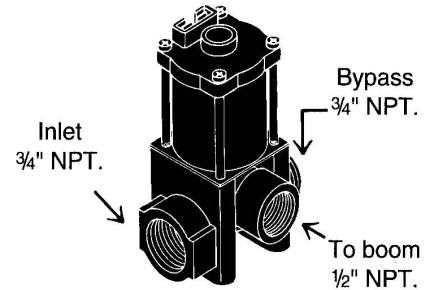

INSTALLATION

The valves can be plumbed as shown in the illustration. It is advisable to install a strainer ahead of the valves. Note the arrows for flow direction.

The coil will radiate heat; therefore, it should not be enclosed. If the coil fails, the valve can be opened by removing the plunger(4).

After usage, always flush and drain valves.

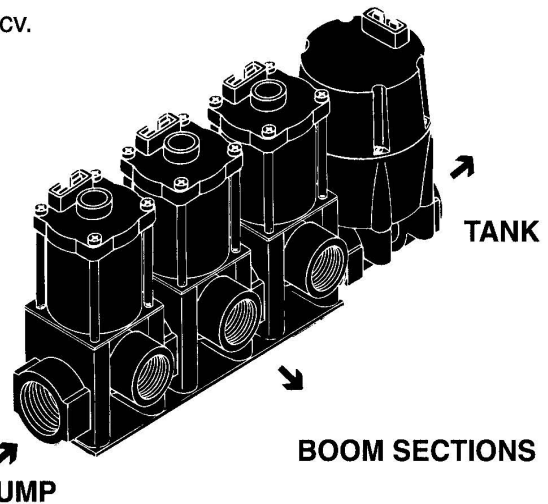

Mounting

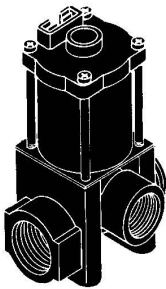

↑ 4 Mounting holes
 $.17$ Dia. x 1.00 Deep
 Use No. 10 x $\frac{3}{4}$ " long screws

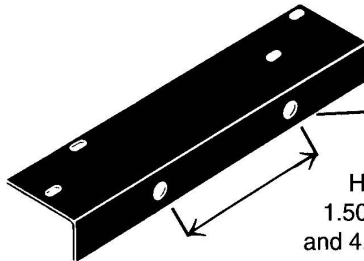

$\frac{11}{32}$ DIA.
 Hole Spacing
 1.50 " for 2148 bracket
 and 4.00 " for 2149 and 2151 brackets

MOUNTING BRACKETS ARE NOT INCLUDED WITH VALVES. THEY MAY BE ORDERED FROM FOLLOWING AS DESIRED:

- 2148 Mounting Bracket for 2500A-1 single valve
- 2149 Mounting Bracket for 2500A-2 double valves
- 2151 Mounting Bracket for 2500A-3 triple valves

Trouble Shooting

Valve fails to open:

1. Check if the coil (1) is burned out.
2. Remove the coil (1) and check if the plunger (4) is stuck.
3. Check the control box and wiring harness for broken wires, bad switches and blown fuses.

Valve fails to shut off:

1. Remove the coil (1) and check if the plunger (4) is stuck.
2. Check if the spring (3) is broken.
3. Check for proper electrical connections.



Electric Motorized Ball Valves

Texas Industrial Remcor, Inc.

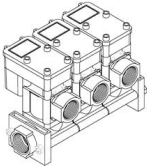
	Part No.	Description
	TI2404-1	20 GPM, 150 PSI, 12-Volt Series 2400 2-way valves have only 5 PSI pressure drop at 20 GPM. Wetted parts are made of glass filled nylon and 303 stainless. Easy to replace Viton face seal. Totally enclosed motor with sealed connector, draws 2.5 Amp. max. Motor is protected by a self resetting fuse. Open and closing time is .8 sec.
	TI2404-3	Same as above, 3-valve bank.







Electric Pressure Regulating Valves

Texas Industrial Remcor, Inc.

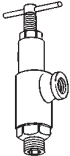
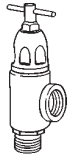
	Part No.	Description
 <p data-bbox="105 1125 469 1297">The model 1560A and 1541A Electric Pressure Regulators are equipped with a precision high torque motor and gear reduction and a high strength body for heavy-duty service. Chemical resistant glass filled nylon body, stainless steel motor shaft and butterfly and Viton seal. Low current draw, 50 MA at 12-volt. Maximum recommended pressure is 150 PSI. Speed at 12 volt = 1 RPM or at 6-volt = .5 RPM.</p>	TI1541 TI1560	1" NPT with 1" orifice. Use for flow rates from 15 to 100 GPM 3/4" NPT with 3/4" orifice and close-tolerance butterfly for use as either by-pass regulator or throttling valve. Use for flow rates up to 50 GPM

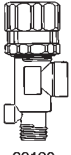
TEEJET MANUAL VALVES

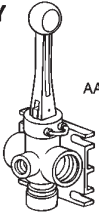
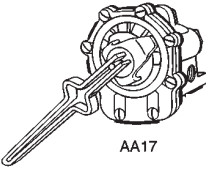
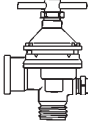
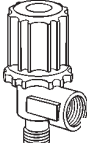
<p style="text-align: center;">PRESSURE RELIEF/ REGULATING VALVES</p> <div style="display: flex; justify-content: space-around;"> <div style="text-align: center;">  6815 </div> <div style="text-align: center;">  AA110 </div> </div> <div style="display: flex; justify-content: space-around; margin-top: 20px;"> <div style="text-align: center;">  8460 </div> <div style="text-align: center;">  23120 </div> </div>	<table style="width: 100%; border-collapse: collapse;"> <tr> <td style="width: 50%; vertical-align: top;"> SP110-14 SP110-14-700 SP110-14-1000 SP110-38 SP110-1 SP110-1-DI SP110114DI SP110112DI </td> <td style="width: 50%; vertical-align: top;"> 1/4" Brass 1/4" Brass (700 psi) 1/4" Brass (1000 psi) 3/8" Brass 1" Brass 1" Ductile Iron 1 1/4" Ductile Iron 1 1/2" Ductile Iron </td> </tr> <tr> <td style="vertical-align: top;"> SP6815-* SP6815-34H SP6815-300 SP6815-700 </td> <td style="vertical-align: top;"> 1/2" or 3/4" Brass (300 psi/20 bar) 1/2" or 3/4" Brass (700 psi/48 bar) 3/4" Brass with Hard S.S. Valve Seats Repair Kit for 6815 (300 psi) Repair Kit for 6815 (700 psi) </td> </tr> <tr> <td style="vertical-align: top;"> SP8460-* SP8460RK SP23120-* SP23120A* SP23120ARK </td> <td style="vertical-align: top;"> Nylon 8460 Repair Kit Polypropylene Polypropylene w/VITON and 316-SS 23120 Repair Kit </td> </tr> </table> <p style="font-size: small;">* 12= 1/2", 34= 3/4"</p>	SP110-14 SP110-14-700 SP110-14-1000 SP110-38 SP110-1 SP110-1-DI SP110114DI SP110112DI	1/4" Brass 1/4" Brass (700 psi) 1/4" Brass (1000 psi) 3/8" Brass 1" Brass 1" Ductile Iron 1 1/4" Ductile Iron 1 1/2" Ductile Iron	SP6815-* SP6815-34H SP6815-300 SP6815-700	1/2" or 3/4" Brass (300 psi/20 bar) 1/2" or 3/4" Brass (700 psi/48 bar) 3/4" Brass with Hard S.S. Valve Seats Repair Kit for 6815 (300 psi) Repair Kit for 6815 (700 psi)	SP8460-* SP8460RK SP23120-* SP23120A* SP23120ARK	Nylon 8460 Repair Kit Polypropylene Polypropylene w/VITON and 316-SS 23120 Repair Kit
SP110-14 SP110-14-700 SP110-14-1000 SP110-38 SP110-1 SP110-1-DI SP110114DI SP110112DI	1/4" Brass 1/4" Brass (700 psi) 1/4" Brass (1000 psi) 3/8" Brass 1" Brass 1" Ductile Iron 1 1/4" Ductile Iron 1 1/2" Ductile Iron						
SP6815-* SP6815-34H SP6815-300 SP6815-700	1/2" or 3/4" Brass (300 psi/20 bar) 1/2" or 3/4" Brass (700 psi/48 bar) 3/4" Brass with Hard S.S. Valve Seats Repair Kit for 6815 (300 psi) Repair Kit for 6815 (700 psi)						
SP8460-* SP8460RK SP23120-* SP23120A* SP23120ARK	Nylon 8460 Repair Kit Polypropylene Polypropylene w/VITON and 316-SS 23120 Repair Kit						
<p style="text-align: center;">Hypro Pressure Relief Valve</p> <div style="text-align: center;">  </div>	<table style="width: 100%; border-collapse: collapse;"> <tr> <td style="width: 50%;">HY3300-16</td> <td style="width: 50%;">3/4" Pressure Relief Valve</td> </tr> </table>	HY3300-16	3/4" Pressure Relief Valve				
HY3300-16	3/4" Pressure Relief Valve						
<p style="text-align: center;">Delavan Pressure Relief Valves</p>	<table style="width: 100%; border-collapse: collapse;"> <tr> <td style="width: 50%;">DE13895-1</td> <td style="width: 50%;">1/2" Pressure Relief Valve.</td> </tr> <tr> <td>DE13895-2</td> <td>3/4" Pressure Relief Valve.</td> </tr> </table>	DE13895-1	1/2" Pressure Relief Valve.	DE13895-2	3/4" Pressure Relief Valve.		
DE13895-1	1/2" Pressure Relief Valve.						
DE13895-2	3/4" Pressure Relief Valve.						
<p style="text-align: center;">DIRECTOVALVE® MANUALLY OPERATED CONTROL VALVE</p> <div style="text-align: center;">  AA6B </div>	<table style="width: 100%; border-collapse: collapse;"> <tr> <td style="width: 50%;">SP6B SP6BRK</td> <td style="width: 50%;">Teejet Manually Operated Control Valve Repair Kit</td> </tr> </table>	SP6B SP6BRK	Teejet Manually Operated Control Valve Repair Kit				
SP6B SP6BRK	Teejet Manually Operated Control Valve Repair Kit						
<p style="text-align: center;">TEEVALVE® MANUAL CONTROL VALVE</p> <div style="text-align: center;">  AA17 </div>	<table style="width: 100%; border-collapse: collapse;"> <tr> <td style="width: 50%;">SP17Y SP17RK</td> <td style="width: 50%;">Teejet aluminum control valve, with 1" Inlet, 3/4" Outlets 17 Series Repair Kit</td> </tr> </table>	SP17Y SP17RK	Teejet aluminum control valve, with 1" Inlet, 3/4" Outlets 17 Series Repair Kit				
SP17Y SP17RK	Teejet aluminum control valve, with 1" Inlet, 3/4" Outlets 17 Series Repair Kit						
<p style="text-align: center;">THROTTLING VALVES</p> <div style="display: flex; justify-content: space-around;"> <div style="text-align: center;">  12690 </div> <div style="text-align: center;">  23520 </div> </div>	<table style="width: 100%; border-collapse: collapse;"> <tr> <td style="width: 50%; vertical-align: top;"> SP12690-34 SP23520-* </td> <td style="width: 50%; vertical-align: top;"> Teejet 3/4" Throttling Valve, Nylon Teejet Throttling Valve, Polypropylene </td> </tr> </table> <p style="font-size: small;">* 12= 1/2", 34= 3/4"</p>	SP12690-34 SP23520-*	Teejet 3/4" Throttling Valve, Nylon Teejet Throttling Valve, Polypropylene				
SP12690-34 SP23520-*	Teejet 3/4" Throttling Valve, Nylon Teejet Throttling Valve, Polypropylene						

	Part Number	Port Size	# of Ports	Max GPM	Unloading Range (PSI)	Cup Material
Hypro Unloader Valves	HY3390-37	1/2"	3	6	300-1000	Buna/Teflon
	HY3390-42	3/4"	3	35	200-400	Buna
	HY3390-51	3/4"	3	15	100-1500	Viton/Teflon
	HY3390-53	3/4"	3	15	1000-2000	Buna
	HY3390-62D	3/8"	3	5	200-600	Buna
	HY3390-63B	3/8"	3	5	400-1000	Buna
	HY3390-67	3/8"	3	5	800-1500	Buna
	HY3390-76	3/8"	3	8	3600	Buna



Polypropylene Bolted Ball Valves

FEATURES

- FKM (viton type) seals.
- Precision molded polypropylene is reinforced with fiberglass for additional strength.
- Self-aligning ball moves freely against the PTFE seats for smooth operation. The valve opens and closes with very little pressure on the handle.
- Ball is diamond turned, after molding, to make it spherically perfect, which provides precise contact between ball and seats.
- PTFE self-lubricating stem bushings and seats cannot stick or bind.



4 BOLT VALVES

PART NO.	DESCRIPTION	MAX PSI	PIPE SIZE	OPENING THRU BALL	QUANTITY
V060	Valve Full Port	150	1/2"	3/4"	24/per box
V075	Valve Full Port	150	3/4"	3/4"	24/per box
V100	Valve Standard Port	150	1"	3/4"	24/per box
V100FP	Valve Full Port	150	1"	1"	24/per box
V125	Valve Standard Port	150	1 1/4"	1"	24/per box
V125FP	Valve Full Port	150	1 1/4"	1 1/2"	24/per box
V150	Valve Full Port	150	1 1/2"	1 1/2"	24/per box
V200	Valve Standard Port	150	2"	1 1/2"	24/per box

STRAIGHT MOUNTING BRACKET

- 304 Stainless Steel

V10270



90° MOUNTING BRACKET

- 304 Stainless Steel

V10271



ACCESSORIES

PART NO.	DESCRIPTION	VALVE USED
VL20153	Locking Device	V125FP, V150 & V200 (Padlock not included)
V25271	90° Mounting Bracket	V150, V200
V25270	Straight Mounting Bracket	V150, V200
V10270	Straight Mounting Bracket	V100FP, V125
V10271	90° Mounting Bracket	V100FP, V125

LOCKING DEVICE FEATURES

- Stainless Steel Construction.
- Installs under valve handle.
- Comes complete with handle and locking device.
- Padlock not included.
- Available for V125FP, V150 and V200.

VL20153



HANDLE RISERS

PART NO.	DESCRIPTION	VALVE USED
V10153138BL	1" X 1 3/8" Handle Offset	V075BL, V100BL
V10153138	1" X 1 3/8" Handle Offset	V100FP, V125, V075SL, V100SL
V20153138BL	2" X 1 3/8" Handle Offset	V125BL, V150BL
V20153138	2" X 1 3/8" Handle Offset	V125FP, V150, V200, V125SL, V150SL
V25153138BL	2" FP X 1 3/8" Handle Offset	MV200BL, MV300BL
V25153138	2" FP X 1 3/8" Handle Offset	V200FP, V200SL



The Spray Tech part number can be derived by adding the prefix 'TE' to the listed Banjo part numbers.

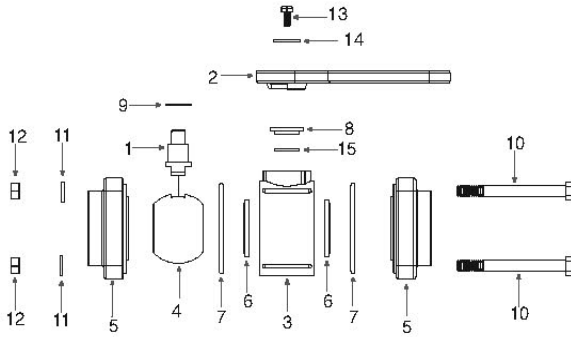

REPLACEMENT PARTS V050 – V075 – V100			
ITEM	PART NO.	DESCRIPTION	QTY.
1	V07151A	Stem	1
2	V10153A	Handle	1
3	V07254	Valve Body	1
4	V07155*	Valve Ball	1
5	V05256	End Plate 1/2"	2
5	V07257	End Plate 3/4"	2
5	V07256	End Plate 1"	2
6	V07258A*	Ball Seat	2
7	V07264*	Valve Body O Ring FKM (viton type)	2
8	V07159*	Upper Stem Bushing	1
9	V07060*	Thrust Washer	1
10	V07017	1/4" x 3" S.S. Body Bolt	4
11	V07018	1/4" S.S. Lock Washer	4
12	V07019	1/4" S.S. Nut	4
13	V10020A	#10 x 3/4" S.S. Handle Bolt	1
14	V07021A	S.S. Handle Washer	1
15	V07163*	Stem O Ring FKM (viton type)	1
N/S	V07200	Valve Repair Kit	1

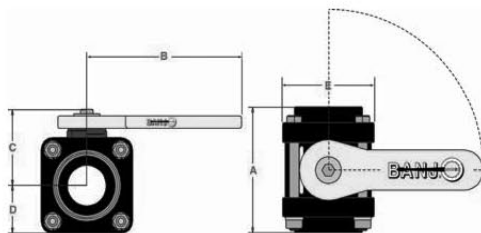

DIMENSION CHART IN INCHES (REFER TO DRAWING ABOVE)

PART NO.	DESCRIPTION	A	B	C	D	E
V050	Valve Full Port	3.44	3.37	2.06	1.25	2.50
V075	Valve Full Port	3.44	3.37	2.06	1.25	2.50
V100	Valve Standard Port	3.44	3.37	2.06	1.25	2.50
V100FP	Valve Full Port	4.19	3.31	2.44	1.81	3.50
V125	Valve Standard Port	4.19	3.31	2.44	1.81	3.50
V125FP	Valve Full Port	4.72	5.90	2.70	1.92	3.50
V150	Valve Full Port	4.72	5.90	2.70	1.92	3.50
V200	Valve Standard Port	4.72	5.90	2.70	1.92	3.50

REPLACEMENT PARTS V100FP – V125			
ITEM	PART NO.	DESCRIPTION	QTY.
1	V10151A	Stem	1
2	V10153A	Handle	1
3	V10254	Valve Body	1
4	V10155*	Valve Ball	1
5	V10257	End Plate 1" Full Port	2
5	V10256	End Plate 1 1/4"	2
6	V10258A*	Ball Seat	2
7	V10264	Valve Body O Ring FKM(viton type)	2
8	V10159*	Upper Stem Bushing	1
9	V10060*	Thrust Washer	1
10	V10117	5/16" x 3 1/2" S.S. Body Bolt	4
11	V10118	5/16" S.S. Lock Washer	4
12	V10119	5/16" S.S. Nut	4
13	V10020A	#10 x 3/4" S.S. Handle Bolt	1
14	V07021A	S.S. Handle Washer	1
15	V10163*	Stem O Ring FKM (viton type)	1
N/S	V10200	Valve Repair Kit	1
N/S	V10270	Straight Mounting Bracket	1
N/S	V10271	90° Mounting Bracket	1

***Valve Repair Kits Contain Items Marked With Asterisk :**

- 1 Ball 2 Body O Rings 1 Thrust Washer
- 2 Ball Seats 1 Upper Stem Bushing 1 Stem O Ring

REPLACEMENT PARTS V125FP – V150 – V200			
ITEM	PART NO.	DESCRIPTION	QTY.
1	V20151M	Stem	1
2	V20153	Handle	1
2	V20353T	T Handle	1
N/S	V20353C	1 1/8" Plug for T Handle (Cap Plug)	1
3	V20254	Valve Body	1
4	V20255A*	Valve Ball	1
5	V20256	2" End Plate	2
5	V20257	1 1/2" End Plate	2
5	V20267	1 1/4" End Plate Full Port	2
6	V20258A*	Ball Seat	2
7	V20264*	Valve Body O Ring FKM (viton type)	2
8	V20159*	Upper Stem Bushing	1
9	V20060*	Thrust Washer	1
10	V20017	3/8" x 4" S.S. Body Bolt	4
11	V20018	3/8" S.S. Lock Washer	4
12	V20019	3/8" S.S. Nut	4
13	V20020	1/4" x 1/2" S.S. Handle Bolt	1
14	V20021	S.S. Handle Washer	1
15	V20163*	Stem O Ring FKM(viton type)	1
N/S	V20200	Valve Repair Kit	1

The Spray Tech part number can be derived by adding the prefix 'TE' to the listed Banjo part numbers.



Polypropylene Bolted Ball Valves

FEATURES

- FKM (viton type) seals.
- PTFE self-lubricating stem bushings and seats cannot stick or bind.
- Precision molded in polypropylene.
- Polypropylene is reinforced with fiberglass for additional strength.
- Self-aligning ball moves freely against the PTFE seats for smooth operation.
- Valve opens and closes with very little pressure on the handle.
- Ball is diamond turned, after molding, to make it spherically perfect, which provides precise contact between ball and seats.



6 BOLT VALVES

PART NO.	DESCRIPTION	MAX PSI	PIPE SIZE	OPENING THRU BALL	QUANTITY
V200FP	Valve Full Port	150	2"	2"	8/per box
V300	Valve Standard Port	100	3"	2½"	8/per box
V300FP	Valve Full Port	100	3"	3"	6/per box
V400	Valve Standard Port	75	4"	3½"	4/per box



VFMT200FP
(shown w/ long handle)

6 BOLT VALVES W/ "F" ADAPTER

PART NO.	DESCRIPTION	MAX PSI	PIPE SIZE	OPENING THRU BALL	QUANTITY
VFMT200FP	Valve Full Port w/"F" Adapter	150	2"	2"	6/per box
VFMT200FPSH	Valve Full Port w/"F" Adapter	150	2"	2"	6/per box

ACCESSORIES

PART NO.	DESCRIPTION	VALVE USED
VL25153	Locking Device	V200FP, V300, V300FP, V400, VFMT200FP, VFMT200FPSH
V25271	90° Mounting Bracket	V200FP, V300, V300FP, V400, VFMT200FP, VFMT200FPSH
V25270	Straight Mounting Bracket	V200FP, V300, V300FP, V400, VFMT200FP, VFMT200FPSH
V25153SH	Short Handle	VFMT200FPSH Only

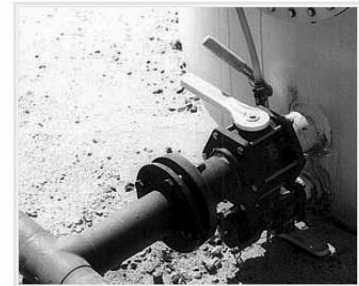

LOCKING HANDLE FEATURES

- Stainless Steel Hardware.
- Locks in open and closed positions.
- Locking handle replaces standard handle.
- Padlock not included.
- Available for valves V200FP, V300, V300FP, V400, VFMT200FP, VFMT200FPSH.



VL25153

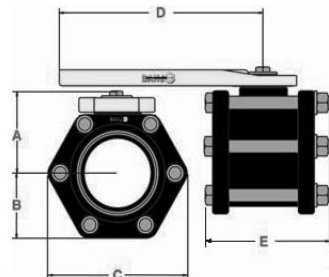

DIMENSION CHART IN INCHES (REFER TO DRAWING ON LEFT)

PART NO.	DESCRIPTION	A	B	C	D	E
V200FP	Valve Full Port	3.25	2.38	5.44	9.25	5.50
V300	Valve Standard	3.53	2.69	6.28	9.25	6.06
V300FP	Valve Full Port	4.25	3.25	7.35	9.25	6.40
V400	Valve Standard Port	4.50	3.60	8.19	9.25	7.88
VFMT200FP	Valve Full Port	3.38	2.38	5.44	9.25	8.30
VFMT200FPSH	Valve Full Port	3.38	2.38	5.44	5.25	8.30



The Spray Tech part number can be derived by adding the prefix 'TE' to the listed Banjo part numbers.

BANJO VALVES

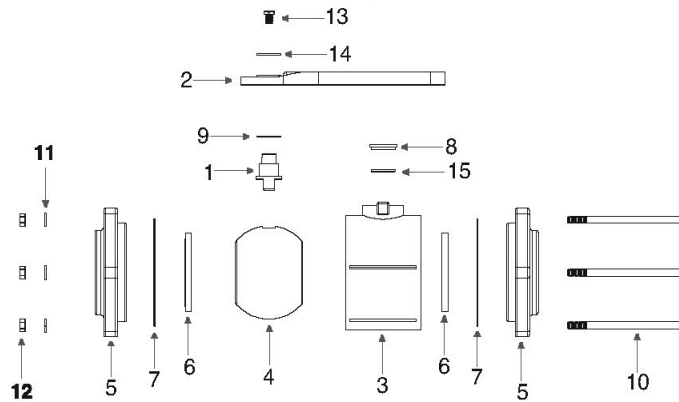

REPLACEMENT PARTS V200FP - VFMT200FP - VFMT200FPSH - V300 - V300FP - V400			
ITEM	PART NO.	DESCRIPTION	QTY.
1	V25151B	Stem	1
2	V25153	Handle	1
8	V25160*	Upper Stem Bushing	1
9	V25060*	Thrust Washer	1
11	V20018	$\frac{3}{8}$ " S.S. Lock Washer	6
12	V20019	$\frac{3}{8}$ " S.S. Nut	6
13	V25020	$\frac{3}{8}$ " x $\frac{1}{2}$ " S.S. Handle Bolt	1
14	V25121	S.S. Handle Washer	1
15	V25163*	Stem O-Ring FKM (Viton Type)	1
N/S	VL25153	Locking Handle (Padlock not included)	1
N/S	V25271	90° Mounting Bracket Fits V150, V200, V200FP, V300 & V300FP	1
N/S	V25270	Straight Mounting Bracket Fits V150, V200, V200FP, V300 & V300FP	1

***Valve Repair Kits Contain Items Marked With Asterisk :**

1 Ball	2 Body O-Rings	1 Thrust Washer
2 Ball Seats	1 Upper Stem Bushing	1 Stem O-Ring

REPLACEMENT PARTS -V300			
ITEM	PART NO.	DESCRIPTION	QTY.
3	V30254	Valve Body	1
4	V30255*	Valve Ball	1
5	V30264	3" End Plate	2
6	V30258A*	Ball Seat	2
7	V30265*	Valve Body O-Ring FKM (Viton Type)	2
10	V30017	$\frac{3}{8}$ " x 5" S.S. Body Bolt	6
N/S	V30200	Valve Repair Kit	1

REPLACEMENT PARTS -V300FP			
ITEM	PART NO.	DESCRIPTION	QTY.
3	V35254	Valve Body	1
4	V35255A*	Valve Ball	1
5	V35264	3" FP End Plate	2
6	V35258A*	Ball Seat	2
7	V35265*	Valve Body O-Ring FKM (Viton Type)	2
10	V35017	$\frac{3}{8}$ " x 6" S.S. Body Bolt	6
N/S	V35200	Valve Repair Kit	1

REPLACEMENT PARTS V200FP - VFMT200FP - VFMT200FPSH			
ITEM	PART NO.	DESCRIPTION	QTY.
5	V25153SH	Short Handle for VFMT200FPSH	1
3	V25254	Valve Body	1
4	V25255A*	Valve Ball	1
5	V25256	End Plate 2" Female NPT	2
5	VMT25256	End Plate 2" Male NPT	1
5	VF25256	End Plate 2" Male Adapter	1
6	V25258A*	Ball Seat	2
7	V25264*	Valve Body O-Ring FKM (Viton Type)	2
10	V25017	$\frac{3}{8}$ " x $4\frac{1}{2}$ " S.S. Body Bolt	6
N/S	V25200	Valve Repair Kit	1

REPLACEMENT PARTS -V400			
ITEM	PART NO.	DESCRIPTION	QTY.
3	V40254	Valve Body	1
4	V40255*	Valve Ball	1
5&6	V40264	End Plate w/PTFE Ball Seat	2
7	V40265*	Valve Body O-Ring FKM (Viton type)	2
10	V40017	$\frac{3}{8}$ " x $7\frac{1}{2}$ " SS Body Bolt	6
N/S	V40200	Valve Repair Kit	1

The Spray Tech part number can be derived by adding the prefix 'TE' to the listed Banjo part numbers.



2" Full Port Polypropylene Bolted Ball Valves

FEATURES

- FKM (viton type) seals.
- Stainless steel bolts.
- PTFE self-lubricating stem bushings and seats cannot stick or bind.
- Precision molded in polypropylene.
- Polypropylene is reinforced with fiberglass for additional strength.
- Self-aligning ball moves freely against the PTFE seats for smooth operation.
- Valve opens and closes with very little pressure on the handle.
- Ball is diamond turned, after molding, to make it spherically perfect, which provides precise contact between ball and seats.
- Maximum operating pressure 150 P.S.I. @70°F & 75 P.S.I. @150°F.



4 BOLT FULL PORT VALVES

PART NO.	DESCRIPTION	MAX PSI	PIPE SIZE	OPENING THRU BALL	QUANTITY
VFMT204FP	2" Valve-Male NPT X Male Adapter	150	2"	2"	6/per box
V204FP	Valve — Full Port	150	2"	2"	8/per box

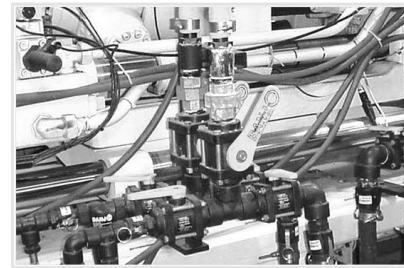

2" Full Port ANSI Flange Ball Valves

FEATURES

- 100% PTFE seats.
- FKM (viton type) Seals.
- Glass-filled polypropylene.
- Unique compact design.
- Lightweight.
- Maximum operating pressure 100 P.S.I. @ 70°F & 75 P.S.I. @150°F.



*** SPECIAL ORDER ITEM ***

ANSI FLANGE 6 BOLT VALVES

PART NO.	DESCRIPTION	MAX PSI	PIPE SIZE	OPENING THRU BALL	QUANTITY
VSF200FFAF	2" Male Adapter X 2" ANSI Flange	100	2"	2"	6/per box
VSMT200FFAF	2" Male NPT X 2" ANSI Flange	100	2"	2"	6/per box
AF200G	2" ANSI Flange Gasket - EPDM	Sold Separately			
AF200GV	2" ANSI Flange Gasket FKM (viton type)	Sold Separately			

ANSI Flange Gasket



The Spray Tech part number can be derived by adding the prefix 'TE' to the listed Banjo part numbers.

BANJO VALVES



REPLACEMENT PARTS -VFMT204FP		
PART NO.	DESCRIPTION	QTY.
VF25356	Male Adapter, End Plate 2" FP Valve	1
VMT25356	MPT End Plate for 4 Bolt 2" FP	1
V20018	3/8" S.S. Lock Washer	4
V20019	3/8" S.S. Body Nut	4
V25017	3/8" x 4 1/2" S.S. Body Bolt	4
V25060	Thrust Bushing	1
V25151B	Stem 2" FP, 3" FP & 4" Machined	1
V25153	Valve Handle for 2 3 & 4" FP	1
V25254	Valve Body 2" FP New Style	1

REPLACEMENT PARTS -V204FP		
PART NO.	DESCRIPTION	QTY.
V25456	2" Full Port 4 Bolt Endplate	2
V20018	3/8" S.S. Lock Washer	4
V20019	3/8" S.S. Body Nut	4
V25017	3/8" x 4 1/2" S.S. Body Bolt	4
V25060	Thrust Bushing	1
V25151B	Stem 2" FP, 3" FP & 4" Machined	1
V25153	Valve Handle for 2 3 & 4" FP	1
V25254	Valve Body 2" FP New Style	1

REPLACEMENT PARTS VFMT204FP - VSF200FPAF - V204FP - VSMT200FPAF		
PART NO.	DESCRIPTION	QTY.
V25020	3/8" x 1/2" Handle Bolt	1
V25121	Handle Washer 2" FP 3"	1
V25160	Upper Stem Bushing 2 & 3 FP, 4"	1
V25163	Stem O Ring FKM (viton type) 2 & 3 FP, 4"	1
V25255A	New Style Ball 2" FP	1
V25258A	2" FP Valve Ball Seat	2
V25264	Valve Body O Ring FKM (viton type)	2



REPLACEMENT PARTS -VSF200FPAF		
PART NO.	DESCRIPTION	QTY.
VF25256	2" FP "F" End Plate	1
VS25151B	New Style Short Stem	1
V20010	3/8" 16 x 2" Bolt Zinc Plated	6
V20018	3/8" S.S. Lock Washer	6
V20019	3/8" S.S. Body Nut	6
V25153SH	Regular Handle Straight	1
V25245	2" FP ANSI Flange Body	1

REPLACEMENT PARTS -VSMT200FPAF		
PART NO.	DESCRIPTION	QTY.
VMT25256	2" FP End Plate w/Male Pipe Thread	1
VS25151B	New Style Short Stem	1
V20010	3/8" 16 x 2" Bolt Zinc Plated	6
V20018	3/8" S.S. Lock Washer	6
V20019	3/8" S.S. Body Nut	6
V25153SH	Regular Handle Straight	1
V25245	2" FP ANSI Flange Body	1

The Spray Tech part number can be derived by adding the prefix 'TE' to the listed Banjo part numbers.



2" Standard Port Ball Valves

PATENTED

"Stubby Valve"TM

FEATURES

- Stainless steel bolts.
- Glass filled polypropylene.
- Multiple design options.
- Unique patented compact design.
- Lightweight.
- Maximum operating pressure
100 P.S.I. @ 70°F & 75 P.S.I. @ 150°F.
- All PTFE Seals.



PART NO.	DESCRIPTION	MAX PSI	PIPE SIZE	OPENING THRU BALL	QUANTITY
VSF200	2" Male Adapter X 2" Female NPT	100	2"	1½"	24/per box
VSMT200	2" Male NPT X 2" Female NPT	100	2"	1½"	24/per box
VSFMT200	2" Male Adapter X 2" Male NPT	100	2"	1½"	24/per box
VSFHB200	2" Male Adapter X 2" Hose Barb	100	2"	1½"	24/per box

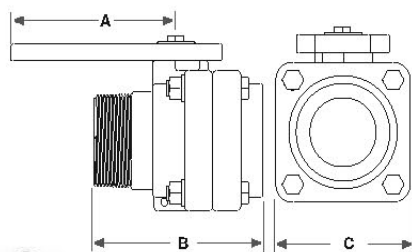

DIMENSION CHART IN INCHES (REFER TO DRAWING ON LEFT)

PART NO.	DESCRIPTION	A	B	C
VSF200	2" Male Adapter X 2" Female NPT	4.38	4.72	3.56
VSMT200	2" Male NPT X 2" Female NPT	4.38	4.50	3.56
VSFMT200	2" Male Adapter X 2" Male NPT	4.38	5.88	3.56
VSFHB200	2" Male Adapter X 2" Hose Barb	4.38	6.90	3.56



The Spray Tech part number can be derived by adding the prefix 'TE' to the listed Banjo part numbers.

BANJO VALVES

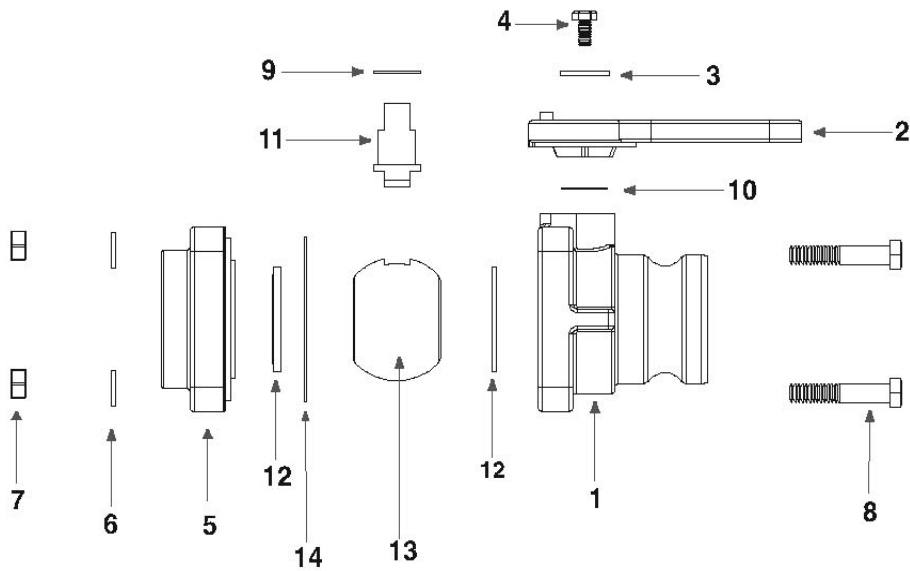

***Valve Repair Kits Contain Items Marked With Asterisk:**

- 1 Ball
- 2 Ball Seats
- 1 Body Gasket
- 1 Thrust Washer

NOTE: End Plates and body style may vary from picture.

REPLACEMENT PARTS VSF200 - VSMT200 - VSFMT200 - VSFHB200			
ITEM	PART NO.	DESCRIPTION	QTY.
2	VS20152SH	2" Short Style Handle	1
3	V20021	Handle Washer	1
4	V20020	Handle Bolt	1
6	V20018	Lock Washer	4
7	V20019	Body Nut	4
8	V20010SS	Body Bolt	4
9	V20060	Upper Stem Bushing	1
10	V20060*	Thrust Bearing	1
11	VS20151	Stem	1
12	VS20258A*	Seat	2
13	VS20255*	Ball	1
14	V21204*	Body Gasket	1
N/S	VS20200*	Repair Kit	1



REPLACEMENT PARTS VSF200 - VSFMT200			
ITEM	PART NO.	DESCRIPTION	QTY.
1	VF22254	2" "F" Style Body	1
5	VSMT20256	2" Male NPT End Plate	1



REPLACEMENT PARTS - VSFHB200			
ITEM	PART NO.	DESCRIPTION	QTY.
1	VF22254	2" "F" Style Body	1
5	VSHB20256	2" Hose Barb End Plate	1



REPLACEMENT PARTS -VSMT200			
ITEM	PART NO.	DESCRIPTION	QTY.
1	VMT22254	2" Male NPT Style Body	1
5	VS20256	2" Female End Plate	1

The Spray Tech part number can be derived by adding the prefix 'TE' to the listed Banjo part numbers.



2" Full Port Ball Valves

PATENTED

"Stubby Valve"TM

FEATURES

- Stainless steel bolts.
- 100% PTFE ball seats.
- Glass-filled polypropylene.
- FKM (viton type) Body Seals.
- Unique compact design.
- 100 P.S.I. @ 70°F and 75 P.S.I. @ 150°F.
- Lightweight.

VSMT204FP



VSF204FP



VS204FP



VSFMT204FP



PART NO.	DESCRIPTION	MAX PSI	PIPE SIZE	OPENING THRU BALL	QUANTITY
VSMT204FP	2" Male NPT X 2" Female NPT	100	2"	2"	18/per box
VSF204FP	2" Male Adapter X 2" Female NPT	100	2"	2"	18/per box
VS204FP	2" Female NPT X 2" Female NPT	100	2"	2"	18/per box
VSFMT204FP	2" Male Adapter X 2" Male NPT	100	2"	2"	18/per box

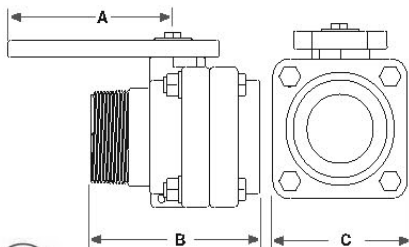

DIMENSION CHART IN INCHES (REFER TO DRAWING ON LEFT)

PART NO.	DESCRIPTION	A	B	C
VSMT204FP	2" Male NPT X 2" Female NPT	6.38	5.72	4.25
VSF204FP	2" Male Adapter X 2" Female NPT	6.38	5.91	4.25
VS204FP	2" Female NPT X 2" Female NPT	6.38	5.19	4.25
VSFMT204FP	2" Male Adapter X 2" Male NPT	6.38	6.50	4.25



The Spray Tech part number can be derived by adding the prefix 'TE' to the listed Banjo part numbers.

BANJO VALVES

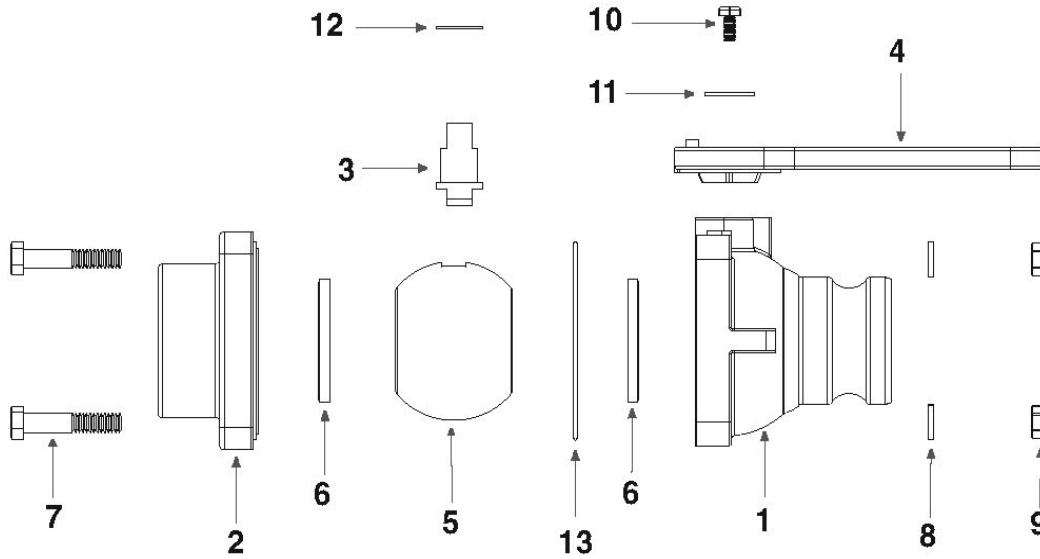

REPLACEMENT PARTS VSMT204FP - VS204FP - VSF204FP -VSFMT204FP			
ITEM	PART NO.	DESCRIPTION	QTY.
2	VSMT25356	2" FP Stubby MPT 4 Bolt EP	1
3	VS20151	Stem	1
4	VS25153	2" FP Stubby Handle	1
5	VS25255	2" FP Stubby Ball Machined	1
6	VS25258AR1	2" FP Stubby Valve Seat	2
7	V20010SS	3/8" 16 x 2" S.S. Bolt	4
8	V20018	3/8" S.S. Lock Washer	4
9	V20019	3/8" S.S. Body Nut	4
10	V20020	Retaining Bolt	1
11	V20021	Flat Handle Washer	1
12	V20060	PFTE Bearing Gasket	2
13	V25214V	FKM (viton type) Valve Body Seal	1

NOTE: End Plates and body style may vary from picture.



REPLACEMENT PARTS -VSMT204FP			
ITEM	PART NO.	DESCRIPTION	QTY.
1	VFT25254	2" FP Stubby Female NPT Body	1
2	VSMT25356	2" FP Stubby 4 Bolt MPT End Plate	1



REPLACEMENT PARTS -VSF204FP			
ITEM	PART NO.	DESCRIPTION	QTY.
1	VF25254	2" FP Stubby Male Quick Connect Body	1
2	VS25356	2" FP Stubby Female NPT Endplate	1



REPLACEMENT PARTS -VS204FP			
ITEM	PART NO.	DESCRIPTION	QTY.
1	VF25254	2" FP Stubby Male Quick Connect Body	1
2	VSMT25356	2" FP Stubby 4 Bolt MPT End Plate	1



REPLACEMENT PARTS -VSFMT204FP			
ITEM	PART NO.	DESCRIPTION	QTY.
1	VFT25254	2" FP Stubby Female NPT Body	1
2	VS25356	2" FP Stubby 4 Bolt NPT End Plate	1

The Spray Tech part number can be derived by adding the prefix 'TE' to the listed Banjo part numbers.



3" Standard Port Ball Valves

PATENTED

"3" Stubby Valve™

FEATURES

- Stainless steel bolts.
- Glass filled polypropylene.
- FKM (viton type) body seals.
- Five design options.
- Unique patented compact design.
- 100 P.S.I. @ 70°F and 75 P.S.I. @ 150°F.
- Lightweight.
- All PTFE Seals.

MVSF300



MVSMT300



VSMT300



VSF300



VSFMT300



PART NO.	DESCRIPTION	MAX PSI	PIPE SIZE	OPENING THRU BALL	QUANTITY
MVSF300	3" Manifold Flange X 3" Male Adapter	100	3"	2½"	6/per box
MVSMT300	3" Manifold Flange X 3" Male NPT	100	3"	2½"	8/per box
VSMT300	3" Female NPT X 3" Male NPT	100	3"	2½"	6/per box
VSF300	3" Female NPT X 3" Male Adapter	100	3"	2½"	6/per box
VSFMT300	3" Male NPT X 3" Male Adapter	100	3"	2½"	6/per box

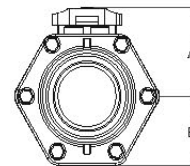

DIMENSION CHART IN INCHES (REFER TO DRAWING ON RIGHT)

PART NO.	DESCRIPTION	A	B	C*	D	E
MVSF300	3" Manifold Flange X 3" Male Adapter	3.63	2.84	5.25/9.25	4.60	5.02
MVSMT300	3" Manifold Flange X 3" Male NPT	3.63	2.84	5.25/9.25	4.60	4.45
VSMT300	3" Female NPT X 3" Male NPT	3.63	2.84	5.25/9.25	4.60	5.09
VSF300	3" Female NPT X 3" Male Adapter	3.63	2.84	5.25/9.25	4.60	5.65
VSFMT300	3" Male NPT X 3" Male Adapter	3.63	2.84	5.25/9.25	4.60	7.84

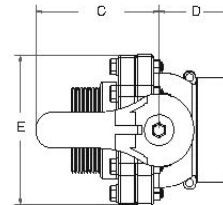

*Short handles: Add SH to end of part number. Dimension C = 5.25".



The Spray Tech part number can be derived by adding the prefix 'TE' to the listed Banjo part numbers.

NOTE: End Plates and body style may vary from picture.

REPLACEMENT PARTS - MVSF300 - MVSMT300- VSMT300 - VSF300 - VSFMT300			
ITEM	PART NO.	DESCRIPTION	QTY.
3	VS25151B	New Style Short Stem	1
4	VS30258*	3" Stubby Valve Seat	2
5	V20010SS	$\frac{3}{8}$ " 16 x 2" S.S. Bolt	6
6	V20018	$\frac{3}{8}$ " S.S. Lock Washer	6
7	V20019	$\frac{3}{8}$ " S.S. Body Nut	6
8	V25020	$\frac{3}{8}$ " x $\frac{1}{2}$ " Handle Bolt	1
9	V25121	Handle Washer 2" FP 3"	1
10	V25153	Regular Handle Straight	1
11	V25160*	Upper Stem Bushing 2 & 3 FP, 4	1
12	V25163*	Stem O Ring FKM (viton type) 2 & 3 FP, 4	1
13	VS30255*	Valve Ball 3" New Style	1
14	V30265*	Valve Body O Ring FKM (viton type) 3"	1

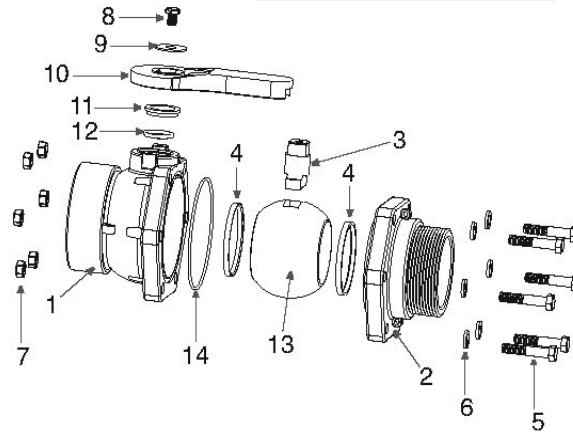

REPLACEMENT PARTS - MVSF300			
ITEM	PART NO.	DESCRIPTION	QTY.
1	MVS30254	3" Stubby Body w/Manifold Flange	1
2	VSF30264	3" Stubby Valve "F" Endplate	1



REPLACEMENT PARTS - VSF300			
ITEM	PART NO.	DESCRIPTION	QTY.
1	VS30254	3" Stubby Body	1
2	VSF30264	3" Stubby Valve "F" Endplate	1



REPLACEMENT PARTS - MVSMT300			
ITEM	PART NO.	DESCRIPTION	QTY.
1	MVS30254	3" Stubby Body w/Manifold Flange	1
2	VSMT30264	3" Stubby Valve Male NPT Endplate	1



REPLACEMENT PARTS - VSFMT300			
ITEM	PART NO.	DESCRIPTION	QTY.
1	VSMT30254	3" MT Stubby Body	1
2	VSF30264	3" Stubby Valve "F" Endplate	1



REPLACEMENT PARTS - VSMT300			
ITEM	PART NO.	DESCRIPTION	QTY.
1	VS30254	3" Stubby Body	1
2	VSMT30264	3" Stubby Valve Male NPT Endplate	1

***Valve Repair Kits Contain Items Marked With Asterisk :**
 1 Ball 2 Body O-Rings
 2 Ball Seats 1 Upper Stem Bushing 1 Stem O-Ring

The Spray Tech part number can be derived by adding the prefix 'TE' to the listed Banjo part numbers.

BANJO®

3-Way Poly Ball Valves

FEATURES

- Stainless Steel Bolts.
- Precision molded in polypropylene. Polypropylene is reinforced with fiberglass for additional strength.
- Self-aligning ball moves freely against the PTFE seats for smooth operation.
- Ball is diamond turned, after molding, to make it spherically perfect, which provides precise contact between ball and seats.
- FKM (viton type) seats.
- PTFE self-lubricating stem bushings and seats.
- Maximum operating pressure 100 P.S.I.



See handle chart below.

PART NO.	DESCRIPTION	MAX PSI	PIPE SIZE	OPENING THRU BALL	QUANTITY PER BOX	HANDLE TYPE
V075BL	3/4" 3 Way Bottom Load Poly Valve	100	3/4"	1"	18/Per Box	T
V100BL	1" 3 Way Bottom Load Poly Valve	100	1"	1"	18/Per Box	T
V125BL	1 1/4" 3 Way Bottom Load Poly Valve	100	1 1/4"	1 1/2"	12/Per Box	T
V150BL	1 1/2" 3 Way Bottom Load Poly Valve	100	1 1/2"	1 1/2"	12/Per Box	T
V200BL	2" 3 Way Bottom Load Poly Valve	100	2"	2"	8/Per Box	Straight

BOTTOM LOAD

Directional flow, right or left. Valve can be turned off to stop flow.



See handle chart below.

PART NO.	DESCRIPTION	MAX PSI	PIPE SIZE	OPENING THRU BALL	QUANTITY PER BOX	HANDLE TYPE
V075SL	3/4" 3 Way Side Load Poly Valve	100	3/4"	1"	18/Per Box	Straight
V100SL	1" 3 Way Side Load Poly Valve	100	1"	1"	18/Per Box	Straight
V125SL	1 1/4" 3 Way Side Load Poly Valve	100	1 1/4"	1 1/2"	12/Per Box	T
V150SL	1 1/2" 3 Way Side Load Poly Valve	100	1 1/2"	1 1/2"	12/Per Box	T
V200SL	2" 3 Way Side Load Poly Valve	100	2"	2"	8/Per Box	Straight

SIDE LOAD

Directional flow, right or left. Valve cannot be turned off.

THREADED SIDE & BOTTOM LOAD WITH OPTIONAL HANDLE

PART NO.	STANDARD HANDLE	OPTIONAL VALVE PART NO.	OPTIONAL HANDLE PART NO.
V075SL	V10153A (straight)	VT075SL Non Stock Item	V10353S (t handle)
V100SL	V10153A (straight)	VT100SL Non Stock Item	V10353TS (t handle)
V125SL	V20353TS (t handle)	VT125SL Non Stock Item	V20153 (straight)
V150SL	V20353TS (t handle)	VT150SL Non Stock Item	V20153 (straight)
V200SL	V25153SH (straight)	VT200SL Non Stock Item	V25353TS (t handle)
V200BL	V25353B (straight)	VT200BL Non Stock Item	V25353TB (t handle)



The Spray Tech part number can be derived by adding the prefix 'TE' to the listed Banjo part numbers.

BANJO VALVES

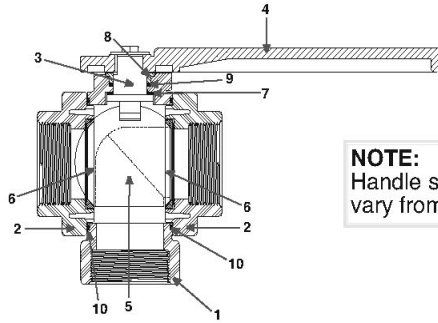

NOTE:
Handle style will vary from picture.

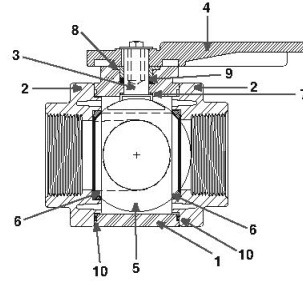

Bottom Load 3-Way Poly Ball Valves

REPLACEMENT PARTS – V075BL – V100BL				
ITEM	PART NO.	DESCRIPTION	QTY.	
1	V07354B	3/4" Valve Body	1	
1	V10354B	1" Valve Body	1	
2	V07357	3/4" End Plate	2	
2	V10257	1" End Plate	2	
3	V10151A	Stem	1	
4	V10353TB	Handle - T	1	
5	V10355B	Ball	1	
6	V10258	Ball Seats	2	
7	V10060	Thrust Bushing	1	
8	V10159	Upper Stem Bushing	1	
9	V10163	Stem O-Ring – FKM (viton type)	1	
10	V10264	Valve Body O-Ring-FKM (viton type)	2	

Side Load 3-Way Poly Ball Valves

REPLACEMENT PARTS –V075SL – V100SL				
ITEM	PART NO.	DESCRIPTION	QTY.	
1	V07354S	3/4" Valve Body	1	
1	V10354S	1" Valve Body	1	
2	V07357	3/4" End Plate	2	
2	V10257	1" End Plate	2	
3	V10151A	Stem	1	
4	V10153A	Handle - Straight	1	
5	V10355S	Ball	1	
6	V10258	Ball Seats	2	
7	V10060	Thrust Bushing	1	
8	V10159	Upper Stem Bushing	1	
9	V10163	Stem O-Ring – FKM (viton type)	1	
10	V10264	Valve Body O-Ring-FKM (viton type)	2	

REPLACEMENT PARTS – V125BL – V150BL				
ITEM	PART NO.	DESCRIPTION	QTY.	
1	V20344B	1 1/4" Valve Body	1	
1	V20354B	1 1/2" Valve Body	1	
2	V20267	1 1/4" End Plate	2	
2	V20257	1 1/2" End Plate	2	
3	V20151M	Stem	1	
4	V20353TB	Handle - T	1	
5	V20355B	Ball	1	
6	V20258	Ball Seats	2	
7	V20060	Thrust Bushing	1	
8	V20159	Upper Stem Bushing	1	
9	V20163	Stem O-Ring – FKM (viton type)	1	
10	V20264	Valve Body O-Ring-FKM (viton type)	2	

REPLACEMENT PARTS – V125SL – V150SL				
ITEM	PART NO.	DESCRIPTION	QTY.	
1	V20344S	1 1/4" Valve Body	1	
1	V20354S	1 1/2" Valve Body	1	
2	V20267	1 1/4" End Plate	2	
2	V20257	1 1/2" End Plate	2	
3	V20151M	Stem	1	
4	V20353TS	Handle - T	1	
5	V20355S	Ball	1	
6	V20258	Ball Seats	2	
7	V20060	Thrust Bushing	1	
8	V20159	Upper Stem Bushing	1	
9	V20163	Stem O-Ring – FKM (viton type)	1	
10	V20264	Valve Body O-Ring-FKM (viton type)	2	

REPLACEMENT PARTS – V200BL				
ITEM	PART NO.	DESCRIPTION	QTY.	
1	V25354B	2" Valve Body	1	
2	V25356	2" End Plate	2	
3	V25151B	Stem	1	
4	V25353B	Handle - Straight	1	
5	V25355B	Ball	1	
6	V25258	Ball Seats	2	
7	V25060	Thrust Bushing	1	
8	V25160	Upper Stem Bushing	1	
9	V25163	Stem O-Ring – FKM (viton type)	1	
10	V25264	Valve Body O-Ring-FKM (viton type)	2	

REPLACEMENT PARTS – V200SL				
ITEM	PART NO.	DESCRIPTION	QTY.	
1	V25354S	Valve Body	1	
2	V25356	End Plate	2	
3	V25151B	Stem	1	
4	V25153SH	Handle – Straight	1	
5	V25355S	Ball	1	
6	V25258	Ball Seats	2	
7	V25060	Thrust Bushing	1	
8	V25160	Upper Stem Bushing	1	
9	V25163	Stem O-Ring – FKM (viton type)	1	
10	V25264	Valve Body O-Ring-FKM (viton type)	2	

The Spray Tech part number can be derived by adding the prefix 'TE' to the listed Banjo part numbers.



Polypropylene Nozzle Valves

FEATURES

- Lightweight hose end valve for convenient transfer of liquids into drums, tanks, etc.
- Angled end flange with 8" long polypropylene fill spout.
- All Stainless Bolts.



PART NO.	DESCRIPTION	FEMALE NPT	PIPE SIZE	OPENING THRU BALL	QUANTITY PER BOX	MAX PSI
VA150	1 1/2" Nozzle Valve with 90° Elbow	1 1/2"	1 1/2" x 8"	1 1/2"	12/Per Box	150
VA200/150	2" X 1 1/2" Nozzle Valve w/ 90° Elbow	2" X 1 1/2"	1 1/2" x 8"	1 1/2"	12/Per Box	150
VA200	2" Nozzle Valve with 90° Elbow	2"	2" X 8"	1 1/2"	12/Per Box	150
VA200FP	2" FP Nozzle Valve with 90° Elbow	2"	2" X 8"	2 1/16"	6/Per Box	150
V25165	2" Nozzle Pipe Only (VA200 & VA200FP)	N/A	8"	N/A	N/A	N/A
V20166	1 1/2" Nozzle Pipe Only (VA150 & VA200/150)	N/A	8"	N/A	N/A	N/A

FEATURES

- Lightweight hose end valve for convenient transfer of liquids into drums, tanks, etc.
- Angled end flange with 8" long polypropylene fill spout.
- All Stainless Bolts.



PART NO.	DESCRIPTION	FEMALE NPT	PIPE SIZE	OPENING THRU BALL	QUANTITY PER BOX	MAX PSI
VA100	1" Nozzle Valve with 45° Elbow	1"	1"	3/4"	24/per box	150
UVA100FP	1" FP EPDM Nozzle Valve w/45° Elbow	1"	1"	1"	1pc.	100
V10161	1" Poly Nozzle Pipe (VA100 & UVA100FP)	N/A	1"	N/A	N/A	N/A

Poly Dispensing Nozzle

FEATURES

- Glass filled polypropylene.
- Stainless steel handle, spring and pin.
- FKM (viton type) rubber parts only.
- Resists corrosion.
- Padlock capability.
- 75 P.S.I. Maximum.



PART NO.	DESCRIPTION	FEMALE NPT	PIPE SIZE	OPENING THRU BALL	QUANTITY
VN100	1" Poly Dispensing Nozzle	1"	1"	N/A	1 pc.



The Spray Tech part number can be derived by adding the prefix 'TE' to the listed Banjo part numbers.

BANJO VALVES



REPLACEMENT PARTS - VA200FP			
PART NO.	DESCRIPTION	QTY.	
V25151B	Stem	1	
V25152	Red Angle Handle	1	
V25254	Valve Body	1	
V25255A*	Valve Ball	1	
V25256	End Plate 2" FPT	2	
V25261	Angle End Flange 2" FP	1	
V25258A*	Ball Seat	2	
V25264*	Valve Body O Ring FKM (viton type)	2	
V25160*	Upper Stem Bushing	1	
V25060*	Thrust Washer	1	
V25163*	Stem O Ring FKM (viton type)	1	
V25017	3/8" x 4 1/2" S.S. Body Bolt	6	
V20018	3/8" S.S. Washer	6	
V20019	3/8" S.S. Nut	6	
V25020	3/8" x 1/2" S.S. Handle Bolt	1	
V25121	S.S. Handle Washer	1	
V25165	Nozzle Pipe 2" x 8"	1	
V25200	Valve Repair Kit	1	



REPLACEMENT PARTS - VA100			
PART NO.	DESCRIPTION	QTY.	
V07151A	Stem	1	
V10153A	Handle	1	
V07254	Valve Body	1	
V07155*	Valve Ball	1	
V07256	End Plate 1"	2	
V07258A*	Ball Seat	2	
V07264*	Valve Body O Ring FKM (viton type)	2	
V07159*	Upper Stem Bushing	1	
V07060*	Thrust Washer	1	
V07163*	Stem O Ring FKM (viton type)	1	
V07017	1/4" x 3" S.S. Body Bolt	4	
V07018	1/4" S.S. Lock Washer	4	
V07019	1/4" S.S. Nut	4	
V10020A	#10 X 1 1/4" S.S. Handle Bolt	1	
V07021A	S.S. Handle Washer	1	
V10161	1" Poly Nozzle Pipe	1	
V07200	Valve Repair Kit	1	



REPLACEMENT PARTS - VA150 – VA200-VA200/150			
PART NO.	DESCRIPTION	QTY.	
V20151M	Stem	1	
V20152	Red Angle Handle	1	
V20254	Valve Body	1	
V20255A*	Valve Ball	1	
V20256	2" End Plate	2	
V20257	1 1/2" End Plate	2	
V20258A*	Ball Seat	2	
V20264*	Valve Body O Ring FKM (viton type)	2	
V20159*	Upper Stem Bushing	1	
V20060*	Thrust Washer	1	
V20261	Angle End Flange 2"	1	
V20262	Angle End Flange 1 1/2"	1	
V20163*	Stem O Ring FKM (viton type)	1	
V20166	Nozzle Pipe 1 1/2" x 8"	1	
V25165	Nozzle Pipe 2" x 8"	1	
V20017	3/8" x 4" S.S. Body Bolt	4	
V20018	3/8" S.S. Lock Washer	4	
V20019	3/8" S.S. Nut	4	
V20020	1/4" x 1/2" S.S. Handle Bolt	1	
V20021	S.S. Handle Washer	1	
V20200	Valve Repair Kit	1	



REPLACEMENT PARTS - UVA100FP			
PART NO.	DESCRIPTION	QTY.	
UV10150	1" Union End Cap	1	
UV10151	1" Union Stem	1	
UV10153	1" Union Handle	1	
UV10163	1" Union Stem O Ring (EPDM)	2	
UV10254	1" Union Valve Body	1	
UV10255	1" Union Valve Ball	1	
UV10256	1" Union End Plate	1	
UV10258	1" Union Valve Seat	2	
UV10264	1" Union Body O Ring (EPDM)	1	
V10161	1" Poly Nozzle Pipe	1	



REPLACEMENT PARTS - VN100			
PART NO.	DESCRIPTION	QTY.	
VN10253	1" Valve Nozzle Handle	1	
VN10254	1" Valve Nozzle Body	1	
VN10263	1" Valve Nozzle Stem O Ring	2	
VN10264	1" Valve Nozzle Body O Ring	1	
VN10265	Snap Ring for Valve Nozzle	1	
VN10269	1" Valve Nozzle Plug	1	
VN10270	1" Valve Nozzle Poppet	1	
VN10271	1" Valve Nozzle Gasket	1	
VN10273	1" Valve Nozzle Pin	1	
VN10274	1" Valve Nozzle Spring	1	
VN10200	Repair Kit (includes Seals, O Rings, Poppet, Gasket, Spring, Snap Ring)	1	

***Valve Repair Kits Contain Items Marked With Asterisk :**

1 Ball 2 Body O Rings 1 Thrust Washer
2 Ball Seats 1 Upper Stem Bushing 1 Stem O Ring

The Spray Tech part number can be derived by adding the prefix 'TE' to the listed Banjo part numbers.



Single Union Polypropylene Ball Valve

FEATURES

- Precision molded in glass reinforced polypropylene, for strength and chemical resistance.
- PTFE seats for smooth operation and proper sealing characteristics.
- EPDM O-rings to handle most fertilizers and many chemicals. FKM(viton type) available.
- Double O-rings in stem area for extra sealing protection.
- Interlocking body and end plate to allow easy thread connection when installing valves.
- Maximum operating pressure 100 P.S.I. at 70°F.



PART NO.	DESCRIPTION	MAX PSI	PIPE SIZE	OPENING THRU BALL	QUANTITY
UV050FP	1/2" Single Union Poly Valve	100	1/2"	3/4"	150/Per Box
UV075FP	3/4" Single Union Poly Valve	100	3/4"	3/4"	150/Per Box
UV100FP	1" Single Union Poly Valve	100	1"	1"	100/Per Box
UV125FP	1 1/4" Single Union Poly Valve	100	1 1/4"	1 1/2"	24/Per Box
UV150FP	1 1/2" Single Union Poly Valve	100	1 1/2"	1 1/2"	24/Per Box
UV200FP	2" Single Union Poly Valve	100	2"	2"	18/Per Box

Spin Weld Polypropylene Ball Valve

FEATURES

- One piece construction.
- Precision molded in durable polypropylene, for strength and chemical resistance.
- PTFE seats for smooth operation and proper sealing characteristics.
- Quality with economy.
- Maximum operating pressure 150 P.S.I. at 70°F.



*** SPECIAL ORDER ITEM ***

NPT PART NO.	BSP PART NO.	DESCRIPTION	STEM O-RING	MAX PSI	PIPE SIZE	OPENING THRU BALL
WV050FP	WV050FPB	1/2" Poly Spinweld Valve	EPDM	150	1/2"	1/2"
WV075FP	WV075FPB	3/4" Poly Spinweld Valve	EPDM	150	3/4"	3/4"
WV100FP	WV100FPB	1" Poly Spinweld Valve	EPDM	150	1"	1"
WV125FP	WV125FPB	1 1/4" Poly Spinweld Valve	EPDM	150	1 1/4"	1 1/4"
WV150FP	WV150FPB	1 1/2" Poly Spinweld Valve	EPDM	150	1 1/2"	1 1/2"
WV200FP	WV200FPB	2" Poly Spinweld Valve	EPDM	150	2"	2"



NPT PART NO.	DESCRIPTION	STEM O-RING	MAX PSI	PIPE SIZE	OPENING THRU BALL
WSFMT200	2" Male Adapter x 2" Male NPT Standard Port	Viton	150	2"	1 1/2"
WSFMT200FP	2" Male Adapter x 2" Male NPT Full Port	Viton	150	2"	2"



The Spray Tech part number can be derived by adding the prefix 'TE' to the listed Banjo part numbers.

*** SPECIAL ORDER ITEM ***

Poly Air Actuated Shutoff Valves



PART NO.	DESCRIPTION	MAX PSI	PIPE SIZE	PRESSURE DIFFERENCE	QTY.
PV075	3/4" x 3/4" Poly Pinch Valve EPDM	70	3/4"	15 to 20 P.S.I.	1
PV075V	3/4" FKM (viton type) Poly Pinch Valve	70	3/4"	15 to 20 P.S.I.	1
PV100	1" x 1" Poly Pinch Valve EPDM	70	1"	15 to 20 P.S.I.	1
PV100V	1" x 1" FKM (viton type) Pinch Valve	70	1"	15 to 20 P.S.I.	1
PV100 075	1" x 3/4" Poly Pinch Valve EPDM	70	1" X 3/4"	15 to 20 P.S.I.	1
PV100 075V	1" x 3/4" FKM (viton type) Pinch Valve	70	1" X 3/4"	15 to 20 P.S.I.	1
PV100 075B	1" x 3/4" Poly Pinch Valve Female Coupler EPDM	70	1" X 3/4"	15 to 20 P.S.I.	1
PV100 075BV	1" FPT x 3/4" Female Coupler FKM (viton type) Poly Pinch Valve	70	1" X 3/4"	15 to 20 P.S.I.	1

Attention: The polypropylene air actuated valve is normally an open valve, and has a maximum liquid pressure of 70 P.S.I.

The pressure differential (pressure it takes to close valve) of the valve is 15 to 20 P.S.I.

REPLACEMENT PARTS – PV075 - PV100 - PV100-075 - PV100-075B - PV075V PV100V - PV100-075V - PV100-075BV			
ITEM	PART NO.	DESCRIPTION	QTY.
2	PV10254	Poly Pinch Valve Body	1
4	12723	1/4" Drain Plug	1
5	12724	O Ring for Drain Plug EPDM	1

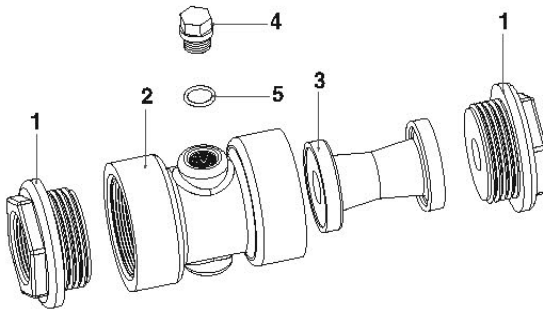

REPLACEMENT PARTS – PV075			
ITEM	PART NO.	DESCRIPTION	QTY.
1	PV07257	3/4" End Plate for Pinch Valve	2
3	PV10265	EPDM Rubber Bladder Seal	1

REPLACEMENT PARTS – PV075V			
ITEM	PART NO.	DESCRIPTION	QTY.
1	PV07257	3/4" End Plate for Pinch Valve	2
3	PV10265V	FKM (viton type) Rubber Bladder Seal	1

REPLACEMENT PARTS – PV100 - PV100-075			
ITEM	PART NO.	DESCRIPTION	QTY.
1	PV07256	1" End Plate for Pinch Valve	2
1	PV07257	3/4" End Plate for Pinch Valve	1 (only)
3	PV10265	EPDM Rubber Bladder Seal	1

REPLACEMENT PARTS – PV100V - PV100-075V			
ITEM	PART NO.	DESCRIPTION	QTY.
1	PV07256	1" End Plate for Pinch Valve	2
1	PV07257	3/4" End Plate for Pinch Valve	1 (only)
3	PV10265V	FKM (viton type) Rubber Bladder Seal	1

REPLACEMENT PARTS – PV100-075B			
ITEM	PART NO.	DESCRIPTION	QTY.
1	PV07256	1" End Plate for Pinch Valve	1
1	PV07257B	3/4" Pinch Valve Female Coupler End	1
3	PV10265	EPDM Rubber Bladder Seal	1

REPLACEMENT PARTS – PV100-075BV			
ITEM	PART NO.	DESCRIPTION	QTY.
1	PV07256	1" End Plate for Pinch Valve	1
1	PV07257B	3/4" Pinch Valve Female Coupler End	1
3	PV10265V	FKM (viton type) Rubber Bladder Seal	1

The Spray Tech part number can be derived by adding the prefix 'TE' to the listed Banjo part numbers.



Polypropylene Check Valve

FEATURES

- One Piece Construction.
- Flanged Connections.
- 150 P.S.I. Maximum.
- 1-2 P.S.I. Spring.
- Glass Reinforced Polypropylene.
- 316 Stainless Steel Springs.
- EPDM Gasket (FKM Optional).



POLYPROPYLENE CHECK VALVE

PART NO.	DESCRIPTION	MAX PSI	FLOW	QUANTITY
MCV100	1" Flanged Poly Check Valve	150	1"	1
MCV200	2" Flanged Poly Check Valve	150	1 1/2"	1
MCV220	2" Full Port Poly Check Valve	150	2"	1

316 Stainless Steel Two Piece Ball Valves

FEATURES

- 316 stainless steel.
- Blow out proof stem.
- All valves 100% tested by air, underwater at 100 P.S.I. in open and closed positions.
- Latch locking handle performs in both open and closed positions.
- Mounting pad.
- PTFE seals and seats.
- All full port design.
- Valves rated at 1,000 P.S.I.



REPLACEMENT HANDLES

PART NO.	VALVE SIZE
VSS05153	1/4" x 3/8" & 1/2"
VSS07153	3/4"
VSS10153	1" & 1 1/4"
VSS15153	1 1/2"
VSS20153	2"
VSS35153	3"

PART NO.	DESCRIPTION	MAX PSI	PIPE SIZE	OPENING THRU BALL	QUANTITY PER BOX	HANDLE TYPE
VSS025	1/4" x 1/4" 316 SS Full Port Ball Valve	1000	1/4"	1/4"	1	Straight
VSS038	3/8" x 3/8" 316 SS Full Port Ball Valve	1000	3/8"	3/8"	1	Straight
VSS050	1/2" x 1/2" 316 SS Full Port Ball Valve	1000	1/2"	1/2"	1	Straight
VSS075	3/4" x 3/4" 316 SS Full Port Ball Valve	1000	3/4"	3/4"	1	Straight
VSS100	1" x 1" 316 SS Full Port Ball Valve	1000	1"	1"	1	Straight
VSS125	1 1/4" x 1 1/4" 316 SS Full Port Ball Valve	1000	1 1/4"	1 1/4"	1	Straight
VSS150	1 1/2" x 1 1/2" 316 SS Full Port Ball Valve	1000	1 1/2"	1 1/2"	1	Straight
VSS200	2" x 2" 316 SS Full Port Ball Valve	1000	2"	2"	1	Straight
VSS300	3" x 3" 316 SS Full Port Ball Valve	1000	3"	3"	1	Straight



The Spray Tech part number can be derived by adding the prefix 'TE' to the listed Banjo part numbers.



Electric Ball Valves

Stainless Steel Ball & Stem

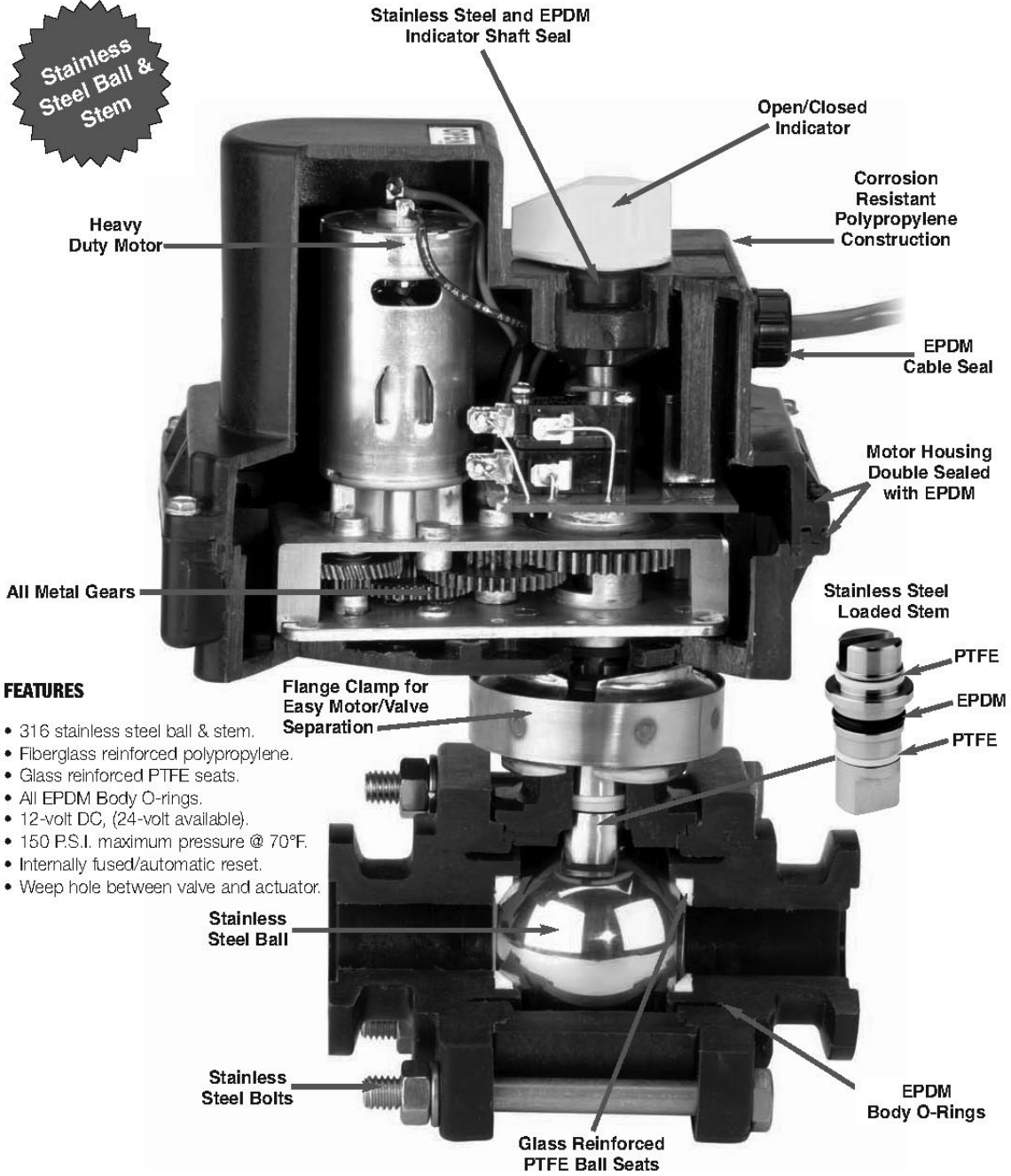

FEATURES

- 316 stainless steel ball & stem.
- Fiberglass reinforced polypropylene.
- Glass reinforced PTFE seats.
- All EPDM Body O-rings.
- 12-volt DC, (24-volt available).
- 150 P.S.I. maximum pressure @ 70°F.
- Internally fused/automatic reset.
- Weep hole between valve and actuator.

BANJO

Electric Valves

3/4", 1", 1 1/4" Threaded

FEATURES

- 316 stainless steel ball & stem.
- Stainless steel hardware.
- Fiberglass reinforced polypropylene.
- Glass reinforced PTFE seats.
- FKM (viton type) or EPDM O-rings.
- 12-volt DC operated.
- 150 P.S.I. maximum pressure @ 70°F.
- Easily repairable.
- Open/closed indicator.



ON/OFF Electric Valves - 3/4 Second Response Time

PART NO.	DESCRIPTION	MAX. PSI	PIPE SIZE	OPENING THRU BALL	QUANTITY
EVO75	3/4" Electric Valve	150	3/4"	1"	1
EV100FP	1" Electric Valve	150	1"	1"	1
EV125	1 1/4" Electric Valve	150	1 1/4"	1"	1

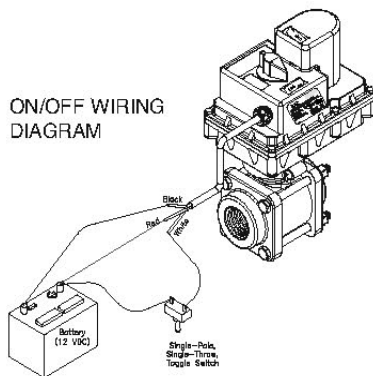

REGULATING WIRING DIAGRAM

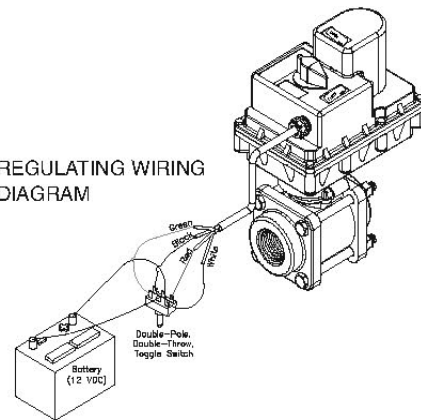

REGULATING Electric Valves - 4 Second Response Time

PART NO.	DESCRIPTION	MAX. PSI	PIPE SIZE	OPENING THRU BALL	QUANTITY
EVR075	3/4" Electric Valve	150	3/4"	1"	1
EVR100FP	1" Electric Valve	150	1"	1"	1
EVR125	1 1/4" Electric Valve	150	1 1/4"	1"	1



The Spray Tech part number can be derived by adding the prefix 'TE' to the listed Banjo part numbers.

BANJO®

ELECTRIC VALVES

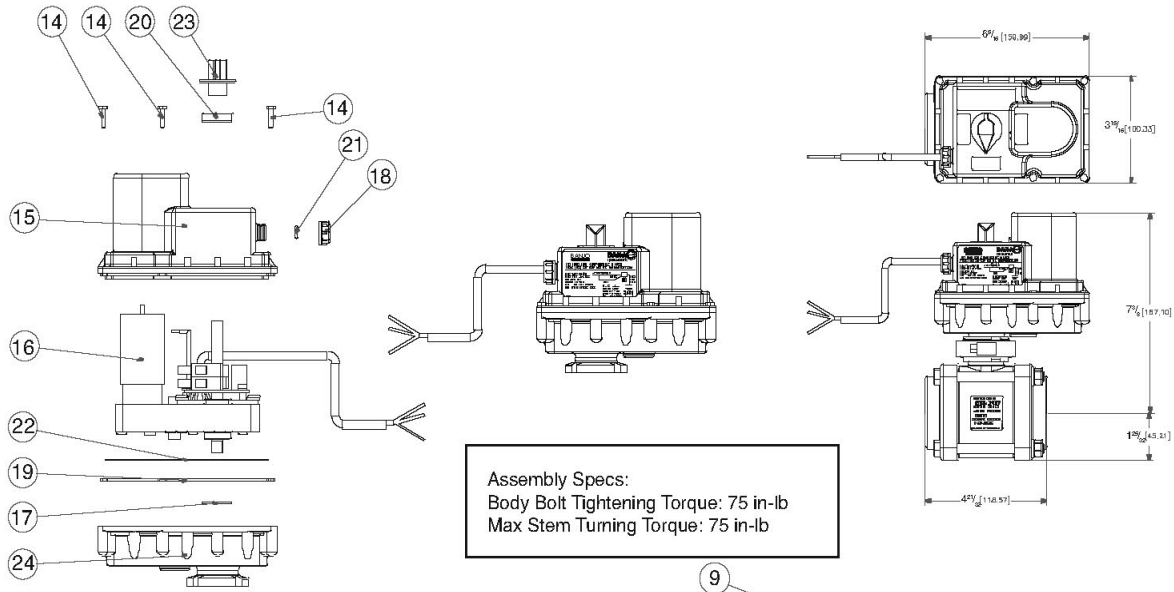

Fast repair replacement options.

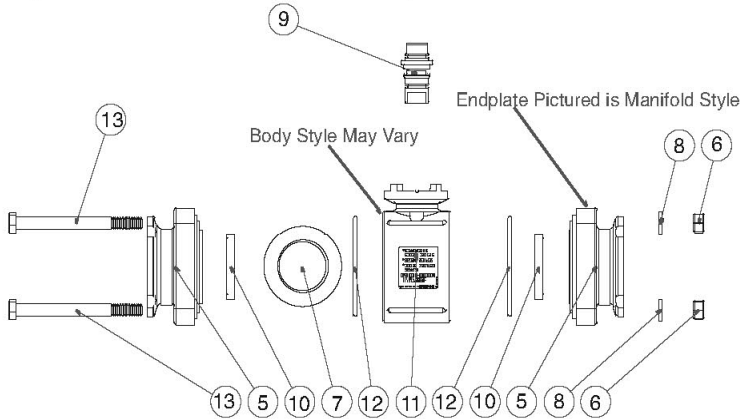
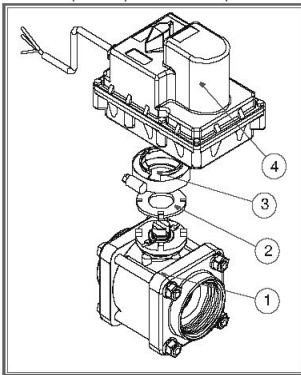

REPLACEMENT PARTS			
EV075 - EVR075 - EV100FP - EVR100FP			
EV125 - EVR125			
ITEM	PART NO.	DESCRIPTION	QTY.
1	EV075XR1	3/4" Electric Valve Sub Assembly	1
1	EV100XR1	1" FP Electric Valve Sub Assembly	1
1	EV125XR1	1 1/4" Electric Valve Sub Assembly	1
2	MVE004	Electric Valve Flange Gasket	1
3	FC100	1" Flange clamp	1
4	EV3100	3/4" Second 3 Wire motor Assembly	1
4	EVR3100	Regulating 4 Wire, 4 Second	1
4	EVR3102	Regulating 2 Wire, 8 Second	1
5	VE07357	3/4" Threaded Endplate for EV	2
5	VE10257A	1" FP Threaded Endplate for EV	2
5	VE10256A	1 1/4" Threaded Endplate for EV	2
6	V10119	5/16" Stainless Steel Body Nut	4
7	VE10155SSH	1" EV 316 Stainless Steel Hollow Ball	1
8	V10118	5/16" Stainless Steel Lock Washer	4
9	MEV10151	1" Stainless Steel Stem w/Seals	1
10	VE10258A	1" Electric Ball Seat	2
11	MEV10254A	EV Body 1"	1

REPLACEMENT PARTS			
EV075 - EVR075 - EV100FP - EVR100FP			
EV125 - EVR125			
ITEM	PART NO.	DESCRIPTION	QTY.
12	VE10264	1" EV Body FKM O-Ring	2
13	V10117	5/16" X 3 1/2" SS Body Bolt	4
14	VE15220	Housing Screw	8
15	MVE10102	EV Housing Top for Small Motor	1
16	VE4984	1 1/4" Hi Torque On/Off Motor	1
16	VE4983	4 Second 4 Wire HT On/Off Motor	1
16	VE4985	8 Second 2 Wire HT Reg Motor	1
17	MVE105	EV Motor Shaft Gasket	1
18	MVE002	Hayco 1/4" Threaded Bushing	1
19	MVE104	Outer EV Housing Gasket	1
20	VE109E	Indicator Seal	1
21	MVE007	3mm X 5mm FKM O-Ring	1
22	MVE106	Inner EV Housing Gasket	1
23	VE107A	EV Flow Indicator	1
24	MEV10101	EV Housing Bottom for Small Motor	1
25	EV10210	Repair Kit (Includes Parts 2, 9, 10, 12)	1

The Spray Tech part number can be derived by adding the prefix 'TE' to the listed Banjo part numbers.

BANJO®

Electric Valves

1 1/2", 2" Threaded

FEATURES

- 316 stainless steel ball & stem.
- Stainless steel hardware.
- Fiberglass reinforced polypropylene.
- Glass reinforced PTFE seats.
- FKM (viton type) or EPDM O-rings.
- 12-volt DC operated.
- 150 P.S.I. maximum pressure @ 70°F.
- Easily repairable.
- Open/closed indicator.



ON/OFF Electric Valves - 1 1/4 Second Response Time

PART NO.	DESCRIPTION	MAX. PSI	PIPE SIZE	OPENING THRU BALL	QUANTITY
EV150	1 1/2" Electric Valve	150	1 1/2"	1 1/2"	1
EV200	2" Electric Valve	150	2"	1 1/2"	1

REGULATING WIRING DIAGRAM

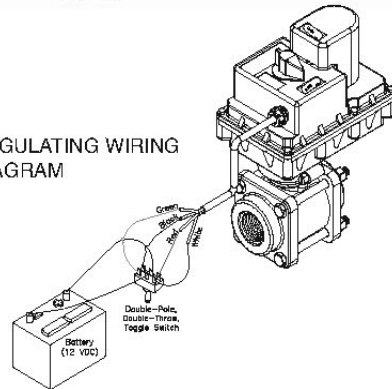

ON/OFF WIRING DIAGRAM

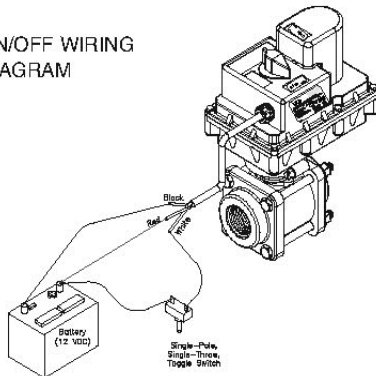

REGULATING Electric Valves - 4 Second Response Time

PART NO.	DESCRIPTION	MAX. PSI	PIPE SIZE	OPENING THRU BALL	QUANTITY
EVR150	1 1/2" Electric Valve	150	1 1/2"	1 1/2"	1
EVR200	2" Electric Valve	150	2"	1 1/2"	1



The Spray Tech part number can be derived by adding the prefix 'TE' to the listed Banjo part numbers.



ELECTRIC VALVES

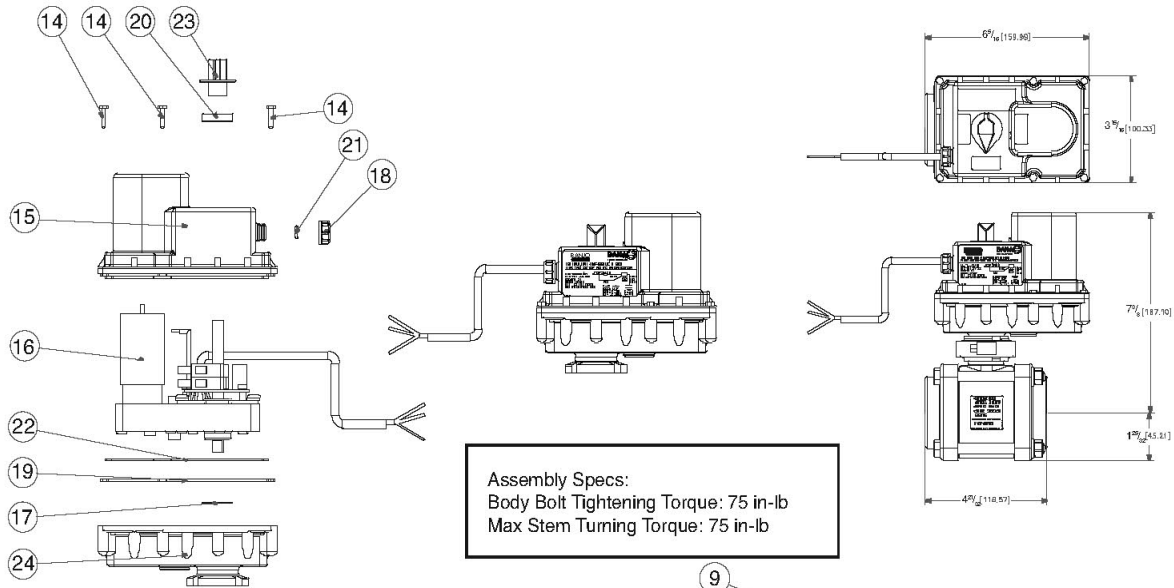

Fast repair replacement options.

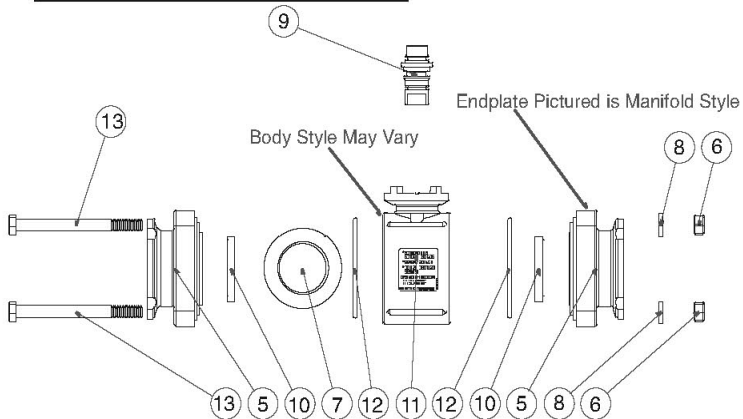
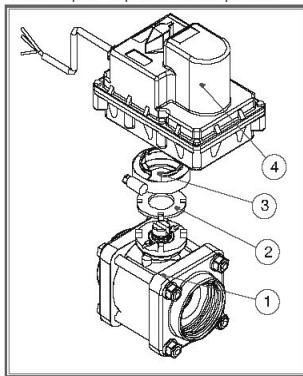

REPLACEMENT PARTS EV150 - EV200 - EVR150M - EVR200			
ITEM	PART NO.	DESCRIPTION	QTY.
1	EV150XR1	1 1/2" FP Electric Valve Sub Assembly	1
1	EV200XR1	2" Electric Valve Sub Assembly	1
2	MVE004	Electric Valve Flange Gasket	1
3	FC100	1" Flange clamp	1
4	EV4100	1 1/4 Second 3 Wire Motor Assembly	1
4	EVR4100	Regulating 4 Wire, 4 Second	1
4	EVR4102	Regulating 2 Wire, 6 Second	1
5	VE20257	1 1/2" Threaded Endplate for EV	2
5	VE20256	2" Threaded Endplate for EV	2
6	V20019	3/8" Stainless Steel Body Nut	4
7	VE20255SSH	2" EV 316 Stainless Steel Hollow Ball	1
8	V20018	3/8" Stainless Steel Lock Washer	4
9	MEV10151	1" Stainless Steel Stem w/Seals	1
10	VE20258	1 1/2" & 2" Electric Ball Seat	2
11	MEV20254A	EV Body 1 1/2" & 2"	1
12	VE20264	2" EV Body FKM O-Ring	2
13	V20017	3/8" X 4" Stainless Steel Body Bolt	4

REPLACEMENT PARTS EV150 - EV200 - EVR150 - EVR200			
ITEM	PART NO.	DESCRIPTION	QTY.
14	VE15220	Housing Screw	6
15	MVE25102	EV Housing Top for Large Motor	1
16	VE4987	1 1/4" Hi Torque On/Off Motor	1
16	VE4988	4 Second 12 Volt Hi Torque Motor	1
16	VE49892	6 Second 12 Volt 2 Wire HT Motor	1
17	MVE107	EV Motor Shaft Gasket 1/2" ID	1
18	MVE002	Heyco 1/4" Threaded Bushing	1
19	MVE104	Outer EV Housing Gasket	1
20	VE109E	Indicator Seal	1
21	MVE007	3mm X 5mm FKM O-Ring	1
22	MVE106	Inner EV Housing Gasket	1
23	VE107A	EV Flow Indicator	1
24	MEV25101	EV Housing Bottom for Large Motor	1
25	EV20210	Repair Kit (Includes Parts 2, 9, 10, 12)	1

The Spray Tech part number can be derived by adding the prefix 'TE' to the listed Banjo part numbers.



Electric Valves 2" Full Port Threaded

FEATURES

- 316 stainless steel ball & stem.
- Stainless steel hardware.
- Fiberglass reinforced polypropylene.
- Glass reinforced PTFE seats.
- FKM (viton type) or EPDM O-rings.
- 12-volt DC operated.
- 150 P.S.I. maximum pressure @ 70°F.
- Easily repairable.
- Open/closed indicator.



ON/OFF Electric Valves - 1 1/4 Second Response Time

PART NO.	DESCRIPTION	MAX. PSI	PIPE SIZE	OPENING THRU BALL	QUANTITY
EV204FP	2" FP Electric Valve	150	2"	2"	1

ON/OFF WIRING DIAGRAM

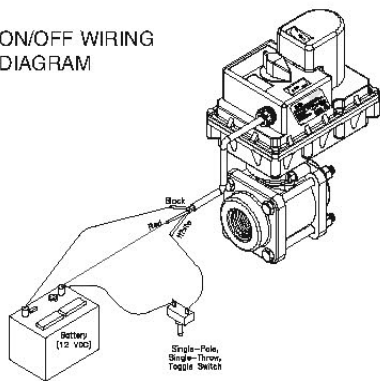

REGULATING WIRING DIAGRAM

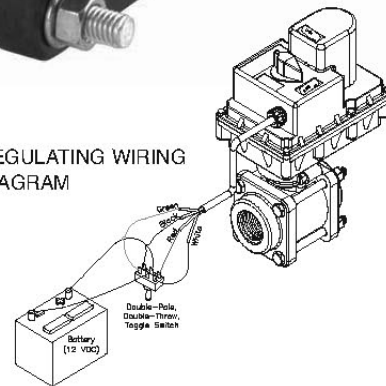

REGULATING Electric Valves - 4 Second Response Time

PART NO.	DESCRIPTION	MAX. PSI	PIPE SIZE	OPENING THRU BALL	QUANTITY
EVR204FP	2" FP Electric Valve	150	2"	2"	1



The Spray Tech part number can be derived by adding the prefix 'TE' to the listed Banjo part numbers.



ELECTRIC VALVES

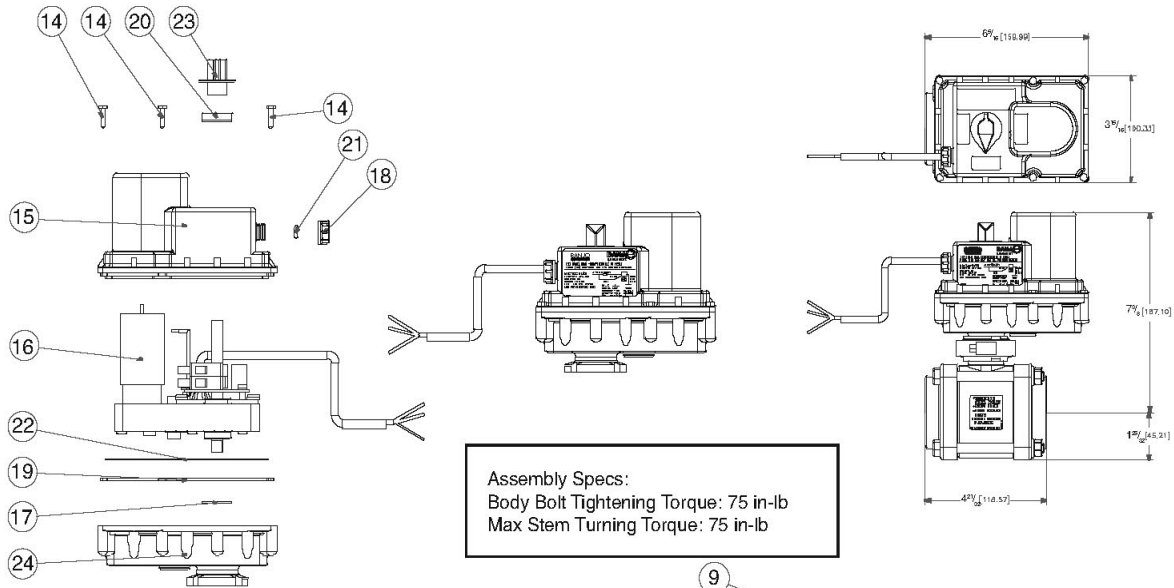

Fast repair replacement options.

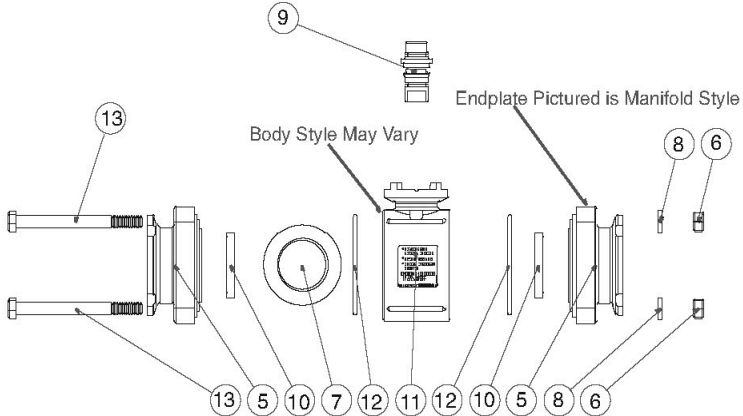
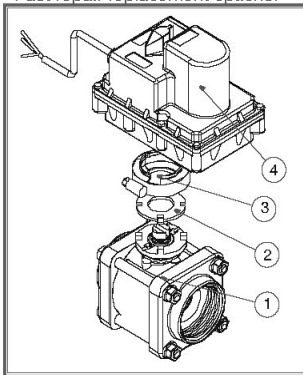

REPLACEMENT PARTS EV204FP - EVR204FP			
ITEM	PART NO.	DESCRIPTION	QTY.
1	EV204XR1	2" FP Electric Valve Sub Assembly	1
2	MVE004	Electric Valve Flange Gasket	1
3	FC100	1" Flange clamp	1
4	EV4100	1 1/4" Second 3 Wire Motor Assembly	1
4	EVR4100	Regulating 4 Wire, 4 Second	1
4	EVR4102	Regulating 2 Wire, 6 Second	1
5	VE25358A	2" FP Threaded Endplate for EV	2
6	V20019	3/8" Stainless Steel Body Nut	4
7	VE25255SSH	2" EV 316 Stainless Steel Hollow Ball	1
8	V20018	3/8" Stainless Steel Lock Washer	4
9	MEV25151	1" Stainless Steel Stem w/Seals	1
10	VE25258A	1 1/2" & 2" Electric Ball Seat	2
11	MEV25254A	EV Body 1 1/2" & 2"	1
12	V25264	2" EV Body FKM O-Ring	2
13	V25017	3/8" X 4" Stainless Steel Body Bolt	4

REPLACEMENT PARTS EV204FP - EVR204FP			
ITEM	PART NO.	DESCRIPTION	QTY.
14	VE15220	Housing Screw	6
15	MVE25102	EV Housing Top for Large Motor	1
16	VE4987	1 1/4" Hi Torque On/Off Motor	1
16	VE4988	4 Second 12 Volt Hi Torque Motor	1
17	MVE107	EV Motor Shaft Gasket 1/2" ID	1
18	MVE002	Heyco 1/4" Threaded Bushing	1
19	MVE104	Outer EV Housing Gasket	1
20	VE109E	Indicator Seal	1
21	MVE007	3mm X 5mm FKM O-Ring	1
22	MVE106	Inner EV Housing Gasket	1
23	VE107A	EV Flow Indicator	1
24	MEV25101	EV Housing Bottom for Large Motor	1
25	EV25210	Repair Kit (Includes Parts 2, 9, 10, 12)	1

The Spray Tech part number can be derived by adding the prefix 'TE' to the listed Banjo part numbers.



3-Way Electric Valves

3/4", 1", 1 1/4" Threaded w/Flanged Inlet

FEATURES

- 316 stainless steel ball & stem.
- Stainless steel hardware.
- Fiberglass reinforced polypropylene.
- Glass reinforced PTFE seats.
- FKM (viton type) or EPDM O-rings.
- 12-volt DC operated.
- 150 P.S.I. maximum pressure @ 70°F.
- Easily repairable.
- Open/closed indicator.

BOTTOM LOAD:

Directional flow right or left.

Valve flow cannot be turned off.

3/4 SECOND RESPONSE TIME

PART NO.	DESCRIPTION	MAX. PSI	PIPE SIZE	OPENING THRU BALL	QUANTITY
EV075BL	3/4" Electric Valve x 1" Inlet Flange	150	3/4"	1"	1
EV100BL	1" Electric Valve x 1" Inlet Flange	150	1"	1"	1
EV125BL	1 1/4" Electric Valve x 1" Inlet Flange	150	1 1/4"	1"	1



BOTTOM LOAD

SIDE LOAD:

Directional flow right or left.

Valve flow cannot be turned off.

3/4 SECOND RESPONSE TIME

PART NO.	DESCRIPTION	MAX. PSI	PIPE SIZE	OPENING THRU BALL	QUANTITY
EV075SL	3/4" Electric Valve x 1" Inlet Flange	150	3/4"	1"	1
EV100SL	1" Electric Valve x 1" Inlet Flange	150	1"	1"	1
EV125SL	1 1/4" Electric Valve x 1" Inlet Flange	150	1 1/4"	1"	1



SIDE LOAD

ON/OFF WIRING DIAGRAM

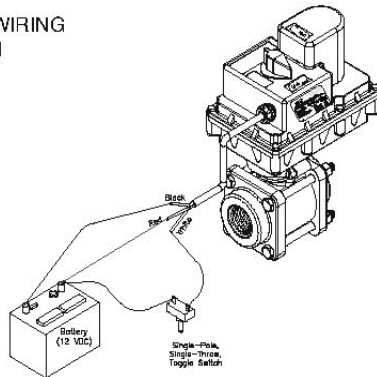

REGULATING WIRING DIAGRAM

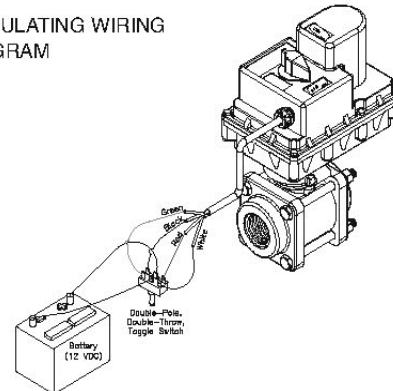

Attention:

3-Way regulating valves are not shown, but are available.

Standard 3-Way valves use the On/Off wiring diagram.



The Spray Tech part number can be derived by adding the prefix 'TE' to the listed Banjo part numbers.



ELECTRIC VALVES

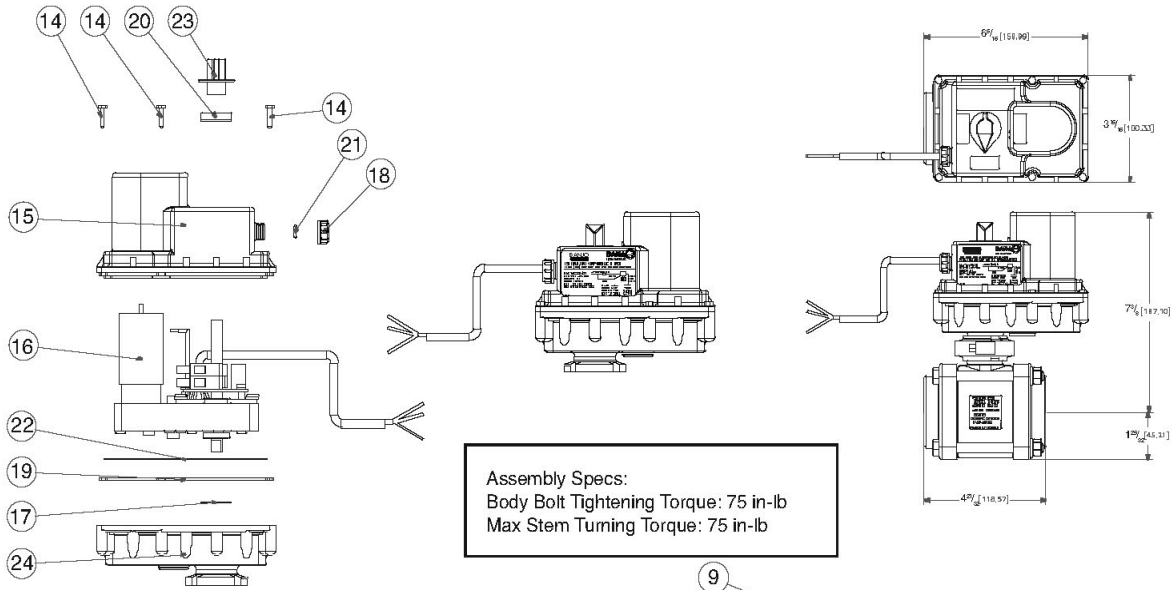

Assembly Specs:
 Body Bolt Tightening Torque: 75 in-lb
 Max Stem Turning Torque: 75 in-lb

Fast repair replacement options.

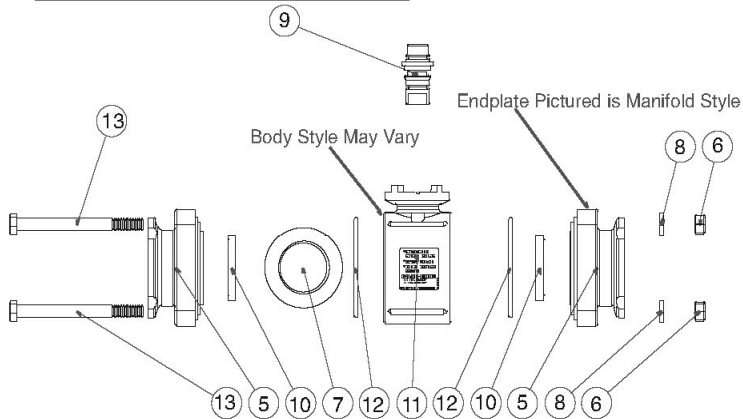
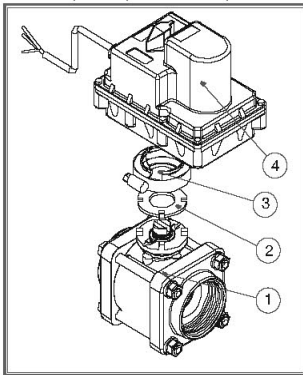

REPLACEMENT PARTS EV075SL - EV075BL - EV100SL - EV100BL EV125SL - EV125BL			
ITEM	PART NO.	DESCRIPTION	QTY.
1	EV075SLXR1	3/4" Electric Valve Sub Assembly	1
1	EV100SLXR1	1" FP Electric Valve Sub Assembly	1
1	EV125SLXR1	1 1/4" Electric Valve Sub Assembly	1
1	EV075BLXR1	3/4" Electric Valve Sub Assembly	1
1	EV100BLXR1	1" FP Electric Valve Sub Assembly	1
1	EV125BLXR1	1 1/4" Electric Valve Sub Assembly	1
2	MVE004	Electric Valve Flange Gasket	1
3	FC100	1" Flange clamp	1
4	EV3100	3/4 Second 3 Wire Motor Assembly	1
4	EVR3100	Regulating 4 Wire, 4 Second	1
5	VE07357	3/4" Threaded Endplate for EV	2
5	VE10257A	1" FP Threaded Endplate for EV	2
5	VE10256A	1 1/4" Threaded Endplate for EV	2
6	V10119	5/16" Stainless Steel Body Nut	4
7	VE10355	1" EV 316 Stainless Steel Hollow Ball	1
8	V10118	5/16" Stainless Steel Lock Washer	4
9	MEV10151	1" Stainless Steel Stem w/Seals	1
10	VE10258A	1" Electric Ball Seat	2

REPLACEMENT PARTS EV075SL - EV075BL - EV100SL - EV100BL EV125SL - EV125BL			
ITEM	PART NO.	DESCRIPTION	QTY.
11	MEV10354AB	EV BL Body 3/4" - 1 1/4"	1
11	MEV10354AS	EV SL Body 3/4" - 1 1/4"	1
12	VE10264	Body O-Ring	2
13	V10117	5/16" X 3 1/2" SS Body Bolt	4
14	VE15220	Housing Screw	6
15	MEV10102	EV Housing Top for Small Motor	1
16	VE4984	3/4" Hi Torque On/Off Motor	1
16	VE4983	4 Second 4 Wire 12 Volt HT Motor	1
17	MVE105VE	Motor Shaft Gasket 1/2" ID	1
18	MVE002	Heyco 1/4" Threaded Bushing	1
19	MVE104	Outer EV Housing Gasket	1
20	VE109E	Indicator Seal	1
21	MVE007	3mm X 5mm FKM O-Ring	1
22	MVE106	Inner EV Housing Gasket	1
23	VE107A	EV Flow Indicator	1
24	MEV10101	EV Housing Bottom for Large Motor	1
25	EV10210	Repair Kit (Includes Parts 2, 9, 10, 12)	1

The Spray Tech part number can be derived by adding the prefix 'TE' to the listed Banjo part numbers.



3-Way Electric Valves

1 1/2" 2" Threaded w/Flanged Inlet

FEATURES

- 316 stainless steel ball & stem.
- Stainless steel hardware.
- Fiberglass reinforced polypropylene.
- Glass reinforced PTFE seats.
- FKM (viton type) or EPDM O-rings.
- 12-volt DC operated.
- 150 P.S.I. maximum pressure @ 70°F.
- Easily repairable.
- Open/closed indicator.

BOTTOM LOAD:

Directional flow right or left.

Valve flow cannot be turned off.

1 1/4 SECOND RESPONSE TIME

PART NO.	DESCRIPTION	MAX. PSI	PIPE SIZE	OPENING THRU BALL	QUANTITY
EV150BL	1 1/2" X 2" Standard Port Flange	150	1 1/2"	1 1/2"	1
EV200BL	2" X 2" Standard Port Flange	150	2"	1 1/2"	1



BOTTOM LOAD

SIDE LOAD:

Directional flow right or left.

Valve flow cannot be turned off.

1 1/4 SECOND RESPONSE TIME

PART NO.	DESCRIPTION	MAX. PSI	PIPE SIZE	OPENING THRU BALL	QUANTITY
EV150SL	1 1/2" X 2" Standard Port Flange	150	1 1/2"	1 1/2"	1
EV200SL	2" X 2" Standard Port Flange	150	2"	1 1/2"	1



SIDE LOAD

ON/OFF WIRING DIAGRAM

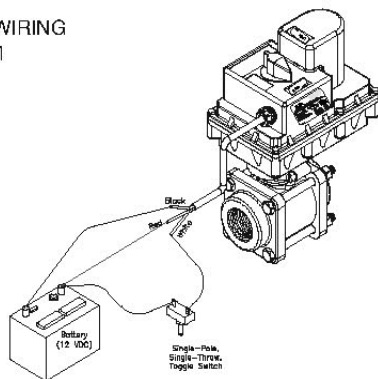

REGULATING WIRING DIAGRAM

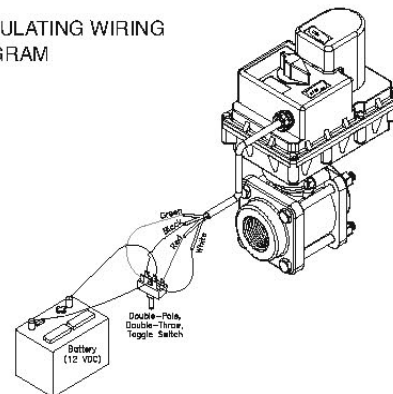

Attention:

3-Way regulating valves are not shown, but are available.
Standard 3-Way valves use the On/Off wiring diagram.



The Spray Tech part number can be derived by adding the prefix 'TE' to the listed Banjo part numbers.



ELECTRIC VALVES

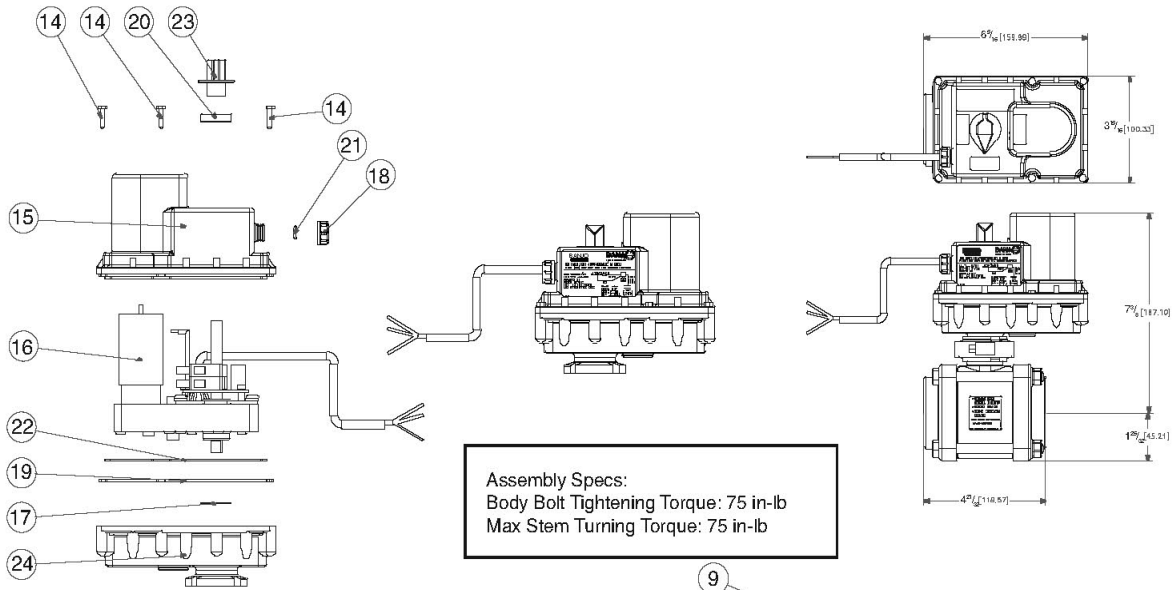

Fast repair replacement options.

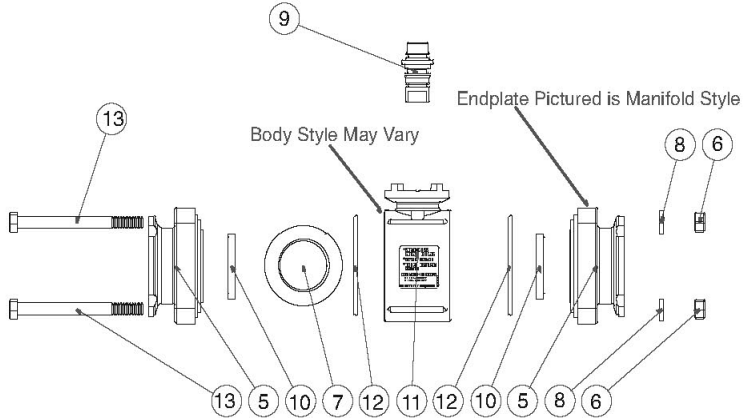
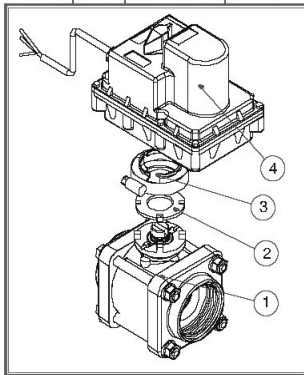

REPLACEMENT PARTS EV150SL - EV200SL - EVR150BL - EVR200BL			
ITEM	PART NO.	DESCRIPTION	QTY.
1	EV150SLXR1	1 1/2" FP Electric Valve Sub Assembly	1
1	EV200SLXR1	2" Electric Valve Sub Assembly	1
1	EV150BLXR1	1 1/2" FP Electric Valve Sub Assembly	1
1	EV200BLXR1	2" Electric Valve Sub Assembly	1
2	MVE004	Electric Valve Flange Gasket	1
3	FC100	1" Flange clamp	1
4	EV4100	1 1/4 Second 3 Wire Motor Assembly	1
4	EVR4100	Regulating 4 Wire, 4 Second	1
5	VE20257	1 1/2" Threaded Endplate for EV	2
5	VE20256	2" Threaded Endplate for EV	2
6	V20019	3/8" Stainless Steel Body Nut	4
7	VE20355	2v EV 316 Stainless Steel Ball	1
8	V20018	3/8" Stainless Steel Lock Washer	4
9	MEV10151	1" Stainless Steel Stem w/Seals	1
10	VE20258	1 1/2" & 2" Electric Ball Seat	2
11	MEV20354AS	EV SL Body 1 1/2" & 2"	1
11	MEV20354AB	EV BL Body 1 1/2" & 2"	1

REPLACEMENT PARTS EV150SL - EV200SL - EVR150BL - EVR200BL			
ITEM	PART NO.	DESCRIPTION	QTY.
12	VE20264	2" EV Body FKM O-Ring	2
13	V20017	3/8" X 4" Stainless Steel Body Bolt	4
14	VE15220	Housing Screw	6
15	MVE25102	EV Housing Top for Large Motor	1
16	VE4987	1 1/4" Hi Torque On/Off Motor	1
16	VE4988	4 Second 12 Volt Hi Torque Motor	1
17	MVE107	EV Motor Shaft Gasket 1/2" ID	1
18	MVE002	Heyco 1/4" Threaded Bushing	1
19	MVE104	Outer EV Housing Gasket	1
20	VE109E	Indicator Seal	1
21	MVE007	3mm X 5mm FKM O-Ring	1
22	MVE106	Inner EV Housing Gasket	1
23	VE107A	EV Flow Indicator	1
24	MEV25101	EV Housing Bottom for Large Motor	1
25	EV20210	Repair Kit (Includes Parts 2, 9, 10, 12)	1

The Spray Tech part number can be derived by adding the prefix 'TE' to the listed Banjo part numbers.



3-Way Electric Valves

2" Full Port Threaded w/Flanged Inlet

FEATURES

- 316 stainless steel ball & stem.
- Stainless steel hardware.
- Fiberglass reinforced polypropylene.
- Glass reinforced PTFE seats.
- FKM (viton type) or EPDM O-rings.
- 12-volt DC operated.
- 150 P.S.I. maximum pressure @ 70°F.
- Easily repairable.
- Open/closed indicator.

BOTTOM LOAD:

Directional flow right or left.
Valve flow cannot be turned off.

1 1/4 SECOND RESPONSE TIME

PART NO.	DESCRIPTION	MAX. PSI	PIPE SIZE	OPENING THRU BALL	QUANTITY
EV204BLFP	2" Electric Valve x 2" Full Port Flange	150	2"	2"	1



BOTTOM LOAD

SIDE LOAD:

Directional flow right or left.
Valve flow cannot be turned off.

1 1/4 SECOND RESPONSE TIME

PART NO.	DESCRIPTION	MAX. PSI	PIPE SIZE	OPENING THRU BALL	QUANTITY
EV204SLFP	2" Electric Valve x 2" Full Port Flange	150	2"	2"	1



SIDE LOAD

ON/OFF WIRING DIAGRAM

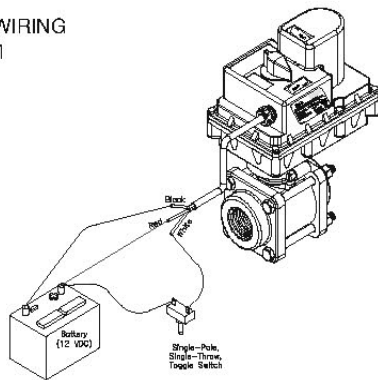

REGULATING WIRING DIAGRAM

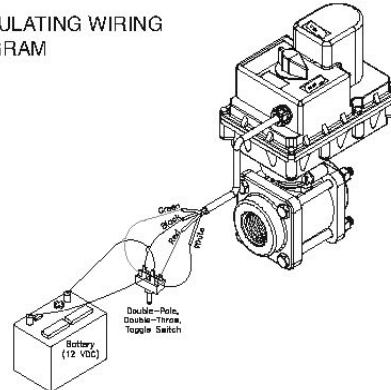

Attention:
3-Way regulating valves are not shown, but are available.
Standard 3-Way valves use the On/Off wiring diagram.



The Spray Tech part number can be derived by adding the prefix 'TE' to the listed Banjo part numbers.



ELECTRIC VALVES

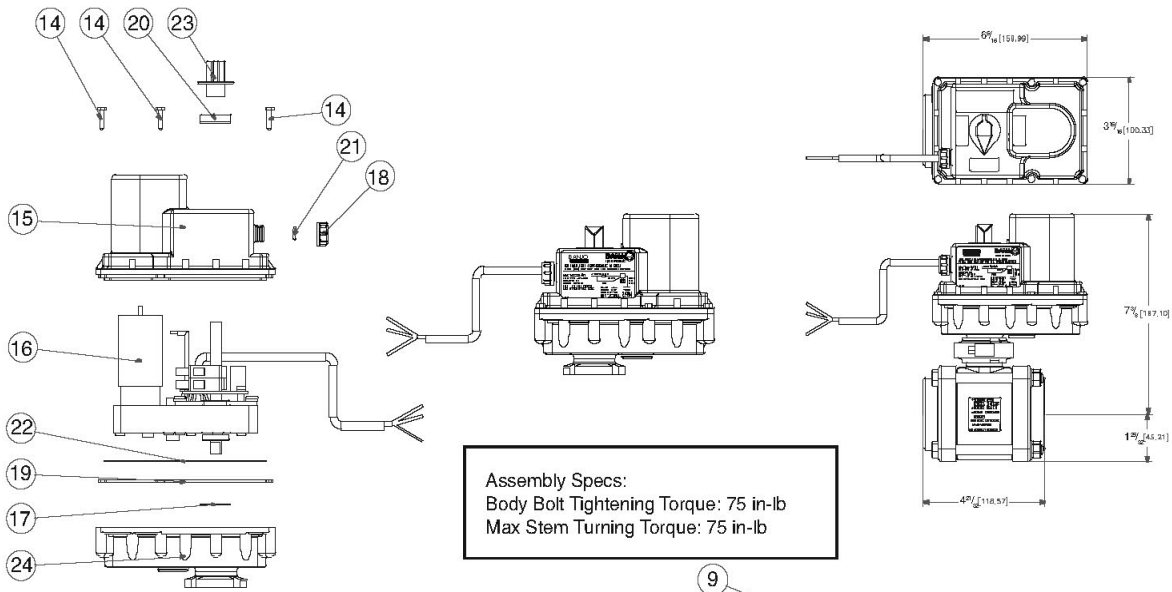

Assembly Specs:
 Body Bolt Tightening Torque: 75 in-lb
 Max Stem Turning Torque: 75 in-lb

Fast repair replacement options.

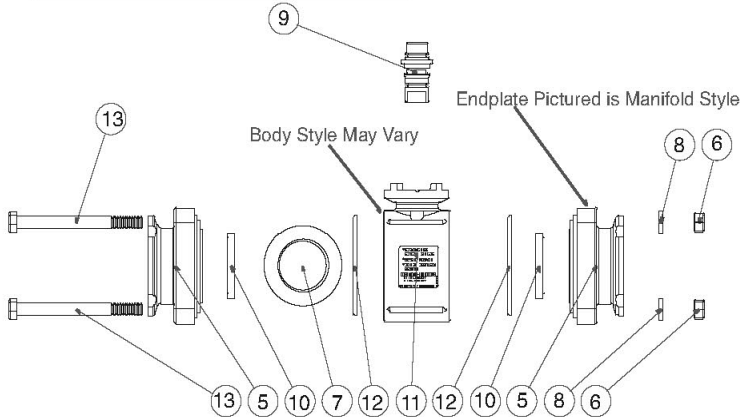
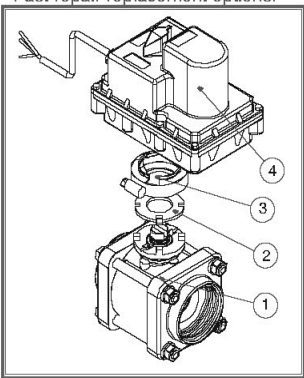

REPLACEMENT PARTS EV204SLFP - EVR204BLFP			
ITEM	PART NO.	DESCRIPTION	QTY.
1	EV204SLXR1	2" FP SL Electric Valve Sub Assembly	1
1	EV204BLXR1	2" FP BL Electric Valve Sub Assembly	1
2	MVE004	Electric Valve Flange Gasket	1
3	FC100	1" Flange clamp	1
4	EV4100	1 1/4 Second 3 Wire motor Assembly	1
4	EVR4100	Regulating 4 Wire, 4 Second	1
5	VE25358A	2" FP Threaded Endplate for EV	2
6	V20019	3/8" Stainless Steel Body Nut	4
7	VE25355	2" EV 316 Stainless Steel Ball	1
8	V20018	3/8" Stainless Steel Lock Washer	4
9	MEV25151	1" Stainless Steel Stem w/Seals	1
10	VE25258A	1 1/2" & 2" Electric Ball Seat	2
11	MEV25354AS	EV SL Body 1 1/2" & 2"	1
11	MEV25354AB	EV BL Body 1 1/2" & 2"	1
12	V25264	2" EV Body FKM O-Ring	2

REPLACEMENT PARTS EV204SLFP - EVR204BLFP			
ITEM	PART NO.	DESCRIPTION	QTY.
13	V25017	3/8" X 4 1/2" Stainless Steel Body Bolt	4
14	VE15220	Housing Screw	6
15	MVE25102	EV Housing Top for Large Motor	1
16	VE4987	1 1/4" Hi Torque On/Off Motor	1
16	VE4988	4 Second 12 Volt Hi Torque Motor	1
17	MVE107	EV Motor Shaft Gasket 1/2" ID	1
18	MVE002	Heyco 1/4" Threaded Bushing	1
19	MVE104	Outer EV Housing Gasket	1
20	VE109E	Indicator Seal	1
21	MVE007	3mm X 5mm FKM O-Ring	1
22	MVE106	Inner EV Housing Gasket	1
23	VE107A	EV Flow Indicator	1
24	MEV25101	EV Housing Bottom for Large Motor	1
25	EV25210	Repair Kit (Includes Parts 2, 9, 10, 12)	1

The Spray Tech part number can be derived by adding the prefix 'TE' to the listed Banjo part numbers.

1" Banjo Electric Manifold Valve Assemblies

2 Valve Manifold



2 VALVE MANIFOLD ASSEMBLY (M200 SERIES)

PART NO.	DESCRIPTION	MAX PSI	PIPE SIZE	QUANTITY
MEV102CF	1" Manifold Valve Assembly 2" inlet flanges, 1" outlet flanges	150	2" IN 1" OUT	1/per box

3 Valve Manifold



3 VALVE MANIFOLD ASSEMBLY (M200 SERIES)

PART NO.	DESCRIPTION	MAX PSI	PIPE SIZE	QUANTITY
MEV103CF	1" Manifold Valve Assembly 2" inlet flanges, 1" outlet flanges	150	2" IN 1" OUT	1/per box

**3 VALVE MANIFOLD ASSEMBLY (M200 SERIES)
WITH MOUNTING BRACKETS**

PART NO.	DESCRIPTION	MAX PSI	PIPE SIZE	QTY.
MEV103MB	1" Manifold Valve Assembly 2" inlet flanges, 1" outlet flanges with Bracket	150	2" IN 1" OUT	1



FLANGED MOUNTING BRACKET TEE

PART NO.	DESCRIPTION	QTY.
M200100TEEB	2"x1" Std. Port. Flanged Tee w/Mtg Bracket	1

4 Valve Manifold



4 VALVE MANIFOLD ASSEMBLY (M200 SERIES)

PART NO.	DESCRIPTION	MAX PSI	PIPE SIZE	QUANTITY
MEV104CF	1" Manifold Valve Assembly 2" inlet flanges, 1" outlet flanges	150	2" IN 1" OUT	1/per box

5 Valve Manifold



5 VALVE MANIFOLD ASSEMBLY (M200 SERIES)

PART NO.	DESCRIPTION	MAX PSI	PIPE SIZE	QUANTITY
MEV105CF	1" Manifold Valve Assembly 2" inlet flanges, 1" outlet flanges	150	2" IN 1" OUT	1/per box

The Spray Tech part number can be derived by adding the prefix 'TE' to the listed Banjo part numbers.



Electric Manifold Valves

1" 2" Standard Port & 2" Full Port

FEATURES

- 316 stainless steel ball & stem.
- Fiberglass reinforced polypropylene.
- Glass reinforced PTFE seats.
- FKM (viton type) or EPDM O-rings.
- 12-volt DC operated.
- 150 P.S.I. maximum pressure.
- Internally fused/automatic reset.
- Open/closed indicator.



ON/OFF ELECTRIC VALVES $\frac{3}{4}$ to $1\frac{1}{4}$ RESPONSE TIME

PART NO.	DESCRIPTION	MAX. PSI	FLANGE SIZE	OPENING THRU BALL	QUANTITY
MEV100CF	1" Full Port Electric Ball Valve	150	1"	1"	1
MEV200CF	2" Standard Port Electric Ball Valve	150	2" Std Port	1 $\frac{1}{2}$ "	1
MEV220CF	2" Full Port Electric Ball Valve	150	2" Full Port	2"	1

ON/OFF WIRING DIAGRAM

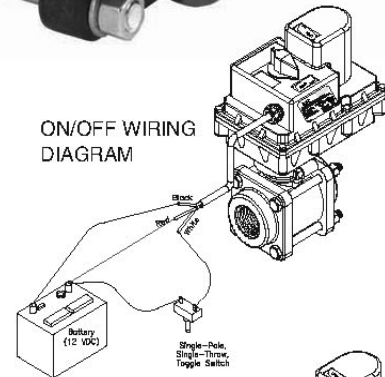

REGULATING ELECTRIC VALVES - 4 SECOND RESPONSE TIME

PART NO.	DESCRIPTION	MAX. PSI	FLANGE SIZE	OPENING THRU BALL	QUANTITY
MEVR100CF	1" Full Port Electric Ball Valve	150	1"	1"	1
MEVR200CF	2" Standard Port Electric Ball Valve	150	2" Std Port	1 $\frac{1}{2}$ "	1
MEVR220CF	2" Full Port Electric Ball Valve	150	2" Full Port	2"	1

REGULATING WIRING DIAGRAM

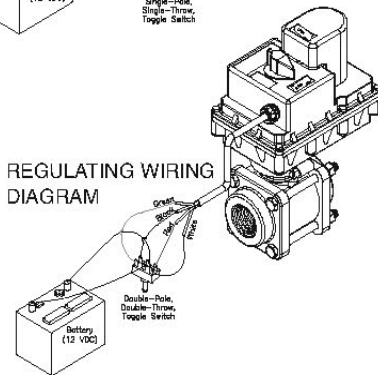

The Spray Tech part number can be derived by adding the prefix 'TE' to the listed Banjo part numbers.

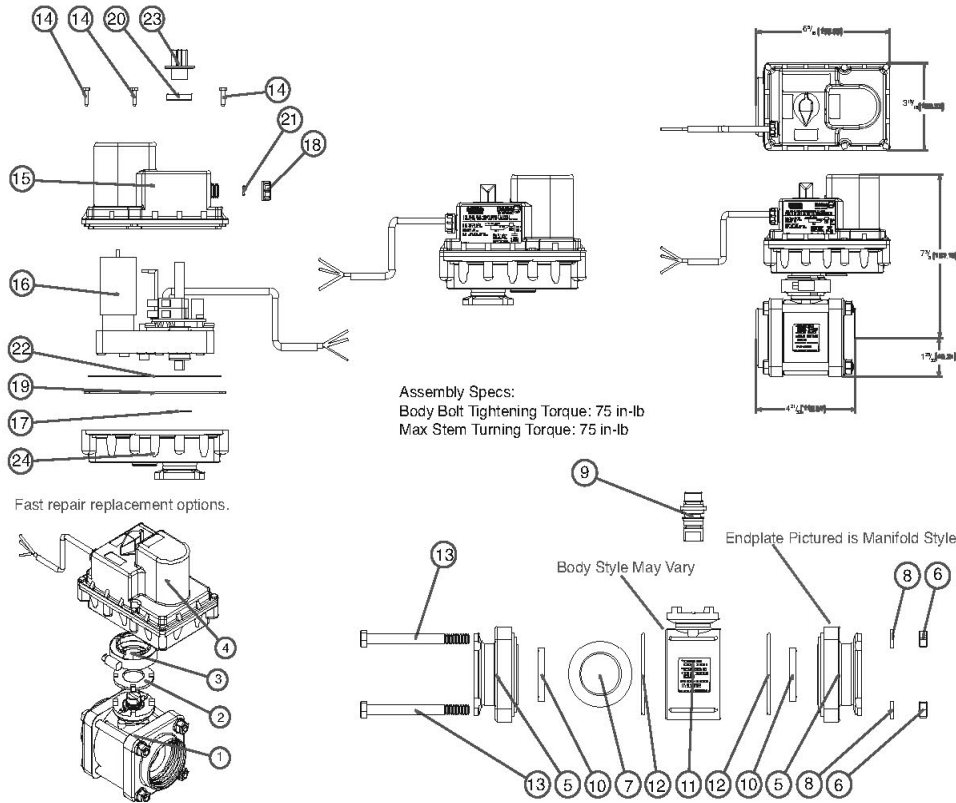

REPLACEMENT PARTS MEV100CF - MEV200CF - MEV220CF			
ITEM	PART NO.	DESCRIPTION	QTY.
1	MEV100XR1	1" FP Electric Valve Sub Assembly	1
1	MEV200XR1	2" Electric Valve Sub Assembly	1
1	MEV220XR1	2" FP Electric Valve Sub Assembly	1
2	MVE004	Electric Valve Flange Gasket	1
3	FC100	1" Flange clamp	1
4	EV3100	1" 3/4 Second 3 Wire Motor Assembly	1
4	EV4100	2" 1 1/4 Second 3 Wire Motor Assembly	1
5	VE10278A	1" Manifold Endplate for EV	2
5	VE20294A	2" Manifold Endplate for EV	2
5	VE25378A	2" FP Manifold Endplate for EV	2
6	V10119	5/16" Stainless Steel Body Nut (1")	4
6	V20019	3/8" Stainless Steel Body Nut (2")	4
7	VE10155SSH	1" EV 316 Stainless Steel Hollow Ball	1
7	VE20255SSH	2" EV 316 Stainless Steel Hollow Ball	1
7	VE25255SSH	2" FP EV 316 Stainless Steel Hollow Ball	1
8	V10118	5/16" Stainless Steel Lock Washer (1")	4
8	V20018	3/8" Stainless Steel Lock Washer (2")	4
9	MEV10151	1" Stainless Steel Stem w/Seals	1
9	MEV25151	2" Stainless Steel Stem w/Seals	1
10	VE10258A	1" Electric Ball Seat	2
10	VE20258A	2" Electric Ball Seat	2
10	VE25258	2" FP Electric Ball Seat	2
11	MEV10254A	EV Body 1"	1
11	MEV20254A	EV Body 2"	1
11	MEV25254A	EV Body 2" FP	1

REPLACEMENT PARTS MEV100CF - MEV200CF - MEV220CF			
ITEM	PART NO.	DESCRIPTION	QTY.
12	VE10264	1" EV Body FKM O-Ring	2
12	VE20264	2" EV Body FKM O-Ring	2
12	V25264	2" FP EV Body FKM O-Ring	2
13	V10117	5/16" X 3 1/2" SS Body Bolt	4
13	V20017	3/8" X 4" SS Body Bolt (2")	4
13	V25017	3/8" X 4 1/2" SS Body Bolt (2" FP)	4
14	VE15220	Housing Screw	6
15	MVE10102	EV Housing Top for Small Motor (1")	1
15	MVE25102	EV Housing Top for Large Motor(2")	1
16	VE4984	3/4" Second On/Off Motor (1")	1
16	VE4987	1 1/4" Second On/Off Motor (2")	1
17	MVE107	EV Motor Shaft Gasket 1/2" ID	1
18	MVE002	Heyco 1/4" Threaded Bushing	1
19	MVE104	Outer EV Housing Gasket	1
20	VE109E	Indicator Seal	1
21	MVE007	3mm X 5mm FKM O-Ring	1
22	MVE106	Inner EV Housing Gasket	1
23	VE107A	EV Flow Indicator	1
24	MEV10101	1" EV Housing Bottom for Large Motor	1
24	MEV25101	2" EV Housing Bottom for Large Motor	1
25	EV10210	1" Repair Kit (Includes Parts 2, 9, 10, 12)	1
25	EV20210	2" Repair Kit (Includes Parts 2, 9, 10, 12)	1
25	EV25210	2" FP Repair Kit (Includes Parts 2, 9, 10, 12)	1

The Spray Tech part number can be derived by adding the prefix 'TE' to the listed Banjo part numbers.



3-Way Side Load Electric Manifold Valves 1" 1 1/2" & 2" Full Port

FEATURES

- 316 stainless steel ball & stem.
- Fiberglass reinforced polypropylene.
- Glass reinforced PTFE seats.
- FKM (viton type) or EPDM O-rings.
- 12-volt DC operated.
- 150 P.S.I. maximum pressure.
- Internally fused/automatic reset.
- Open/closed indicator.



SIDE LOAD:
DIRECTIONAL FLOW LEFT OR RIGHT. VALVE FLOW CANNOT BE TURNED OFF.

ON/OFF ELECTRIC VALVES ³/₄ to ¹/₄ RESPONSE TIME

PART NO.	DESCRIPTION	MAX. PSI	FLANGE SIZE	OPENING THRU BALL	QUANTITY
MEV100SLCF	1" Full Port Electric Ball Valve	150	1"	1"	1
MEV200SLCF	2" Standard Port Electric Ball Valve	150	2" Std Port	1 1/2"	1
MEV220SLCF	2" Full Port Electric Ball Valve	150	2" Full Port	2"	1

ON/OFF WIRING DIAGRAM

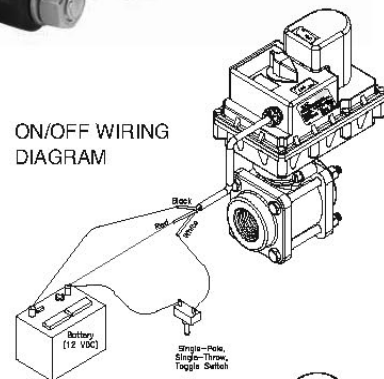

REGULATING ELECTRIC VALVES - 4 SECOND RESPONSE TIME

PART NO.	DESCRIPTION	MAX. PSI	FLANGE SIZE	OPENING THRU BALL	QUANTITY
MEVR100SLCF	1" Full Port Electric Ball Valve	150	1"	1"	1
MEVR200SLCF	2" Standard Port Electric Ball Valve	150	2" Std Port	1 1/2"	1
MEVR220SLCF	2" Full Port Electric Ball Valve	150	2" Full Port	2"	1

REGULATING WIRING DIAGRAM

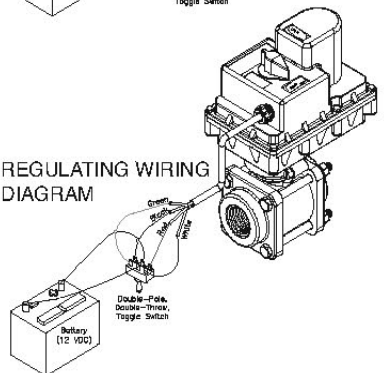

The Spray Tech part number can be derived by adding the prefix 'TE' to the listed Banjo part numbers.

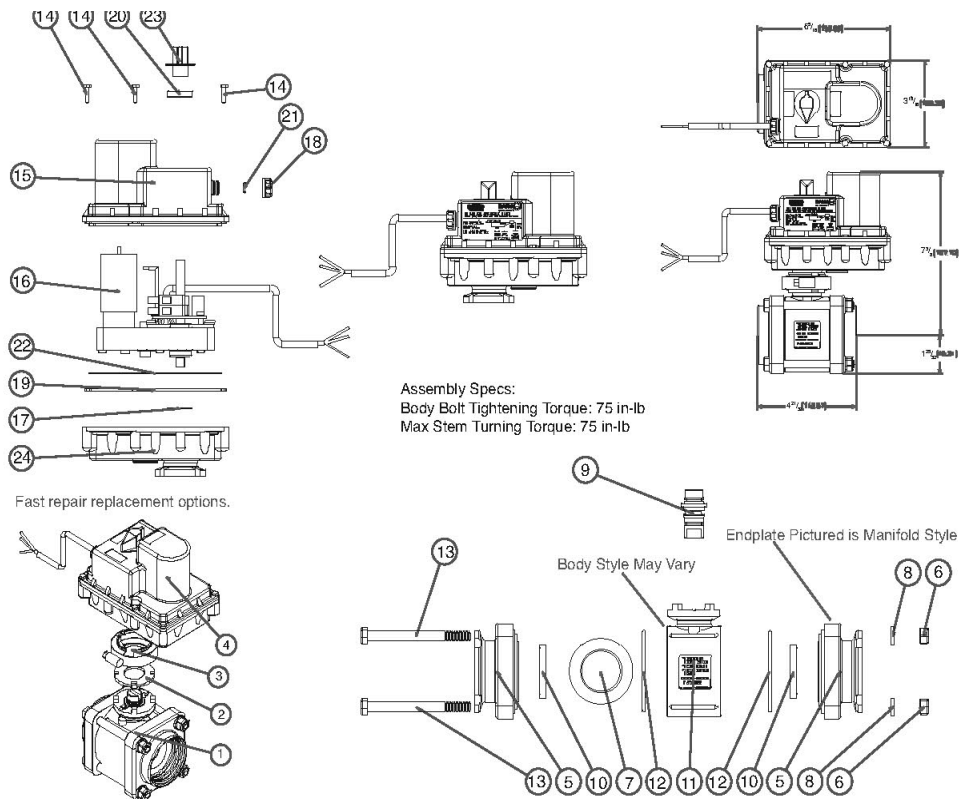

REPLACEMENT PARTS MEV100SLCF - MEV200SLCF - MEV220SLCF			
ITEM	PART NO.	DESCRIPTION	QTY.
1	MEV100SLXR1	1" FP Electric Valve Sub Assembly	1
1	MEV200SLXR1	2" Electric Valve Sub Assembly	1
1	MEV220SLXR1	2" FP Electric Valve Sub Assembly	1
2	MVE004	Electric Valve Flange Gasket	1
3	FC100	1" Flange Clamp	1
4	EV3100	1" 3/4 Second 3 Wire Motor Assembly	1
4	EV4100	2" 1 1/4 Second 3 Wire Motor Assembly	1
5	VE10278A	1" Manifold Endplate for EV	2
5	VE20294	2" Manifold Endplate for EV	2
5	VE25378A	2" FP Manifold Endplate for EV	2
6	V10119	5/16" Stainless Steel Body Nut (1")	4
6	V20019	3/8" Stainless Steel Body Nut (2")	4
7	VE10355	1" EV 316 Stainless Steel Hollow Ball	1
7	VE20355	2" EV 316 Stainless Steel Hollow Ball	1
7	VE25355	2" FP EV 316 Stainless Steel Hollow Ball	1
8	V10118	5/16" Stainless Steel Lock Washer (1")	4
8	V20018	3/8" Stainless Steel Lock Washer (2")	4
9	MEV10151	1" Stainless Steel Stem w/Seals	1
9	MEV25151	2" Stainless Steel Stem w/Seals	1
10	VE10258A	1" Electric Ball Seat	2
10	VE20258	2" Electric Ball Seat	2
10	VE25258A	2" FP Electric Ball Seat	2
11	MEV10354AS	EV Body 1"	1
11	MEV20354AS	EV Body 2"	1
11	MEV25354AS	EV Body 2" FP	1

REPLACEMENT PARTS MEV100SLCF - MEV200SLCF - MEV220SLCF			
ITEM	PART NO.	DESCRIPTION	QTY.
12	VE10264	1" EV Body FKM O-Ring	2
12	VE20264	2" EV Body FKM O-Ring	2
12	V25264	2" FP EV Body FKM O-Ring	2
13	V10117	5/16" X 3 1/2" SS Body Bolt	4
13	V20017	3/8" X 4" SS Body Bolt (2")	4
13	V25017	3/8" X 4 1/2" SS Body Bolt (2" FP)	4
14	VE15220	Housing Screw	6
15	MVE10102	EV Housing Top for Small Motor (1")	1
15	MVE25102	EV Housing Top for Large Motor (2")	1
16	VE4984	3/4" Second On/Off Motor (1")	1
16	VE4987	1 1/4" Second On/Off Motor (2")	1
17	MVE107	EV Motor Shaft Gasket 1/2" ID	1
18	MVE002	Heyco 1/4" Threaded Bushing	1
19	MVE104	Outer EV Housing Gasket	1
20	VE109E	Indicator Seal	1
21	MVE007	3mm X 5mm FKM O-Ring	1
22	MVE106	Inner EV Housing Gasket	1
23	VE107A	EV Flow Indicator	1
24	MEV10101	1" EV Housing Bottom for Large Motor	1
24	MEV25101	2" EV Housing Bottom for Large Motor	1
25	EV10210	1" Repair Kit (Includes Parts 2, 9, 10, 12)	1
25	EV20210	2" Repair Kit (Includes Parts 2, 9, 10, 12)	1
25	EV25210	2" FP Repair Kit (Includes Parts 2, 9, 10, 12)	1

The Spray Tech part number can be derived by adding the prefix 'TE' to the listed Banjo part numbers.



3-Way Bottom Load Electric Manifold Valves 1", 1 1/2" & 2" Full Port

FEATURES

- 316 stainless steel ball & stem.
- Fiberglass reinforced polypropylene.
- Glass reinforced PTFE seats.
- FKM (viton type) or EPDM O-rings.
- 12-volt DC operated.
- 150 P.S.I. maximum pressure.
- Internally fused/automatic reset.
- Open/closed indicator.

ON/OFF WIRING DIAGRAM

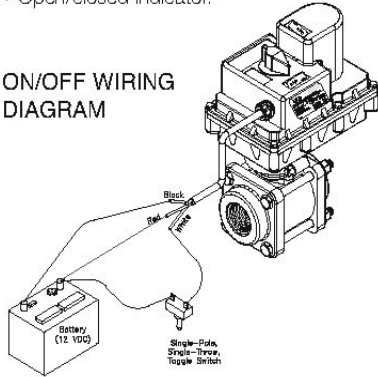

ON/OFF ELECTRIC VALVES $3/4$ to $1 1/4$ RESPONSE TIME

PART NO.	DESCRIPTION	MAX. PSI	FLANGE SIZE	OPENING THRU BALL	QUANTITY
MEV100BLCF	1" Full Port Electric Ball Valve	150	1"	1"	1
MEV200BLCF	2" Stand. Port Electric Ball Valve	150	2" Std Port	1 1/2"	1
MEV220BLCF	2" Full Port Electric Ball Valve	150	2" Full Port	2"	1

NOTE: NO Regulating Valve available for 3-way bottom load electric manifold valves.

The Spray Tech part number can be derived by adding the prefix 'TE' to the listed Banjo part numbers.

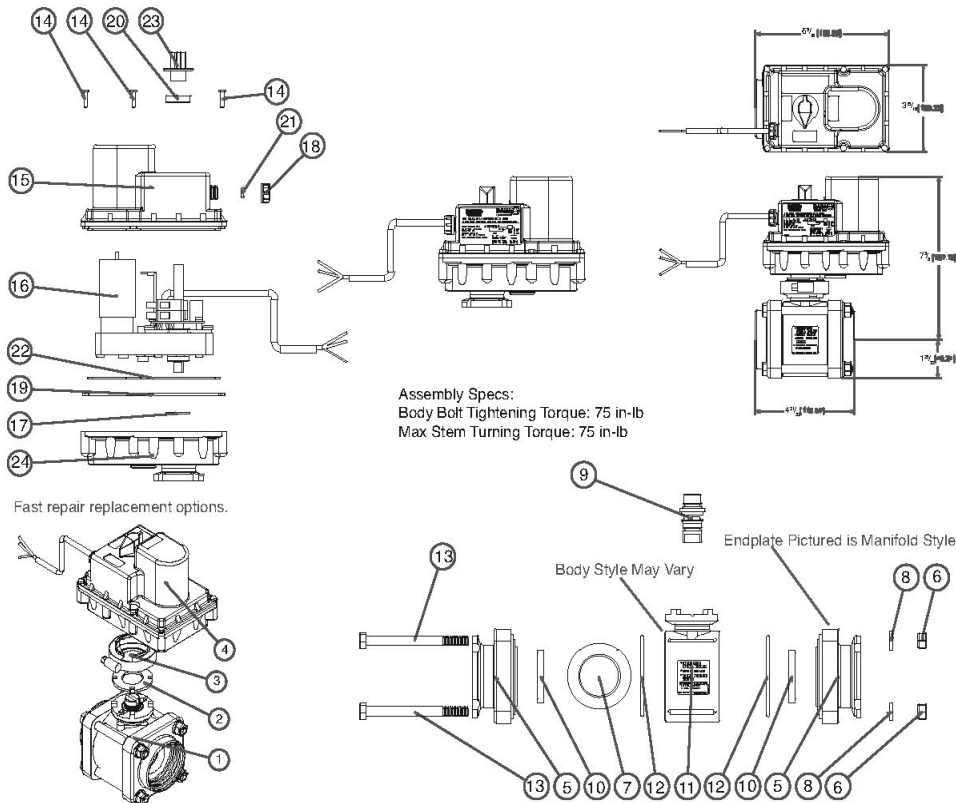

REPLACEMENT PARTS MEV100BLCF - MEV200BLCF - MEV220BLCF			
ITEM	PART NO.	DESCRIPTION	QTY.
1	MEV100BLXR1	1" FP Electric Valve Sub Assembly	1
1	MEV200BLXR1	2" Electric Valve Sub Assembly	1
1	MEV220BLXR1	2" FP Electric Valve Sub Assembly	1
2	MVE004	Electric Valve Flange Gasket	1
3	FC100	1" Flange clamp	1
4	EV3100	1" 3/4 Second 3 Wire Motor Assembly	1
4	EV4100	2" 1 1/4 Second 3 Wire Motor Assembly	1
5	VE10278A	1" Manifold Endplate for EV	2
5	VE20294	2" Manifold Endplate for EV	2
5	VE25378A	2" FP Manifold Endplate for EV	2
6	V10119	5/16" Stainless Steel Body Nut (1")	4
6	V20019	3/8" Stainless Steel Body Nut (2")	4
7	VE10355	1" EV 316 Stainless Steel Hollow Ball	1
7	VE20355	2" EV 316 Stainless Steel Hollow Ball	1
7	VE25355	2" FPEV 316 Stainless Steel Hollow Ball	1
8	V10118	5/16" Stainless Steel Lock Washer (1")	4
8	V20018	3/8" Stainless Steel Lock Washer (2")	4
9	MEV10151	1" Stainless Steel Stem w/Seals	1
9	MEV25151	2" Stainless Steel Stem w/Seals	1
10	VE10258A	1" Electric Ball Seat	2
10	VE20258	2" Electric Ball Seat	2
10	VE25258A	2 V FP Electric Ball Seat	2
11	MEV10354AB	EV Body 1"	1
11	MEV20354AB	EV Body 2"	1
11	MEV25354AB	EV Body 2" FP	1

REPLACEMENT PARTS MEV100BLCF - MEV200BLCF - MEV220BLCF			
ITEM	PART NO.	DESCRIPTION	QTY.
12	VE10264	1" EV Body FKM O-Ring	2
12	VE20264	2" EV Body FKM O-Ring	2
12	V25264	2" FP EV Body FKM O-Ring	2
13	V10117	5/16" X 3 1/2" SS Body Bolt	4
13	V20017	3/8" X 4" SS Body Bolt (2")	4
13	V25017	3/8" X 4 1/2" SS Body Bolt (2" FP)	4
14	VE15220	Housing Screw	6
15	MVE10102	EV Housing Top for Small Motor (1")	1
15	MVE25102	EV Housing Top for Large Motor (2")	1
16	VE4984	3/4 Sec 3 Wire On/Of Motor Assy (1")	1
16	VE4987	1 1/4 Second On/Off Motor (2")	1
17	MVE107	EV Motor Shaft Gasket 1/2" ID	1
18	MVE002	Heyco 1/4" Threaded Bushing	1
19	MVE104	Outer EV Housing Gasket	1
20	VE109E	Indicator Seal	1
21	MVE007	3mm X 5mm FKM O-Ring	1
22	MVE106	Inner EV Housing Gasket	1
23	VE107A	EV Flow Indicator	1
24	MEV10101	1" EV Housing Bottom - Large Motor	1
24	MEV25101	2" EV Housing Bottom - Large Motor	1
25	EV10210	1" Repair Kit (Includes Parts 2, 9, 10, 12)	1
25	EV20210	2 V Repair Kit (Includes Parts 2, 9, 10, 12)	1
25	EV25210	2" FP Repair Kit (Includes Parts 2, 9, 10, 12)	1

The Spray Tech part number can be derived by adding the prefix 'TE' to the listed Banjo part numbers.



Manifold Bolted Ball Valves 4 and 6 Bolt Valves

FEATURES

- FKM (viton type) seals.
- PTFE self-lubricating stem bushings and seats cannot stick or bind.
- Precision molded in polypropylene. Polypropylene is reinforced with fiberglass for additional strength.
- Self-aligning ball moves freely against the PTFE seats for smooth operation. The valve opens and closes with very little pressure on the handle.
- Ball is diamond turned, after molding, to make it spherically perfect, which provides precise contact between ball and seats.



4 AND 6 BOLT VALVES

PART NO.	DESCRIPTION	MAX PSI	PIPE SIZE	OPENING THRU BALL	QUANTITY
MV100CF	1" X 1" Flange Ball Valve	150	1"	1"	24/per box
MV200CF	2" X 2" Flange Ball Valve	150	2"	1 1/2"	12/per box
MV220CF	2" X 2" FP Flange Ball Valve	150	2"	2"	8/per box
MV300	3" X 3" Standard Port Ball Valve	100	3"	2 1/2"	6/per box
MV300CF	3" X 3" Full Port Ball Valve	100	3"	3"	6/per box

CHART 1

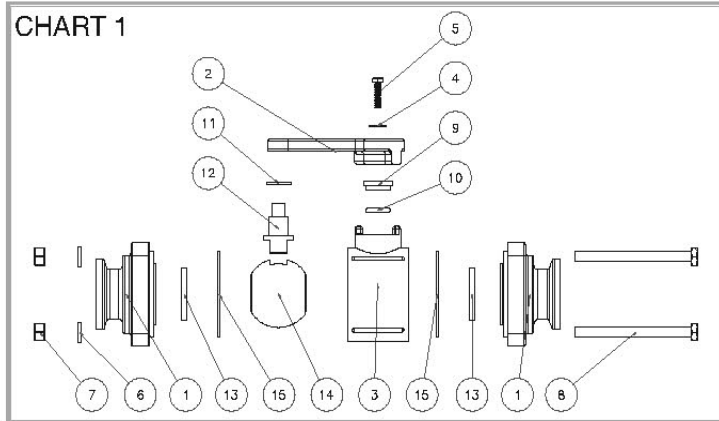

*Valve Repair Kits Contain Items Marked With Asterisk
 1 Ball 2 Body O-Rings 1 Thrust Washer
 2 Ball Seats 1 Upper Stem Bushing 1 Stem O-Ring

CHART 2

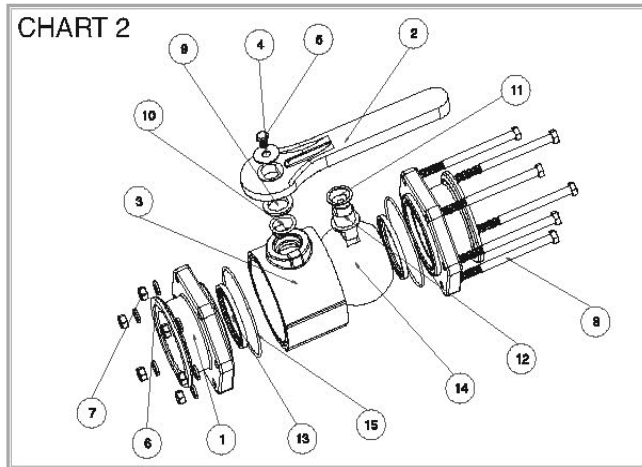

The Spray Tech part number can be derived by adding the prefix 'TE' to the listed Banjo part numbers.



REPLACEMENT PARTS - MV100CF -CHART 1				
ITEM	PART NO.	DESCRIPTION	QTY.	
1	V10278	1" Manifold Endplate	2	
2	V10153A	Handle	1	
3	V10254	Valve Body	1	
4	V07021A	S.S. Handle Washer	1	
5	V10021A	#10 x 3/4" S.S. Handle Bolt	1	
6	V10118	5/16" S.S. Lock Washer	4	
7	V10119	5/16" S.S. Nut	4	
8	V10117	5/16" x 3 1/2" S.S. Body Bolt	4	
9	V10159*	Upper Stem Bushing	1	
10	V10163*	Stem O Ring FKM (viton type)	1	
11	V10060*	Thrust Washer	1	
12	V10151A	Stem	1	
13	V10258A*	Ball Seat	2	
14	V10155*	Valve Ball	1	
15	V10264	Valve Body O Ring FKM (viton type)	2	
N/S	V10200	Valve Repair Kit	N/S	

REPLACEMENT PARTS - MV300 -CHART 2				
ITEM	PART NO.	DESCRIPTION	QTY.	
1	MV30264	3" FP Manifold Endplate	2	
2	V25153	Handle	1	
3	V30254	Valve Body	1	
4	V25121	S.S. Handle Washer	1	
5	V25020	3/8" x 1/2" S.S. Handle Bolt	1	
6	V20018	3/8" S.S. Lock Washer	6	
7	V20019	3/8" S.S. Nut	6	
8	V30017	3/8" x 5" S.S. Body Bolt	6	
9	V25160*	Upper Stem Bushing	1	
10	V25163*	Stem O Ring FKM (viton type)	1	
11	V25060*	Thrust Washer	1	
12	V25151B	Stem	1	
13	V30258A*	Ball Seat	2	
14	V30255*	Valve Ball	1	
15	V30265*	Valve Body O Ring FKM (viton type)	2	
N/S	V30200	Valve Repair Kit	N/S	

REPLACEMENT PARTS - MV200CF -CHART 1				
ITEM	PART NO.	DESCRIPTION	QTY.	
1	V20294	2" Manifold Endplate	2	
2	V20153	Handle	1	
3	V20254	Valve Body	1	
4	V20021	S.S. Handle Washer	1	
5	V20020	1/4" x 1/2" S.S. Handle Bolt	1	
6	V20018	3/8" S.S. Lock Washer	4	
7	V20019	3/8" S.S. Nut	4	
8	V20017	3/8" x 4 1/2" S.S. Body Bolt	4	
9	V20159*	Upper Stem Bushing	1	
10	V20163*	Stem O Ring FKM (viton type)	1	
11	V20060*	Thrust Washer	1	
12	V20151M	Stem	1	
13	V20258A*	Ball Seat	2	
14	V20255A*	Valve Ball	1	
15	V20264*	Valve Body O Ring FKM (viton type)	2	
N/S	V20200	Valve Repair Kit	N/S	

REPLACEMENT PARTS - MV300CF-CHART 2				
ITEM	PART NO.	DESCRIPTION	QTY.	
1	V35278	3" FP Manifold Endplate	2	
2	V25153	Handle	1	
3	V35254	Valve Body	1	
4	V25121	S.S. Handle Washer	1	
5	V25020	3/8" x 1/2" S.S. Handle Bolt	1	
6	V20018	3/8" S.S. Lock Washer	6	
7	V20019	3/8" S.S. Nut	6	
8	V35017	3/8" x 6" S.S. Body Bolt	6	
9	V25160*	Upper Stem Bushing	1	
10	V25163*	Stem O Ring FKM (viton type)	1	
11	V25060*	Thrust Washer	1	
12	V25151B	Stem	1	
13	V35258A*	Ball Seat	2	
14	V35255A*	Valve Ball	1	
15	V35265*	Valve Body O Ring FKM (viton type)	2	
N/S	V35200	Valve Repair Kit	1	

REPLACEMENT PARTS - MV220CF CHART 1				
ITEM	PART NO.	DESCRIPTION	QTY.	
1	V25478	2" FP Manifold Endplate	2	
2	V25153	Handle	1	
3	V25254	Valve Body	1	
4	V25121	S.S. Handle Washer	1	
5	V25020	3/8" x 1/2" S.S. Handle Bolt	1	
6	V20018	3/8" S.S. Lock Washer	4	
7	V20019	3/8" S.S. Nut	4	
8	V20017	3/8" x 4" S.S. Body Bolt	4	
9	V25160*	Upper Stem Bushing	1	
10	V25163*	Stem O Ring FKM (viton type)	1	
11	V25060*	Thrust Washer	1	
12	V25151B	Stem	1	
13	V25258A*	Ball Seat	2	
14	V25255A*	Valve Ball	1	
15	V25264*	Valve Body O Ring FKM (viton type)	2	
N/S	V25200	Valve Repair Kit	N/S	



The Spray Tech part number can be derived by adding the prefix 'TE' to the listed Banjo part numbers.



Manifold Valves

PATENTED

“Manifold Stubby Valve”

FEATURES

- Stainless steel bolts.
- Glass filled polypropylene.
- Multiple design options.
- Unique patented compact design.
- Lightweight.
- Maximum operating pressure 100 P.S.I. @ 70°F. 75 P.S.I. @ 150°F.

2" Standard Port



VSM200CF



VSF200CF

PART NO.	DESCRIPTION	MAX PSI	PIPE SIZE	OPENING THRU BALL	QUANTITY
VSM200CF	2" SP Flange X 2" Male NPT	100	2"	1½"	24/per box
VSF200CF	2" SP Flange X 2" Male Adapter	100	2"	1½"	24/per box

2" Full Port



MVS220FP



MVSF220FP



MVS220CF

PART NO.	DESCRIPTION	MAX PSI	PIPE SIZE	OPENING THRU BALL	QUANTITY
MVS220FP	2" FP Flange X 2" Female NPT	100	2"	2"	8/per box
MVSF220FP	2" FP Flange X 2" Male Adapter	100	2"	2"	8/per box
MVS220CF	2" FP Flange X 2" FP Flange	100	2"	2"	8/per box

3" Standard Port



MVSF300



MVSMT300

PART NO.	DESCRIPTION	MAX PSI	PIPE SIZE	OPENING THRU BALL	QUANTITY
MVSF300	3" Manifold Flange X 3" Male Adapter	100	3"	2½"	6/per box
MVSMT300	3" Manifold Flange X 3" Male NPT	100	3"	2½"	6/per box

NOTE: Replacement Parts for MVSF300 and MVSMT300 on Page 95.



The Spray Tech part number can be derived by adding the prefix 'TE' to the listed Banjo part numbers.



NOTE:
End Plates and body style may vary from picture.

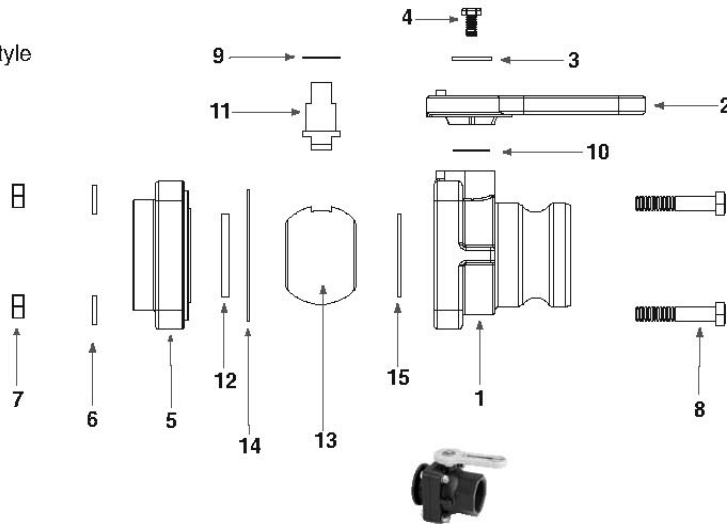

REPLACEMENT PARTS -VSMT200CF - VSF200CF - MVSF220FP - MVSF220FP - MVS220CF				
ITEM	PART NO.	DESCRIPTION	QTY.	
3	V20021	Handle Washer	1	
4	V20020	Handle Bolt	1	
6	V20018	Lock Washer	4	
7	V20019	Body Nut	4	
8	V20010SS	Body Bolt	4	
9	V20060*	Upper Stem Bushing	1	
10	V20060*	Thrust Bearing	1	
11	VS20151	Stem	1	

REPLACEMENT PARTS - MVS220FP				
ITEM	PART NO.	DESCRIPTION	QTY.	
1	VFT25254	2" FP Stubby Female NPT Body	1	
2	VS25153	2" FP Stubby Handle	1	
5	VS25378	2" Stubby End Plate	1	
12	VS25258AR1	Seat	2	
13	VS25255*	Ball	1	
14	V25214V*	Body Gasket FKM (viton type)	1	

Valve Repair Kits Contain Items Marked With Asterisk



REPLACEMENT PARTS - VSMT200CF				
ITEM	PART NO.	DESCRIPTION	QTY.	
1	VMT22254	2" Male NPT Style Body	1	
2	VS20152SH	2" Short Style Handle	1	
5	VS20294	2" Stubby End Plate	1	
12	VS20258A*	Seat	2	
13	VS20255*	Ball	1	
14	V21204*	Body Gasket	1	
N/S	VS20200*	Repair Kit	1	



REPLACEMENT PARTS - MVSF220FP				
ITEM	PART NO.	DESCRIPTION	QTY.	
1	VF25254	2" FP Stubby Body Male Adapter	1	
2	VS25153	2" FP Stubby Handle	1	
5	VS25378	2" Stubby End Plate	1	
12	VS25258AR1	Seat	2	
13	VS25255*	Ball	1	
14	V25214*	Body Gasket	1	



REPLACEMENT PARTS - VSF200CF				
ITEM	PART NO.	DESCRIPTION	QTY.	
1	VF22254	2" Male Quick Connect Style Body	1	
2	VS20152SH	2" Short Style Handle	1	
5	VS20294	2" Stubby End Plate	1	
12	VS20258A*	Seat	2	
13	VS20255*	Ball	1	
14	V21204*	Body Gasket	1	
N/S	VS20200*	Repair Kit	1	



REPLACEMENT PARTS - MVS220CF				
ITEM	PART NO.	DESCRIPTION	QTY.	
1	MV25254	2" Full Port Manifold Body	1	
2	VS25153	2" Full Port Stubby Handle	1	
5	VS25378	2" Stubby End Plate	1	
12	VS25258AR1	Seat	2	
13	VS25255	Ball	1	
14	V25214V	Body Gasket FKM (viton type)	1	

The Spray Tech part number can be derived by adding the prefix 'TE' to the listed Banjo part numbers.



3-Way Manifold Ball Valves

FEATURES

- Stainless Steel Bolts.
- Precision molded in polypropylene. Polypropylene is reinforced with fiberglass for additional strength.
- Self-aligning ball moves freely against the PTFE seats for smooth operation. The valve opens and closes with very little pressure on the handle.
- Ball is diamond turned, after molding, to make it spherically perfect, which provides precise contact between ball and seats.
- FKM (viton type) seals.
- PTFE self-lubricating stem bushings and seats cannot stick or bind.
- Maximum operating pressure 100 P.S.I.



MV100BL



MV100SL

4 BOLT BOTTOM LOAD MANIFOLD VALVES

PART NO.	DESCRIPTION	MAX PSI	FLANGE SIZE	OPENING THRU BALL	QUANTITY PER BOX	HANDLE TYPE
MV100BL	1" Flanges	100	1"	1"	18/Per Box	T
MV200BL	2" Standard Port Flanges	100	2" SP	1 1/2"	12/Per Box	T
MV220BL	2" Full Port Flanges	100	2" FP	2"	8/Per Box	Straight

BOTTOM LOAD: Directional flow right or left. Valve can be turned off to stop flow.

4 BOLT SIDE LOAD MANIFOLD VALVES

PART NO.	DESCRIPTION	MAX PSI	FLANGE SIZE	OPENING THRU BALL	QUANTITY PER BOX	HANDLE TYPE
MV100SL	1" Flanges	100	1"	1"	18/Per Box	T
MV200SL	2" Standard Port Flanges	100	2" SP	1 1/2"	10/Per Box	Straight
MV220SL	2" Full Port Flanges	100	2" FP	2"	8/Per Box	Straight
MVT220SL	2" FP Flanges (NonStock)	100	2" FP	2"	8/Per Box	T

SIDE LOAD: Directional flow right or left. Valve cannot be turned off.

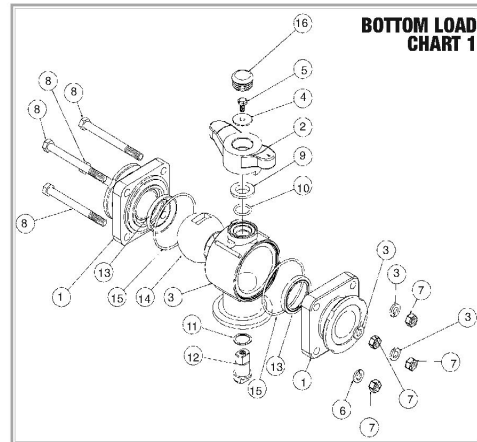

**BOTTOM LOAD
CHART 1**

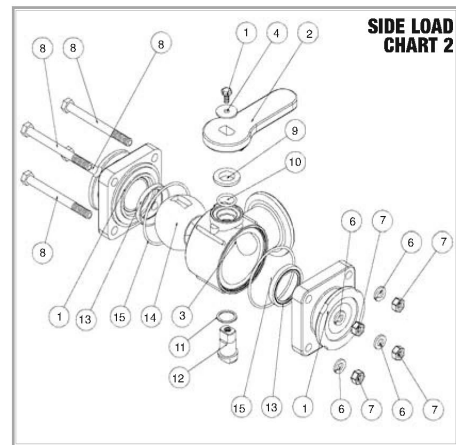

**SIDE LOAD
CHART 2**



MV300BL

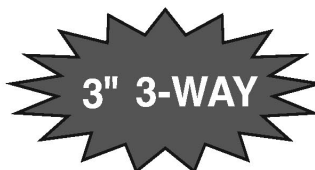

3" 6 BOLT BOTTOM LOAD MANIFOLD VALVES

PART NO.	DESCRIPTION	MAX PSI	FLANGE SIZE	OPENING THRU BALL	QUANTITY PER BOX	HANDLE TYPE
MV300BL	3" Flanges	100	3"	3"	6/Per Box	Straight

REPLACEMENT PARTS – MV300BL

ITEM	PART NO.	DESCRIPTION	QTY.
1	MV35278	3" Manifold End Plate	2
2	V25353B	Handle (Straight)	1
3	MV35254BL	3" FP Manifold Body	1
4	V25121	Handle Washer	1
5	V25020	Handle Bolt	1
6	V20018	Lockwasher	4
7	V20019	Body Nut	4
8	V25017	Body Bolt	4
9	V25160	Upper Stem Bushing	1
10	V25163	Stem O-Ring –FKM(viton type)	1
11	V25060	Thrust Bushing	1
12	V25151B	Stem	1
13	V35258A	Seat	2
14	V35255BL	Bottom Load Ball	1
15	V35264BL	Body O-Ring	2



The Spray Tech part number can be derived by adding the prefix 'TE' to the listed Banjo part numbers.



BOTTOM LOAD - Chart 1

REPLACEMENT PARTS – MV100BL				
ITEM	PART NO.	DESCRIPTION	QTY.	
1	VE10278	1" Manifold End Plate	2	
2	V10353TB	Handle (T)	1	
3	MV10354B	1" Manifold Body	1	
4	V07021A	Handle Washer	1	
5	V10020A	Handle Bolt	1	
6	V10118	Lockwasher	4	
7	V10119	Body Nut	4	
8	V10117	Body Bolt	4	
9	V10159	Upper Stem Bushing	1	
10	V10163	Stem O-Ring – FKM (viton type)	1	
11	V10060	Thrust Bushing	2	
12	V10151A	Stem	1	
13	VE10258A	Seat	2	
14	V10355B	Bottom Load Ball	1	
15	VE10264	Body O-Ring	2	
16	V20353C	Handle Cap	1	

SIDE LOAD - Chart 2

REPLACEMENT PARTS – MV100SL				
ITEM	PART NO.	DESCRIPTION	QTY.	
1	VE10278	1" Manifold End Plate	2	
2	V10353TS	Handle (T)	1	
3	MV10354S	1" Manifold Body	1	
4	V07021A	Handle Washer	1	
5	V10020A	Handle Bolt	1	
6	V10118	Lockwasher	4	
7	V10119	Body Nut	4	
8	V10117	Body Bolt	4	
9	V10159	Upper Stem Bushing	1	
10	V10163	Stem O-Ring – FKM (viton type)	1	
11	V10060	Thrust Bushing	1	
12	V10151A	Stem	1	
13	VE10258A	Seat	2	
14	V10355S	Side Load Ball	1	
15	VE10264	Body O-Ring	2	
16	V20353C	Handle Cap	1	

REPLACEMENT PARTS – MV200BL				
ITEM	PART NO.	DESCRIPTION	QTY.	
1	V20394	2" Manifold End Plate	2	
2	V20353TB	Handle (T)	1	
3	MV20354B	2" Manifold Body	1	
4	V20021	Handle Washer	1	
5	V20020	Handle Bolt	1	
6	V20018	Lockwasher	4	
7	V20019	Body Nut	4	
8	V20017	Body Bolt	4	
9	V20159	Upper Stem Bushing	1	
10	V20163	Stem O-Ring – FKM (viton type)	1	
11	V20060	Thrust Bushing	1	
12	V20151M	Stem	1	
13	VE20258A	Seat	2	
14	V20355B	Bottom Load Ball	1	
15	VE20264	Body O-Ring	2	
16	V20353C	Handle Cap	1	



REPLACEMENT PARTS – MV200SL				
ITEM	PART NO.	DESCRIPTION	QTY.	
1	V20394	2" Manifold End Plate	2	
2	V20153SH	Handle (Straight)	1	
3	MV20354S	2" Manifold Body	1	
4	V20021	Handle Washer	1	
5	V20020	Handle Bolt	1	
6	V20018	Lockwasher	4	
7	V20019	Body Nut	4	
8	V20017	Body Bolt	4	
9	V20159	Upper Stem Bushing	1	
10	V20163	Stem O-Ring – FKM (viton type)	1	
11	V20060	Thrust Bushing	1	
12	V20151M	Stem	1	
13	VE20258A	Seat	2	
14	V20355S	Side Load Ball	1	
15	VE20264	Body O-Ring	2	

REPLACEMENT PARTS – MV220BL				
ITEM	PART NO.	DESCRIPTION	QTY.	
1	V25378	2" Manifold End Plate	2	
2	V25353B	Handle (Straight)	1	
2	V25353TB	Handle (T)	1	
3	MV25354B	2" FP Manifold Body	1	
4	V25121	Handle Washer	1	
5	V25020	Handle Bolt	1	
6	V20018	Lockwasher	4	
7	V20019	Body Nut	4	
8	V25017	Body Bolt	4	
9	V25160	Upper Stem Bushing	1	
10	V25163	Stem O-Ring – FKM (viton type)	1	
11	V25060	Thrust Bushing	1	
12	V25151B	Stem	1	
13	V25258	Seat	2	
14	V25355B	Bottom Load Ball	1	
15	V25264	Body O-Ring	2	





REPLACEMENT PARTS – MV220SL				
ITEM	PART NO.	DESCRIPTION	QTY.	
1	V25378	2" Manifold End Plate	2	
2	V25153SH	Handle (Straight)	1	
2	V25353TS	Handle (T) (MVT220SL only)	1	
3	MV25354S	2" FP Manifold Body	1	
4	V25121	Handle Washer	1	
5	V25020	Handle Bolt	1	
6	V20018	Lockwasher	4	
7	V20019	Body Nut	4	
8	V25017	Body Bolt	4	
9	V25160	Upper Stem Bushing	1	
10	V25163	Stem O-Ring – FKM (viton type)	1	
11	V25060	Thrust Bushing	1	
12	V25151B	Stem	1	
13	V25258	Seat	2	
14	V25355S	Side Load Ball	1	
15	V25264	Body O-Ring	2	

The Spray Tech part number can be derived by adding the prefix 'TE' to the listed Banjo part numbers.

Standard Manual Valves

Standard Manual Valves		
Brass Gate Valves Standard Port 	Part No.	Description
	MV025	1/4" Gate Valve
	MV038	3/8" Gate Valve
	MV050	1/2" Gate Valve
	MV075	3/4" Gate Valve
	MV100	1" Gate Valve
	MV125	1 1/4" Gate Valve
	MV150	1 1/2" Gate Valve
	MV200	2" Gate Valve
	MV300	3" Gate Valve
MV400	4" Gate Valve	
Ball Valves Standard Port 	Part No.	Description
	MV025B	1/4" Brass Ball Valve
	MV025BSS	1/4" Stainless Steel Ball Valve
	MV90FFB14	1/4" Chromed Brass Ball Valve
	HY1514	1/4" Poly Ball Valve
	MV038B	3/8" Brass Ball Valve
	MV038BSS	3/8" Stainless Steel Ball Valve
	MV050B	1/2" Brass Ball Valve
	MV050BSS	1/2" Stainless Steel Ball Valve
	MV90FMB12	1/2" Female x 1/2" Male Chromed Brass Ball Valve
	MV075B	3/4" Brass Ball Valve
	MV075BSS	3/4" Stainless Steel Ball Valve
	MV100B	1" Brass Ball Valve
	MV100BSS	1" Stainless Steel Ball Valve
	MV125B	1 1/4" Brass Ball Valve
	MV125BSS	1 1/4" Stainless Steel Ball Valve
	MV150B	1 1/2" Brass Ball Valve
	MV150BSS	1 1/2" Stainless Steel Ball Valve
	MV200B	2" Brass Ball Valve
	MV200BSS	2" Stainless Steel Ball Valve
MV300B	3" Brass Ball Valve	
Check Valves	Part No.	Description
	MV050CV	1/2" Poly Check Valve
	MV075CV	3/4" Poly Check Valve
	MV100CV	1" Poly Check Valve
	MV125CV	1 1/4" Poly Check Valve
	MV150CV	1 1/2" Poly Check Valve
	MV200CV	2" Poly Check Valve
	MV300CVB	3" Brass Check Valve
Garden Hose Shut-off Y Valve	HYLA23	3/4" fght inlet, 3/4" mght outlets

PIPE FITTINGS

		Part Numbers by Material						
 Nipples (mpt x mpt)	Size	Std Poly	Std Poly Bag Qty	Banjo Poly 6" max length	Banjo Poly Bag Qty	Galvanized Steel	Stainless Steel	Other Metal +Use AL for Alumi- num, BR for Brass, B for Black Iron
	● Desired Length in Inches. Use '0' for close nipples. Some lengths AND some materials unavailable.	1/8" 1/4" 3/8" 1/2" 3/4" 1" 1 1/4" 1 1/2" 2" 3" 4"	TCN018X0 TCN014X0 TCN038X0 TCN012X0 TCN034X0 TCN100X0 TCN114X0 TCN112X0 TCN200X0 - -	25 25 25 25 25 25 - - - - -	- TEN025X0 TEN038X0 TEN050X● TEN075X● TEN100X● TEN125X● TEN150X● TEN200X● TEN300X● TEN400X0	- 10 10 10 10 10 10 10 - - -	ALN018X● ALN025X● ALN038X● ALN050X● ALN075X● ALN100X● ALN125X● ALN150X● ALN200X● ALN300X● ALN400X●	ALN018X●SS ALN025X●SS ALN038X●SS ALN050X●SS ALN075X●SS ALN100X●SS ALN125X●SS ALN150X●SS ALN200X●SS ALN300X●SS ALN400X●SS
 Reducing Nipples (mpt x mpt)	1/4" x 1/8" 3/8" x 1/8" 3/8" x 1/4" 1/2" x 1/8" 1/2" x 1/4" 1/2" x 3/8" 3/4" x 3/8" 3/4" x 1/2" 1" x 1/2" 1" x 3/4" 1 1/4" x 3/4" 1 1/4" x 1" 1 1/2" x 1" 1 1/2" x 1 1/4" 2" x 1 1/4" 2" x 1 1/2" 3" x 2"	TCN014018 TCN038018 TCN038014 TCN012018 TCN012014 TCN012038 TCN034038 TCN034012 - - - - - - - - - -	25 25 25 25 25 25 25 25 - - - - - - - - - -	- - - - - TEN050038 - TEN075050 TEN100050 TEN100075 TEN125075 TEN125100 TEN150100 TEN150125 TEN200125 TEN200150 TEN300200	- - - - - 10 - 10 10 10 10 10 10 10 10 10 10 -	- - - - - - - - - - - - - - - -	- - - - - - - - - - - - - - - -	
 Caps (fpt)	1/8" 1/4" 3/8" 1/2" 3/4" 1" 1 1/4" 1 1/2" 2" 3"	- - - - TCN3500 - - - - -	- - - - 25 - - - - -	- - - - - TECAP050 TECAP075 TECAP100 TECAP125 TECAP150 TECAP200 TECAP300	- - - 10 10 10 10 10 10 10 10 -	ALCAP018 ALCAP025 ALCAP038 ALCAP050 ALCAP075 ALCAP100 ALCAP125 ALCAP150 ALCAP200 ALCAP300	ALCAP018SS ALCAP025SS ALCAP038SS ALCAP050SS ALCAP075SS ALCAP100SS ALCAP125SS ALCAP150SS ALCAP200SS ALCAP300SS	- - - - - - - - - -
 Plugs (mpt)	1/8" 1/4" 3/8" 1/2" 3/4" 1" 1 1/4" 1 1/2" 2" 3"	TCF018 TCF014 TCF038 TCF012 TCF034 TCF100 TCF114 TCF112 TCF200 -	25 25 25 25 25 25 - - - -	- - - - - - - - - -	- - - 10 10 10 10 10 10 10 10	ALPUG018 ALPUG025 ALPUG038 ALPUG050 ALPUG075 ALPUG100 ALPUG125 ALPUG150 ALPUG200 ALPUG300	ALPUG018SS ALPUG025SS ALPUG038SS ALPUG050SS ALPUG075SS ALPUG100SS ALPUG125SS ALPUG150SS ALPUG200SS ALPUG300SS	ALPUG018BR ALPUG025BR - ALPUG050BR - - - - - -
 Couplers (fpt x fpt)	1/8" 1/4" 3/8" 1/2" 3/4" 1" 1 1/4" 1 1/2" 2" 3" 4"	TCCUP018 TCCUP014 TCCUP038 TCCUP012 TCCUP034 TCCUP100 TCCUP114 TCCUP112 TCCUP200 - -	- - - 25 25 25 - - - - -	- - - - - - - - - -	- - - 10 10 10 10 10 10 10 10	ALCUP018 ALCUP025 ALCUP038 ALCUP050 ALCUP075 ALCUP100 ALCUP125 ALCUP150 ALCUP200 ALCUP300 ALCUP400	ALCUP018SS ALCUP025SS ALCUP038SS ALCUP050SS ALCUP075SS ALCUP100SS ALCUP125SS ALCUP150SS ALCUP200SS ALCUP300SS ALCUP400SS	- ALCUP025B - - - - - - ALCUP200B ALCUP300+ -





PIPE FITTINGS

Part Numbers by Material





Size	Part Numbers by Material							
	Std Poly	Std Poly Bag Qty	Banjo Poly	Banjo Poly Bag Qty	Galvanized Steel	Stainless Steel	Other Metal +Use AL for Aluminum, BR for Brass, B for Black Iron	
 <p>Reducing Couplers (Bell Reducers) (fpt x fpt)</p>	1/4" x 1/8"	-	-	-	-	ALR025018	ALR025018S	-
	3/8" x 1/8"	-	-	-	-	-	-	-
	3/8" x 1/4"	-	-	-	-	ALR038025	ALR038025S	-
	1/2" x 1/8"	-	-	-	-	ALR050018	ALR050018S	-
	1/2" x 1/4"	-	-	-	-	ALR050025	ALR050025S	-
	1/2" x 3/8"	-	-	-	-	ALR050038	ALR050038S	-
	3/4" x 1/8"	-	-	-	-	ALR075018	ALR075018S	-
	3/4" x 1/4"	-	-	-	-	ALR075025	ALR075025S	-
	3/4" x 3/8"	-	-	-	-	ALR075038	ALR075038S	-
	3/4" x 1/2"	-	-	-	-	ALR075050	ALR075050S	-
	1" x 3/8"	-	-	-	-	ALR100038	ALR100038S	-
	1" x 1/2"	-	-	-	-	ALR100050	ALR100050S	-
	1" x 3/4"	-	-	-	-	ALR100075	ALR100075S	-
	1 1/4" x 1/2"	-	-	TERC100075	10	ALR125050	ALR125050S	-
	1 1/4" x 3/4"	-	-	-	-	ALR125075	ALR125075S	-
	1 1/4" x 1"	-	-	-	-	ALR125100	ALR125100S	-
	1 1/2" x 1/2"	-	-	-	-	ALR150050	ALR150050S	-
	1 1/2" x 3/4"	-	-	-	-	ALR150075	ALR150075S	-
	1 1/2" x 1"	-	-	TERC150100	10	ALR150100	ALR150100S	-
	1 1/2" x 1 1/4"	-	-	TERC150125	10	ALR150125	ALR150125S	-
	2" x 1/2"	-	-	TERC200050	10	-	-	-
	2" x 1"	-	-	TERC200100	10	ALR200100	ALR200100S	-
	2" x 1 1/4"	-	-	TERC200125	10	ALR200125	ALR200125S	-
	2" x 1 1/2"	-	-	TERC200150	10	ALR200150	ALR200150S	-
	2 1/2" x 2"	-	-	-	-	ALR250200	ALR250200S	-
	3" x 2"	-	-	TERC300200	-	ALR300200	ALR300200S	ALR300200B
	4" x 2"	-	-	-	-	ALR400200	ALR400200S	-
	4" x 3"	-	-	-	-	ALR400300	ALR400300S	-

 <p>Reducing Bushings (mpt x fpt)</p>	1/4" x 1/8"	TCRB1418	-	-	-	ALB025018	ALB025018S	ALB025018 BR
	3/8" x 1/8"	TCRB3818	25	-	-	-	-	-
	3/8" x 1/4"	TCRB3814	25	TERB038025	10	ALB038025	ALB038025S	-
	1/2" x 1/8"	TCRB1218	25	-	-	ALB050018	ALB050018S	-
	1/2" x 1/4"	TCRB1214	25	TERB050025	10	ALB050025	ALB050025S	-
	1/2" x 3/8"	TCRB1238	25	TERB050038	10	ALB050038	ALB050038S	-
	3/4" x 1/8"	TCRB3418	25	TERB075018	10	ALB075018	ALB075018S	-
	3/4" x 1/4"	TCRB3414	25	TERB075025	10	ALB075025	ALB075025S	ALB075025B
	3/4" x 3/8"	TCRB3438	25	TERB075038	10	ALB075038	ALB075038S	ALB075038B
	3/4" x 1/2"	TCRB3412	25	TERB075050	10	ALB075050	ALB075050S	ALB075050B
	1" x 1/8"	-	-	TERB100018	10	-	-	-
	1" x 1/4"	-	-	TERB100025	10	ALB100025	ALB100025S	-
	1" x 3/8"	-	-	-	-	ALB100038	ALB100038S	ALB100038B
	1" x 1/2"	TCRB1012	25	TERB100050	10	ALB100050	ALB100050S	-
	1" x 3/4"	TCRB1034	25	TERB100075	10	ALB100075	ALB100075S	-
	1 1/4" x 1/4"	-	-	-	-	ALB125025	ALB125025S	-
	1 1/4" x 3/8"	-	-	TERB125038	10	ALB125038	ALB125038S	-
	1 1/4" x 1/2"	-	-	-	-	ALB125050	ALB125050S	-
	1 1/4" x 3/4"	TCRB11434	-	TERB125075	10	ALB125075	ALB125075S	-
	1 1/4" x 1"	TCRB1141	-	TERB125100	10	ALB125100	ALB125100S	-
	1 1/2" x 1/4"	-	-	-	-	ALB150025	ALB150025S	-
	1 1/2" x 1/2"	-	-	-	-	ALB150050	ALB150050S	-
	1 1/2" x 3/4"	TCRB11234	-	TERB150075	10	ALB150075	ALB150075S	-
	1 1/2" x 1"	TCRB1121	-	TERB150100	10	ALB150100	ALB150100S	-
	1 1/2" x 1 1/4"	TCRB112114	-	TERB150125	10	ALB150125	ALB150125S	-
	2" x 1/2"	-	-	-	-	ALB200050	ALB200050S	-
	2" x 3/4"	TCRB20034	-	TERB200075	10	ALB200075	ALB200075S	-
	2" x 1"	TCRB200100	-	TERB200100	10	ALB200100	ALB200100S	-
	2" x 1 1/4"	TCRB200114	-	TERB200125	10	ALB200125	ALB200125S	-
	2" x 1 1/2"	TCRB200112	-	TERB200150	10	ALB200150	ALB200150S	-
	2 1/2" x 2"	TCRB212200	-	-	-	ALB250200	ALB250200S	-
	3" x 1 1/2"	-	-	TERB300150	-	-	-	-
	3" x 2"	TCRB300200	-	TERB300200	-	ALB300200	ALB300200S	ALB300200B
	4" x 2"	-	-	-	-	ALB400200	ALB400200S	ALB400200B
4" x 3"	-	-	TERB400300	-	ALB400300	ALB400300S	ALB400300B	
6" x 4"	-	-	-	-	-	-	ALB600400B	

PIPE FITTINGS



		Part Numbers by Material						
 Crosses (fpt)	Size	Std Poly	Std Poly Bag Qty	Banjo Poly	Banjo Poly Bag Qty	Galvanized Steel	Stainless Steel	Other Metal +Use AL for Aluminum, BR for Brass, B for Black Iron
		1/4"	-	-	-	-	ALCROS025	ALCROS025S
	3/8"	-	-	-	-	ALCROS038	ALCROS038S	-
	1/2"	-	-	TECROS050	5	ALCROS050	ALCROS050S	-
	3/4"	-	-	TECROS075	5	ALCROS075	ALCROS075S	-
	1"	-	-	TECROS100	5	ALCROS100	ALCROS100S	-
	1 1/4"	-	-	TECROS125	-	ALCROS125	ALCROS125S	-
	1 1/2"	-	-	TECROS150	-	ALCROS150	ALCROS150S	-
	2"	-	-	TECROS200	-	ALCROS200	ALCROS200S	-
	3"	-	-	-	-	ALCROS300	ALCROS300S	ALCROS300B
 Pipe Tees (fpt)	1/8"	-	-	-	-	-	-	-
	1/4"	TCTT14	25	-	-	ALT025	ALT025SS	ALT025+
	3/8"	TCTT38	-	TETT038	10	ALT038	ALT038SS	-
	1/2"	TCTT12	10	TETT050	10	ALT050	ALT050SS	ALT050B
	3/4"	TCTT34	10	TETT075	10	ALT075	ALT075SS	ALT075B
	1"	TCTT100	-	TETT100	10	ALT100	ALT100SS	ALT100B
	1 1/4"	TCTT114	-	TETT125	10	ALT125	ALT125SS	ALT125B
	1 1/2"	TCTT112	-	TETT150	-	ALT150	ALT150SS	-
	2"	TCTT200	-	TETT200	-	ALT200	ALT200SS	ALT200B
3"	-	-	TETT300	-	ALT300	ALT300SS	ALT300B	
Gauge Tees (fpt x 1/4" gauge port) *CY Gauge Tees include a mounting bracket.	1/2"	TCNT1214	25	-	-	CYMT12	-	-
	3/4"	TCNT3414	-	-	-	CYMT34	-	-
	1"	-	-	TETEG100	10	CYMT100	-	-
	1 1/4"	-	-	-	-	CYMT125	-	-
 Hose Barb Tees (sizes are double barb x single barb)	1/8"	-	-	-	-	-	-	-
	1/4"	TCT14	25	-	-	-	-	-
	3/8"	TCT38	25	-	-	-	-	-
	3/8" x 1/4"	TCT1438	25	-	-	-	-	-
	3/8" x 1/2"	TCT1238	25	-	-	-	-	-
	1/2"	TCT12	25	-	-	-	-	-
	1/2" x 1/4"	TCT1412	25	-	-	-	-	-
	1/2" x 3/8"	TCT3812	25	TEHBT050038	10	-	-	-
	1/2" x 3/4"	TCT3412	25	TEHBT050075	10	-	-	-
	5/8"	TCT58	25	-	-	-	-	-
	3/4"	TCT34	25	TEHBT075	10	-	-	-
	3/4" x 3/8"	TCT3834	25	-	-	-	-	-
	3/4" x 1/2"	TCT1234	25	TEHBT075050	10	-	-	-
	3/4" x 1"	-	-	TEHBT075100	10	-	-	-
	1"	TCT100	25	TEHBT100	10	-	-	-
	1" x 3/4"	-	-	TEHBT100075	10	-	-	-
	1 1/4"	TCT114	-	-	-	-	-	-
1 1/2"	TCT112	-	-	-	-	-	-	
2"	TCT200	-	-	-	-	-	-	
 Hose Barb Threaded Tees (sizes are double barb x male thread)	3/8" x 1/4"	TCT1438T	25	-	-	-	-	-
	3/8" x 1/2"	TCT1238T	25	-	-	-	-	-
	1/2"	TCT12T	25	-	-	-	-	-
	1/2" x 1/4"	TCT1412T	25	-	-	-	-	-
	1"	-	-	TEHTT100100	-	-	-	-
1 1/2" x 1"	-	-	TEHTT150100	-	-	-	-	
1 1/2" x 1 1/2"	-	-	TEHTT150150	-	-	-	-	
Hose Barb Female Threaded Tees (double barb x female thread)	3/4"	TCT34F	25	-	-	-	-	-

PIPE FITTINGS

Part Numbers by Material								
	Size	Std Poly	Std Poly Bag Qty	Banjo Poly	Banjo Poly Bag Qty	Galvanized Steel	Stainless Steel	Other Metal +Use AL for Aluminum, BR for Brass, B for Black Iron
 <p>Hose Menders (in hose menders, 'B' in the Other Metal category is for BRASS)</p>	1/8"	-	-	-	-	-	-	-
	3/16"	TCHM316	-	-	-	-	-	-
	1/4"	TCHM14	-	-	-	-	-	TCHM14B
	5/16"	TCHM516	-	-	-	-	-	-
	3/8"	TCHM38	-	-	-	-	-	TCHM38B
	1/2"	TCHM12	-	TEHM050	10	-	-	TCHM12B
	3/4"	TCHM34	-	TEHM075	10	-	-	TCHM34B
	1"	TCHM100	-	TEHM100	10	TCHM100S	-	-
	1 1/4"	TCHM114	-	TEHM125	10	TCHM125S	-	-
	1 1/2"	TCHM112	-	TEHM150	10	TCHM150S	-	-
	2"	TCHM200	-	TEHM200	10	TCHM200S	-	-
	3"	-	-	TEHM300	-	-	-	-
<p>Reducing Hose Menders</p>	3/8" x 1/4"	TCHM1438	25	-	-	-	-	-
	1/2" x 3/8"	TCHM1238	25	-	-	-	-	-
	5/8" x 3/8"	TCHM5838	25	-	-	-	-	-
	5/8" x 1/2"	TCHM1258	25	-	-	-	-	-
 <p>Hose Barb Elbows</p>	1/4"	TCHBEL14	25	-	-	-	-	-
	3/8"	TCHBEL38	25	-	-	-	-	-
	1/2"	TCHBEL12	25	-	-	-	-	-
	3/4"	TCHBEL34	25	-	-	-	-	-
	1"	TCHBEL100	25	TEHBEL100	10	-	-	-
	1 1/4"	TCHBEL114	-	-	-	-	-	-
	1 1/2"	TCHBEL112	-	-	-	-	-	-
2"	TCHBEL200	-	-	-	-	-	-	
<p>Reducing Hose Barb Elbows</p>	3/8" x 1/4"	TCHBEL3814	25	-	-	-	-	-
	1/2" x 1/4"	TCHBEL1214	25	-	-	-	-	-
	1/2" x 3/8"	TCHBEL1238	25	-	-	-	-	-
 <p>90° Elbows (fpt)</p>	1/8"	-	-	-	-	ALEL018	ALEL018SS	ALEL018B
	1/4"	TCNEL14	-	-	-	ALEL025	ALEL025SS	ALEL025+
	3/8"	TCNEL38	-	TEEL038	10	ALEL038	ALEL038SS	-
	1/2"	TCNEL12	25	TEEL050	10	ALEL050	ALEL050SS	-
	3/4"	TCNEL34	10	TEEL075	10	ALEL075	ALEL075SS	-
	1"	TCNEL100	-	TEEL100	10	ALEL100	ALEL100SS	-
	1 1/4"	TCNEL114	-	TEEL125	10	ALEL125	ALEL125SS	-
	1 1/2"	TCNEL112	-	TEEL150	10	ALEL150	ALEL150SS	-
	2"	TCNEL200	-	TEEL200	-	ALEL200	ALEL200SS	ALEL200B
	3"	-	-	TEEL300	-	ALEL300	ALEL300SS	ALEL300B
4"	-	-	-	-	-	-	ALEL400B	
 <p>45° Elbows (fpt)</p>	1/8"	-	-	-	-	-	-	-
	1/4"	-	-	-	-	ALEL45025	-	-
	3/8"	-	-	-	-	ALEL45038	-	-
	1/2"	-	-	-	-	ALEL45050	-	-
	3/4"	-	-	-	-	ALEL45075	-	-
	1"	-	-	TEEL45100	10	ALEL45100	-	-
	1 1/4"	-	-	-	-	ALEL45125	-	-
	1 1/2"	-	-	-	-	ALEL45150	-	-
	2"	-	-	-	-	ALEL45200	-	-
	3"	-	-	-	-	ALEL45300	-	-
4"	-	-	-	-	-	-	-	



PIPE FITTINGS

Part Numbers by Material

	Size	Std Poly	Std Poly Bag Qty	Banjo Poly	Banjo Poly Bag Qty	Galvanized Steel	Stainless Steel	Other Metal <small>+Use AL for Aluminum, BR for Brass, B for Black Iron</small>
 90° Street Elbows (mpt x fpt)	1/8"	-	-	-	-	ALSE018	ALSE018SS	ALSE018BR
	1/4"	TCSE14	25	-	-	ALSE025	ALSE025SS	ALSE025BR
	3/8"	TCSE38	-	TESE038	10	ALSE038	ALSE038SS	-
	1/2"	TCSE12	25	TESE050	10	ALSE050	ALSE050SS	ALSE050BR
	3/4"	TCSE34	25	TESE075	10	ALSE075	ALSE075SS	-
	1"	TCSE100	10	TESE100	10	ALSE100	ALSE100SS	-
	1 1/4"	TCSE114	-	TESE125	10	ALSE125	ALSE125SS	-
	1 1/2"	TCSE112	-	TESE150	10	ALSE150	ALSE150SS	ALSE150B
	2"	TCSE200	-	TESE200	-	ALSE200	ALSE200SS	ALSE200B
	3"	-	-	TESE300	-	ALSE300	ALSE300SS	ALSE300B
4"	-	-	-	-	ALSE400	-	-	
 45° Street Elbows (mpt x fpt)	1/8"	-	-	-	-	ALSE45018	-	-
	1/4"	TCSE4514	10	-	-	ALSE45025	-	-
	3/8"	-	-	-	-	ALSE45038	-	-
	1/2"	-	-	-	-	ALSE45050	-	-
	3/4"	TCSE4534	25	TESE45075	10	ALSE45075	-	-
	1"	-	-	TESE45100	10	ALSE45100	-	-
	1 1/4"	-	-	TESE45125	10	ALSE45125	-	-
	1 1/2"	-	-	TESE45150	10	ALSE45150	-	-
	2"	-	-	TESE45200	10	ALSE45200	-	-
	3"	-	-	TESE45300	-	ALSE45300	-	ALSE45300B
4"	-	-	-	-	-	-	-	
 Straight Hose Barbs (mpt x hose barb) <small>(in straight hose bars, 'B' in the Other Metal category is for BRASS - Part numbers containing 'K' are King Nipples)</small>	1/8" x 3/16"	TCA18316	25	-	-	(Plated Steel)	-	-
	1/8" x 1/4"	TCA1814	25	-	-		TC255	-
	1/8" x 5/16"	TCA18516	25	-	-	-	-	-
	1/8" x 3/8"	TCA1838	25	-	-	TC256	-	TC256B
	1/4" x 3/16"	TCA14316	25	-	-	-	-	-
	1/4"	TCA1414	25	TEHB025	10	TC250	TCA1414SS	TC250B
	1/4" x 5/16"	TCA14516	25	-	-	-	-	TC252B
	1/4" x 3/8"	TCA1438	25	TEHB025038	10	TC251	TCA1438SS	TC251B
	1/4" x 1/2"	TCA1412	25	TEHB025050	10	TC253	TCA1412SS	TC253B
	3/8" x 1/4"	TCA3814	25	-	-	TC240	TCA3814SS	TC240B
	3/8" x 5/16"	TCA38516	25	-	-	-	-	-
	3/8"	TCA3838	25	TEHB038	10	TC241	TCA3838SS	TC241B
	3/8" x 1/2"	TCA3812	25	TEHB038050	10	TC243	TCA3812SS	TC243B
	3/8" x 5/8"	TCA3858	25	-	-	-	-	-
	1/2" x 3/16"	TCA12316	25	-	-	-	-	-
	1/2" x 1/4"	TCA1214	25	-	-	TC230	TCA1214SS	TC230B
	1/2" x 3/8"	TCA1238	25	TEHB050038	10	TC231	-	TC231B
	1/2"	TCA1212	25	TEHB050	-	TC233/TC233K	TCA1212SS	TC233B
	1/2" x 5/8"	TCA1258	25	-	10		TC234	TCA1258SS
	1/2" x 3/4"	TCA1234	25	TEHB050075	10	TC235	TCA1234SS	TC235B
	1/2" x 1"	TCA1210	25	-	-	-	-	-
	3/4" x 1/4"	TCA3414	25	-	-	-	-	-
	3/4" x 3/8"	TCA3438	25	TEHB075038	10	TC221	-	TC221B
	3/4" x 1/2"	TCA3412	25	TEHB075050	10	TC223	TCA3412SS	TC223B
	3/4" x 5/8"	TCA3458	25	TEHB075058	10	TC224	-	TC224B
	3/4"	TCA3434	25	TEHB075	10	TC225/TC225K	TCA3434SS	TC225B
	3/4" x 1"	TCA3410	25	TEHB075100	10		TC227	TCA3410SS
	1" x 3/4"	TCA1034	25	TEHB100075	10	TC214/TC214K	TCA1034SS	TC214B
	1"	TCA1010	25	TEHB100	10		TC215K	TC215SS
	1" x 1 1/4"	TCA1114	25	TEHB100125	10	-	-	TC217B
1 1/4" x 3/4"	TCA11434	-	TEHB125075	10	-	-	-	
1 1/4" x 1"	TCA1141	-	TEHB125100	10	-	-	-	
1 1/4"	TCA1114	25	TEHB125	10	TC218	TC218SS	-	
1 1/4" x 1 1/2"	TCA114112	25	TEHB125150	10	-	-	-	
1 1/2" x 3/4"	TCA11234	25	-	-	-	-	-	
1 1/2" x 1"	TCA1121	25	TEHB150100	10	-	-	-	
1 1/2" x 1 1/4"	TCA112114	25	TEHB150125	10	-	-	-	

Straight Hose Barbs **CONTINUED** on next page.

PIPE FITTINGS

		Part Numbers by Material						
		Std Poly	Std Poly Bag Qty	Banjo Poly	Banjo Poly Bag Qty	Plated Steel	Stainless Steel	Brass
 <p>Straight Hose Barbs Continued (mpt x hose barb)</p>	Size							
	1 1/2"	TCA112	25	TEHB150	10	TC219	TC219SS	-
	1 1/2" x 2"	-	-	TEHB150200	10	-	-	-
	2" x 1 1/2"	-	-	TEHB200150	10	-	-	-
	2"	TCA200	25	TEHB200	10	TC220	TC220SS	-
	3"	-	-	TEHB300	-	TC300	TC300SS	-
4"	-	-	TEHB400	-	TC400	-	-	
<p>Female Straight Hose Barbs (fpt x hose barb)</p>	1/4"	TCAF1414	25	-	-	-	-	-
	1/4" x 3/8"	TCAF1438	25	-	-	-	-	-
	3/8"	TCAF3838	25	-	-	-	-	-
	1/2"	TCQ1212	25	-	-	-	-	-
	3/4"	-	-	TEHBF075	10	-	-	-
	3/4" x 1"	-	-	TEHBF075100	10	-	-	-
1"	-	-	TEHBF100	10	-	-	-	
<p>Garden Hose Thread Straight Hose Barbs (mght x hose barb)</p>	3/4" x 1/4"	TCD3414	25	-	-	-	-	-
	3/4" x 3/8"	TCD3438	25	-	-	-	-	TC201B
	3/4" x 1/2"	TCD3412	25	-	-	TC203	-	TC203B
	3/4" x 5/8"	TCD3458	25	-	-	TC204	-	TC204B
	3/4"	TCD3434	25	-	-	TC205	-	TC205B
	3/4" x 1"	TCD3410	25	-	-	-	-	-
 <p>90° Hose Barbs (mpt x hose barb)</p>	1/8" x 1/4"	TCEL1814	25	-	-	-	-	-
	1/4"	TCEL1414	25	TEEL025HB	10	-	-	-
	1/4" x 3/8"	TCEL1438	25	TEEL025038HB	10	-	-	-
	1/4" x 1/2"	TCEL1412	25	TEEL025050HB	10	-	-	-
	3/8"	TCEL3838	25	TEEL038HB	10	-	-	-
	1/2" x 3/8"	TCEL1238	25	TEEL050038HB	10	-	-	-
	1/2"	TCEL1212	25	TEEL050HB	10	-	-	-
	1/2" x 3/4"	TCEL1234	25	TEEL050075HB	10	-	-	-
	3/4" x 1/2"	TCEL3412	25	TEEL075050HB	10	-	-	-
	3/4"	TCEL3434	25	TEEL075HB	10	-	-	-
	3/4" x 1"	TCEL3410	25	TEEL075100HB	10	-	-	-
	1" x 3/4"	TCEL1034	25	TEEL100075HB	10	-	-	-
	1"	TCEL1010	25	TEEL100HB	10	-	-	-
	1" x 1 1/4"	-	-	TEEL100125HB	10	-	-	-
	1 1/4" x 1"	TCEL1141	-	TEEL125100HB	10	-	-	-
	1 1/4"	TCEL1114	-	TEEL125HB	10	-	-	-
	1 1/4" x 1 1/2"	TCEL114112	-	TEEL125150HB	10	-	-	-
	1 1/2" x 1 1/4"	-	-	TEEL150125HB	10	-	-	-
	1 1/2"	TCEL112	-	TEEL150HB	10	-	-	-
	2" x 1 1/2"	-	-	TEEL200150HB	10	-	-	-
2"	TCEL200	-	TEEL200HB	10	-	-	-	
3"	-	-	TEEL300HB	-	-	-	-	
<p>Male Garden Hose Thread Adapters (mght x size m or f)</p>	3/4" x 3/8" m	TCE3438	25	-	-	-	-	-
	3/4" x 1/2" m	TCE3412	25	-	-	TC273	-	TC273B
	3/4" m	TCE3434	25	-	-	-	-	TC275B
	3/4" x 1/4" f	TCG3414	25	-	-	-	-	-
	3/4" x 1/2" f	TCG3412	25	-	-	-	-	TCGHM12F
	3/4" f	TCG3434	25	-	-	-	-	TCGHM34F

PIPE FITTINGS

		Part Numbers by Material					
	Size	Std Poly	Std Poly Bag Qty	Swivel	Plated Steel	Brass	
Female Garden Hose Thread Adapters (fght x size m or f)	¾" x ½" m	-	-	-	-	TCGHF12	
	¾" x ½" f	TCJ3412	25	-	-	TCGHF12F	
	¾" x ¾" m	TCH3434	25	-	-	-	
	¾" x ¾" f	-	-	TCGHF34FS	-	TCGHF34F	
	fght x fght	-	-	-	-	TCGHFGHF	
Female Garden Hose Thread x Male Garden Hose Thread Adapter		¾" x ¾"	TCI3434	25	-	-	
Female Garden Hose Cap-Knurled		¾"	TCN3400	25	-	-	
Female Garden Hose Swivel Nut		¾"	TCB3400	25	-	TC270 TC270B	
Female Pipe Straight Swivel Nut-Hex		¾" 1"	TCB3500 -	25 -	- -	TC385 TC387 -	
Flat Seat Hose Barb		¼" ⅜" ½" ⅝" ¾" 1"	TCC014 TCC038 TCC012 TCC058 TCC034 TCC100	25 25 25 25 25 25	- TC266 TC267 - - -	- - TC263 - TC295 -	TC260B TC261B TC263B TC264B TC265B -
Female Swivel Hex Nut w/Ball-Seat Hose Barb Insert		¼" ¼" x ⅜" ⅜" ½"	- - - -	- - - -	- - - -	- - - -	TC472 TC473 TC475 TC480

	Description	Part No.	Std Bag Qty
Swivel Nut Gaskets/Washers	Black Poly	TCW405	100
	Stainless Filter 50/60 mesh	TCW407	100
	Monel	TCW410	100
	1" washer	TCW409	-

	Part No.	Description
 Poly Manifolds	TETM075050	Banjo 8 station manifold, ¾" inlet, ½" outlets, ¼" gauge port
	DE36516-3	Delavan 8 station manifold, ¾" inlet, ½" outlets, ¼" gauge port
Poly Swivels	TESW100	Banjo 1" Male x 1" Female swivel
	TESW150	Banjo 1 ½" Male x 1 ½" Female swivel
	TESW200	Banjo 2" Male x 2" Female swivel

Hose Clamps 5/16" Band	Std Part No.	Stainless Part No.	Min/Max Diameter	Std Box Qty	Recommended for Hose Size*
	DUGS4 DUGS6	DUGS4SS DUGS6SS	7/32" - 5/8" 5/16" - 7/8"	10 10	¼" ⅜"

Hose Clamps **CONTINUED** on next page. *Hose sizes based on inside diameter. **Thick-walled hoses may require next clamp size up.**

PIPE FITTINGS

	Std Part No.	Stainless Part No.	Min/Max Diameter	Std Box Qty	Recommended for Hose Size*
Hose Clamps ½" Band	DUH06	DUH06SS	¾" - 7/8"	10	¾"
	DUH08	DUH08SS	7/16" - 1"	10	½"
	DUH10	DUH10SS	9/16" - 1 1/16"	10	5/8"
	DUH12	DUH12SS	9/16" - 1 ¼"	10	¾"
	DUH16	DUH16SS	1 1/16" - 1 ½"	10	1"
	DUH20	DUH20SS	¾" - 1 ¾"	10	1 ¼"
	DUH24	DUH24SS	1 1/16" - 2"	10	1 ½"
	DUH28	DUH28SS	1 5/16" - 2 ¼"	10	1 ¾"
	DUH32	DUH32SS	1 9/16" - 2 ½"	10	2"
	DUH36	DUH36SS	1 13/16" - 2 ¾"	10	2 ¼"
	DUH40	DUH40SS	2 1/16" - 3"	10	2 ½"
	DUH44	DUH44SS	2 5/16" - 3 ¼"	10	2 ¾"
	DUH48	DUH48SS	2 9/16" - 3 ½"	10	3"
	DUH52	DUH52SS	2 13/16" - 3 ¾"	10	3 ¼"
	DUH56	DUH56SS	3 1/16" - 4"	10	3 ½"
	DUH60	DUH60SS	3 5/16" - 4 ¼"	10	3 ¾"
	DUH64	DUH64SS	3 9/16" - 4 ½"	10	4"
	DUH72	DUH72SS	4 1/16" - 5"	10	4 ½"
	DUH96	DUH96SS	4 ½" - 6 ½"	10	6"
	DUH104	DUH104SS	5" - 7"	10	6 ½"









*Hose sizes based on inside diameter. **Thick-walled hoses may require next clamp size up.**

	Std Part No.	Recommended for Hose Size*	Min/Max Diameter	Std Bag Qty
 T-bolt Hose Clamps	TETC162	1 ¼"	1.62"/1.87"	10
	TETC181	1 ½"	1.81"/2.06"	10
	TETC193	1 ½"	1.93"/2.18"	10
	TETC218	2"	2.18"/2.50"	10
	TETC231	2"	2.31"/2.62"	10
	TETC250	2"	2.50"/2.81"	10
	TETC287	2"	2.87"/3.18"	10
	TETC331	3"	3.31"/3.62"	10
	TETC343	3"	3.43"/3.75"	10
	TETC425	4"	4.25"/4.56"	10
	TETC438	4"	4.38"/4.76"	10
	TETC456	4"	4.56"/4.94"	10

*Hose sizes based on inside diameter. **Thick-walled hoses may require next clamp size up.**







	Type	Part No.	Size	Container
 Pipe Sealant	Liquid Rector Seal Black	TC28651	½ pint	can
	Liquid Teflon	TCLT2	2 oz.	tube
	Tape Teflon	TAPE260	½" x 260'	spool

**MANIFOLD FITTINGS**

	Part No.	Description	Bag Qty
Flanged Couplings 	TEM100CPG	1"	10
	TEM200CPG	2" Standard Port	10
	TEM220CPG	2" Full Port	10
	TEM220CPG6	2" Full Port x 6"	1
	TEM300CPG	3" Full Port	1
	TEM300CPG7	3" Full Port x 7"	1
90° Flanged Couplings 	TEM100CPG90	1"	10
	TEM200CPG90	2" Standard Port	1
	TEM220CPG90	2" Full Port	1
	TEM300CPG90	3"	1
45° Flanged Couplings 	TEM100CPG45	1"	10
	TEM200CPG45	2" Standard Port	10
	TEM220CPG45	2" Full Port	10
	TEM300CPG45	3"	1
Flanged Reducer Couplings 	TEM200100CPG	2" Standard Port X 1"	10
	TEM220200CPG	2" Full Port X 2" Std Port	10
	TEM300200CPG	3" x 2" Standard Port	1
	TEM300220CPG	3" X 2" Full Port	1
Flanged Tee 	TEM100TEE	1"	10
	TEM200100TEE	2" Standard Port X 1"	1
	TEM200100TEEB	2" Standard Port X 1" w/mounting bracket	1
	TEM220100TEE	2" Full Port x 1"	1
	TEM200TEE	2" Standard Port	1
	TEM220TEE	2" Full Port	1
	TEM300TEE	3"	1
Flanged Y Couplings	TEM220Y45	2" Full Port Y 45°	10
	TEM220YG45	2" Full Port Y 45° w/3/4" gauge port	10
	TEM300Y45	2" Full Port Y 45°	1
Flange X Female Thread 	TEM100050FPT	1" Flange X 1/2" Female thread	10
	TEM100075FPT	1" Flange X 3/4" Female thread	10
	TEM100FPT	1" Flange X 1" Female thread	10
	TEM200FPT	2" Standard Port Flange X 2" Female thread	1
	TEM220FPT	2" Full Port Flange X 2" Female thread	1
	TEM300FPT	3" Flange X 3" Female thread	1
Flange X Male Thread 	TEM100075MPT	1" Flange X 3/4" Male thread	10
	TEM100MPT	1" Flange X 1" Male thread	10
	TEM100125MPT	1" Flange X 1 1/4" Male thread	10
	TEM200125MPT	2" Standard Port Flange X 1 1/4" Male thread	10
	TEM200150MPT	2" Standard Port Flange X 1 1/2" Male thread	10
	TEM200MPT	2" Standard Port Flange X 2" Male thread	1
	TEM220MPT	2" Full Port Flange X 2" Male thread	1
	TEM300MPT	3" Flange X 3" Male thread	1
Flange Plugs (solid & with Female gauge port) 	TEM100PLG	1" Flange Plug	10
	TEM200PLG	2" Standard Port Plug	10
	TEM220PLG	2" Full Port Flange Plug	10
	TEM300PLG	3" Flange Plug	10
	TEM100PLG025	1" Flange Plug w/1/4" Female thread	10
	TEM200PLG018	2" Standard Port Flange Plug w/1/8" Female thread	10
	TEM200PLG025	2" Standard Port Flange Plug w/1/4" Female thread	10
	TEM200PLG038	2" Standard Port Flange Plug w/3/8" Female thread	10
	TEM200PLG050	2" Standard Port Flange Plug w/1/2" Female thread	10
	TEM200PLG075	2" Standard Port Flange Plug w/3/4" Female thread	10
	TEM200PLG100	2" Standard Port Flange Plug w/1" Female thread	10
	TEM220PLG075	2" Full Port Flange Plug w/3/4" Female thread	10
	TEM300PLG075	3" Flange Plug w/3/4" Female thread	10
	TEM300PLG100	3" Flange Plug w/1" Female thread	10



MANIFOLD FITTINGS

Flange Cross	Part No.	Description	Case/Bag Qty.
	TEM100CR	1" Flanged Cross	10
	TEM200CR	2" Standard Port Cross	1
	TEM220CR	2" Full Port Cross	1
	TEM300CR	3" Flanged Cross	1
Flange X Male Quick Coupler 	TEM100A TEM200A TEM220A TEM300A	1" Flange X 1" Male Quick Coupler 2" Standard Port Flange X 2" Male Quick Coupler 2" Full Port Flange X 2" Male Quick Coupler 3" Flange X 3" Male Quick Coupler	10 10 10 1
Flange X Hose Barb 	TEM100075BRB TEM100BRB TEM100125BRB TEM200100BRB TEM200125BRB TEM200150BRB TEM200BRB TEM220125BRB TEM220150BRB TEM220BRB TEM300220BRB TEM300BRB	1" Flange X 3/4" Hose Barb 1" Flange X 1" Hose Barb 1" Flange X 1 1/4" Hose Barb 2" Standard Port Flange X 1" Hose Barb 2" Standard Port Flange X 1 1/4" Hose Barb 2" Standard Port Flange X 1 1/2" Hose Barb 2" Standard Port Flange X 2" Hose Barb 2" Full Port Flange X 1 1/4" Hose Barb 2" Full Port Flange X 1 1/2" Hose Barb 2" Full Port Flange X 2" Hose Barb 3" Flange X 2" Hose Barb 3" Flange X 3" Hose Barb	10 10 10 10 10 10 10 1 1 1 1 1
Flange X Hose Barb Elbow, 90° 	TEM100075BRB90 TEM100BRB90 TEM100125BRB90 TEM100150BRB90 TEM200100BRB90 TEM200125BRB90 TEM200150BRB90 TEM200BRB90 TEM220150BRB90 TEM220BRB90 TEM300220BRB90 TEM300BRB90	1" Flange X 3/4" Hose Barb Elbow 1" Flange X 1" Hose Barb Elbow 1" Flange X 1 1/4" Hose Barb Elbow 1" Flange X 1 1/2" Hose Barb Elbow 2" Standard Port Flange X 1" Hose Barb Elbow 2" Standard Port Flange X 1 1/4" Hose Barb Elbow 2" Standard Port Flange X 1 1/2" Hose Barb Elbow 2" Standard Port Flange X 2" Hose Barb Elbow 2" Full Port Flange X 1 1/2" Hose Barb Elbow 2" Full Port Flange X 2" Hose Barb Elbow 3" Flange X 2" Hose Barb Elbow 3" Flange X 3" Hose Barb Elbow	10 10 10 10 10 10 10 10 1 1 1 1
Flange X Hose Barb Elbow, 45°	TEM100BRB45 TEM200BRB45 TEM220BRB45 TEM300BRB45	1" Flange X 1" Hose Barb Elbow 2" Standard Port Flange X 2" Hose Barb Elbow 2" Full Port Flange X 2" Hose Barb Elbow 3" Flange X 3" Hose Barb Elbow	10 10 10 10
Flange X Hose Barb Tee	TEM100100HBT	1" Flange X 1" Hose Barb Tee	10
Flange Clamps and Gaskets 	TEFC100 TEFC200 TEFC220 TEFC300 TEM100G TEM100GV OP150G OP150GV OP200G OP200GV OP300G OP300GV	100 Series Worm Screw Flange Clamp 200 Series Worm Screw Flange Clamp 220 Series Worm Screw Flange Clamp 300 Series Worm Screw Flange Clamp 100 Series EPDM Gasket 100 Series Viton Gasket 200 Series EPDM Gasket 200 Series Viton Gasket 220 Series EPDM Gasket 220 Series Viton Gasket 300 Series EPDM Gasket 300 Series Viton Gasket	10 10 10 10 1 1 1 1 1 1 1 1
U Bolts 	TEUB100 TEUB202 TEUB220	100 Series Mounting U-Bolt, SS 200 Series Mounting U-Bolt, SS 220 Series Mounting U-Bolt, SS	1 1 1

TEEJET DIRECTOVALVE FLANGES AND QUICK CONNECTIONS

FLANGED FITTINGS

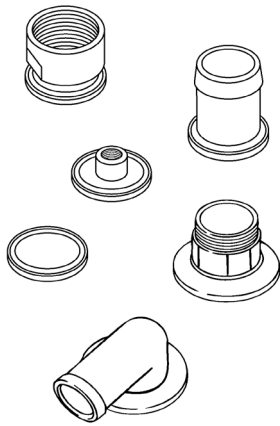

50 Series Flanged Fittings: (interchanges with Banjo Series 100)

- SP48150 50 Series x 3/4" Hose Barb
- SP45504 50 Series x 1" Hose Barb
- SP45505 50 Series x 1 1/4" Hose Barb
- SP45506 50 Series x 1 1/2" Hose Barb
- SP48151 50 Series x 3/4" 90° Hose Barb Elbow
- SP48152 50 Series x 1" 90° Hose Barb Elbow
- SP45507 50 Series x Blank
- SP46029 50 Series x Male Quick Connect
- SP48157 50 Series x 50 Series Straight Coupling
- SP48158 50 Series x 50 Series Elbow Coupling

75 Series Flanged Fittings: (interchanges with Banjo Series 200)

- SP48160 75 Series x 1 1/4" Hose Barb
- SP46067 75 Series x 1 1/2" Hose Barb
- SP48161 75 Series x 2" Hose Barb
- SP48162 75 Series x 1 1/4" 90° Hose Barb Elbow
- SP48163 75 Series x 1 1/2" 90° Hose Barb Elbow
- SP48164 75 Series x 2" 90° Hose Barb Elbow
- SP46069 75 Series x Blank
- SP48169 75 Series x 75 Series Straight Coupling
- SP48168 75 Series x 75 Series Elbow Coupling
- SP46716 75 Series x 75 Series x 75 Series Tee
- SP46717 75 Series x 75 Series x 50 Series Tee
- SP45207 75 Series x 50 Series Reducer
- SP45251 75 Series Tee Body

FLANGED CLAMPS

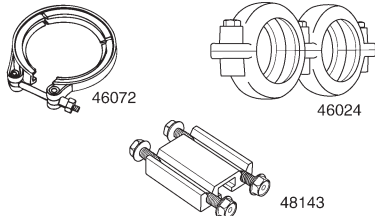

- SP46024 #50 Series 3 way Clamp and O-ring Kit
- SP46072-50 #50 Series Stainless Steel Clamp & O-ring Kit
- SP46072-75 #75 Series Stainless Steel Clamp & O-ring Kit
- SP48143 Bar Mounting Kit

QUICK CONNECT FITTINGS FOR AA450 & AA460 MANIFOLDS

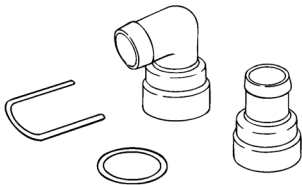

- SP45529-1/2 1/2" Straight Hose Barb
- SP45529-3/4 3/4" Straight Hose Barb
- SP45529-1 1" Straight Hose Barb
- SP45529-90-1/2 1/2" 90° Hose Barb Elbow
- SP45529-90-3/4 3/4" 90° Hose Barb Elbow
- SP45529-90-1 1" 90° Hose Barb Elbow

AA440 MANIFOLD INLET/BYPASS CONNECTIONS

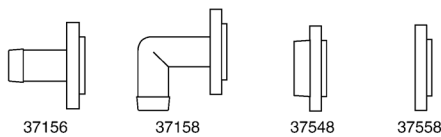





- SP37156 1" Straight Hose Barb
- SP37158 1" 90° Hose Barb Elbow
- SP37558 Blank Inlet

QUICK COUPLERS



(Cam-Lever Couplings)



	Size	PSI	Bag Qty*	BANJO POLYPROPYLENE	STAINLESS STEEL	ALUMINUM
 <p>PART A</p> <p>Male Cam x Female Pipe Thread</p>	3/4"	125	10	OP075AP	OP075ASS	OP075AL
	1"	125	10	OP100AP	OP100ASS	OP100AL
	1 1/4"	125	-	OP125AP	OP125ASS	OP125AL
	1 1/2"	125	10	OP150AP	OP150ASS	OP150AL
	1 1/2" 90°	125	-	OP15090AP	-	-
	2"	125	10	OP200AP	OP200ASS	OP200AL
	2" 90°	125	-	OP20090AP	-	-
	3"	75	-	OP300AP	OP300ASS	OP300AL
	4"	75	-	OP400AP	OP400ASS	OP400AL
 <p>PART B</p> <p>Female Cam x Male Pipe Thread</p>	3/4"	125	10	OP075BP	OP075BSS	OP075BL
	1"	125	10	OP100BP	OP100BSS	OP100BL
	1 1/4"	125	-	OP125BP	OP125BSS	OP125BL
	1 1/2"	125	10	OP150BP	OP150BSS	OP150BL
	2"	125	10	OP200BP	OP200BSS	OP200BL
	3"	75	-	OP300BP	OP300BSS	OP300BL
	4"	75	-	OP400BP	OP400BSS	OP400BL
	 <p>PART C</p> <p>Female Cam x Hose Barb</p>	3/4"	125	10	OP075CP	OP075CSS
1"		125	10	OP100CP	OP100CSS	OP100CL
1 1/4"		125	-	OP125CP	OP125CSS	OP125CL
1 1/2"		125	-	OP150CP	OP150CSS	OP150CL
1 1/2" 90°		125	-	OP15090CP	-	-
2"		125	-	OP200CP	OP200CSS	OP200CL
2" 90°		125	-	OP20090CP	-	-
3"		75	-	OP300CP	OP300CSS	OP300CL
4"		75	-	OP400CP	OP400CSS	OP400CL
 <p>PART D</p> <p>Female Cam x Female Pipe Thread</p>	3/4"	125	10	OP075DP	OP075DSS	OP075DL
	1"	125	10	OP100DP	OP100DSS	OP100DL
	1 1/4"	125	-	OP125DP	OP125DSS	OP125DL
	1 1/2"	125	-	OP150DP	OP150DSS	OP150DL
	1 1/2" 90°	125	-	OP15090DP	-	-
	2"	125	-	OP200DP	OP200DSS	OP200DL
	2" 90°	125	-	OP20090DP	-	-
	3"	75	-	OP300DP	OP300DSS	OP300DL
	4"	75	-	OP400DP	OP400DSS	OP400DL
 <p>PART E</p> <p>Male Cam x Hose Barb</p>	3/4"	125	10	OP075EP	OP075ESS	OP075EL
	1"	125	10	OP100EP	OP100ESS	OP100EL
	1 1/4"	125	-	OP125EP	OP125ESS	OP125EL
	1 1/2"	125	10	OP150EP	OP150ESS	OP150EL
	2"	125	10	OP200EP	OP200ESS	OP200EL
	3"	75	-	OP300EP	OP300ESS	OP300EL
	4"	75	-	OP400EP	OP400ESS	OP400EL
	 <p>PART F</p> <p>Male Cam x Male Pipe Thread</p>	3/4"	125	10	OP075FP	OP075FSS
1"		125	10	OP100FP	OP100FSS	OP100FL
1 1/4"		125	-	OP125FP	OP125FSS	OP125FL
1 1/2"		125	-	OP150FP	OP150FSS	OP150FL
1 1/2" 90°		125	-	OP15090FP	-	-
2"		125	-	OP200FP	OP200FSS	OP200FL
2" 45°		125	-	OP20045FP	-	-
2" 90°		125	-	OP20090FP	-	-
3"		75	-	OP300FP	OP300FSS	OP300FL
4"		75	-	OP400FP	OP400FSS	OP400FL

* Bag quantities listed here are applicable only to polypropylene couplers.

QUICK COUPLERS (Cam-Lever Couplings)

 PART H Female Cam Cap	Size	PSI	Bag Qty*	BANJO POLYPROPYLENE	STAINLESS STEEL	ALUMINUM
	 PART I Male Cam Plug	3/4" 1" 1 1/4" 1 1/2" 2" 3" 4"	125 125 125 125 125 50 50	10 10 - - - - -	OP075HP OP100HP OP125HP OP150HP OP200HP OP300HP OP400HP	OP075HSS OP100HSS OP125HSS OP150HSS OP200HSS OP300HSS OP400HSS
Banjo Specialty Couplers Spool Adapter, Male Cam x Male Cam 3-Arm Part C 2 1/2" Plug 2 1/2" Cap 2" Female Coupler X 1 1/2" Hose Barb	2" 3" 2 1/2" 2 1/2" 2"	125 75 75 50 125	- - - - -	OP200FF OP303CP OP250IP OP250HP OP200150CP	All Specialty Couplers are special order items.	

* Bag quantities listed here are applicable only to polypropylene couplers.

REPLACEMENT PARTS for Banjo Quick Couplers

Description	Size	Material			Part No.
		EPDM	Viton	Buna	
Gasket	3/4" 1" 1 1/4" 1 1/2" 2" 2 1/2" 3" 4"	OP075G OP100G OP125G OP150G OP200G OP250G OP300G OP400G	OP075GV OP100GV OP125GV OP150GV OP200GV OP250GV OP300GV OP400GV	OP075GB OP100GB - OP150GB OP200GB - OP300GB OP400GB	
Extra-Thick Gasket	3/4" 1" 1 1/2" 2" 3" 4"	OP075GXT OP100GXT OP150GXT OP200GXT OP300GXT OP400GXT	- - OP150GVXT OP200GVXT OP300GVXT -		
Cam Arm w/Ring	3/4" 1" 1 1/2" 2" 3" 4"				OP075K OP100K OP200K OP200K OP300K OP300K
Cam Pin Stainless	3/4" 1" 1 1/2" 2" 3" 4"				OP075P OP100P OP200P OP200P OP300P OP300P
Stainless Ring	1" 1 1/2" 2" 3"				OP100R OP200R OP200R OP200R

POLYPROPYLENE LOCKING QUICK COUPLERS

ENHANCED SAFETY-

Cam Lever Lock helps reduce the possibility of unintentional opening of the cam levers, which could result in personal injury & costly spills.



**CAM LEVER
COUPLINGS**



Description	Size	PSI	Banjo Part No.	Gator Lock Part No.
PART B- Female Cam x Male Pipe Thread	3/4"	-	-	OPGL075B
	1"	-	-	OPGL100B
	1 1/2"	125	OPL150B	OPGL150B
	2"	125	OPL200B	OPGL200B
PART C- Female Cam x Hose Barb	3/4"	-	-	OPGL075C
	1"	-	-	OPGL100C
	1 1/2"	125	OPL150C	OPGL150C
	2"	125	OPL200C	OPGL200C
PART D- Female Cam x Female Pipe Thread	3/4"	-	-	OPGL075D
	1"	-	-	OPGL100D
	1 1/2"	125	OPL150D	OPGL150D
	2"	125	OPL200D	OPGL200D
PART H- Female Cam Cap	3/4"	-	-	OPGL075H
	1"	-	-	OPGL100H
	1 1/2"	125	OPL150H	OPGL150H
	2"	125	OPL200H	OPGL200H

PLEASE NOTE that locking cam lever arms do not prevent unauthorized opening of the coupling and are not a security device.



Garden Hose Fittings

FEATURES

- Quick and simple way to connect and disconnect your garden hose!
- Easily connects hose to spigot, sprinkler, nozzle or other hose end accessories.
- Durable, rustproof polypropylene construction.
- Never have to use pliers to tighten to prevent leaks.
- Yellow fiberglass reinforced polypropylene.
- Standard $\frac{3}{4}$ " opening diameter.



OPGH075A



OPGH075B



OPGH075D



OPGH075F



TEGHMFT



TEGHFMT



SPECIAL CAM LOCKS



Cam-lock reducers are available only by special order. Call Spray Tech for price and availability.

SPECIAL CAM LOCKS

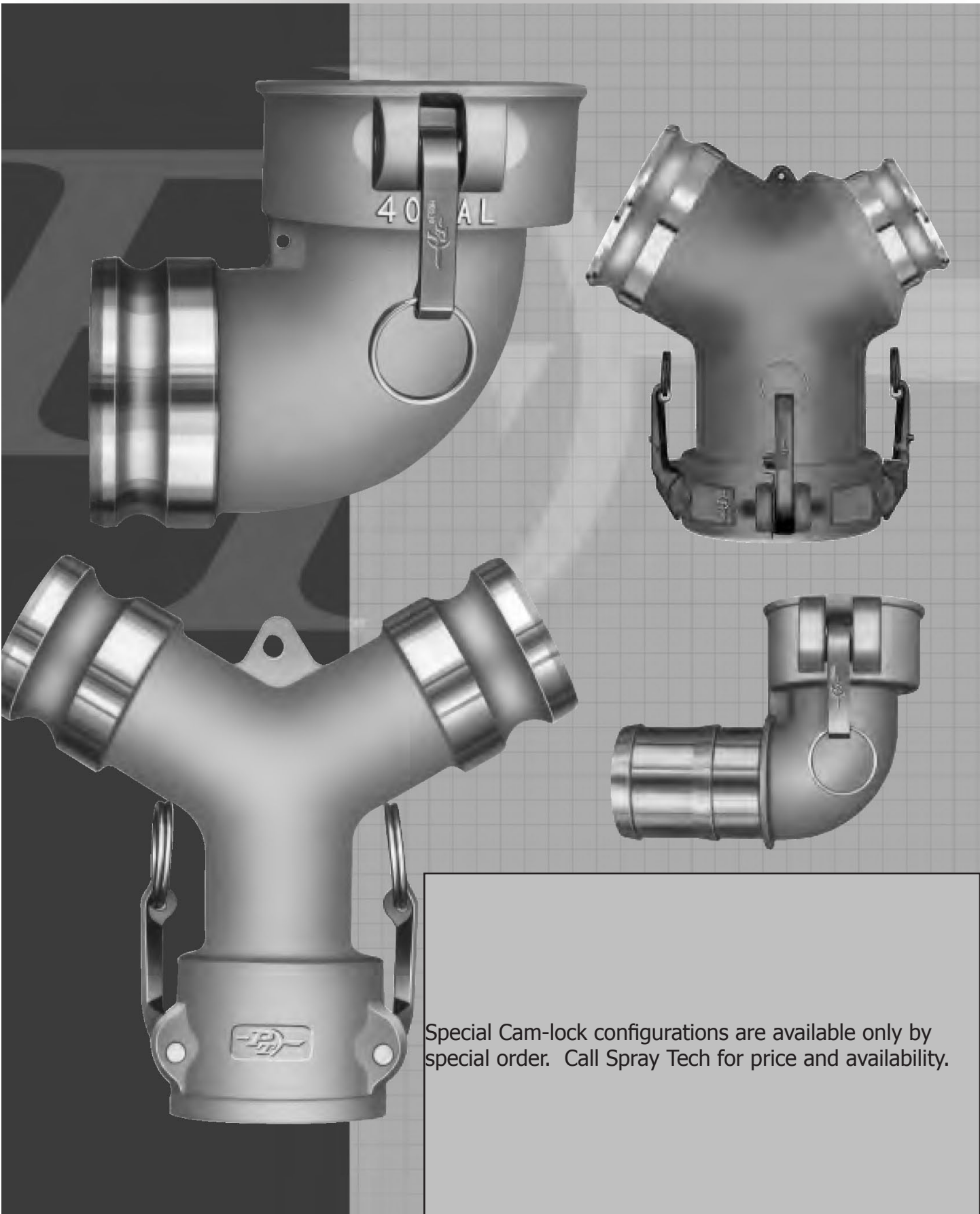

Special Cam-lock configurations are available only by special order. Call Spray Tech for price and availability.

GAUGES



OEM Gauges (single scale)

MODEL 41



Pressure Range PSI	Part Number by Size		
	2"	2 1/2"	4"
30 Vac - 0	-	GA030VG	-
30 Vac - 0 - 100	-	GA030100VG	-
0 - 30	-	GA030G	-
0 - 60	-	GA060G	-
0 - 100	-	GA100G	-
0 - 100 BACK MOUNT	-	GA100CG	-
0 - 160	-	GA160G	-
0 - 200	-	GA200G	-
0 - 300	-	GA300G	-
0 - 400	-	GA400G	-
0 - 600	-	GA600G	-
0 - 1000	-	GA1000G	-
0 - 2000	-	GA2000G	-
0 - 3000	-	GA3000G	-
0 - 4000	-	GA4000G	-
0 - 5000	-	GA5000G	-
0 - 6000	-	GA6000G	-
0 - 10000 (dual scale)	-	GA10000G	-

DESCRIPTION

2 1/2" Casing. Center Back, Bottom Mount. These gauges are designed for use with any medium not corrosive to brass or bronze. Liquid-filled gauges are recommended for reducing shock caused by pressure fluctuations or vibration. Liquid filled standard.

Back-mount gauges may be available in more pressure ranges. Call Spray Tech for more information.

FEATURES

Movement	Brass
Bourdon Tube	C-Shaped in copper alloy up to 1000 PSI and Helical in phosphor bronze above 1000 PSI.
Pointer	Black enameled aluminum
Dial	White aluminum
Window	Acrylic
Case Material	304 Stainless steel
Connection Material	Brass
Connection Size	1/4" MNPT
Accuracy	ASME/ANSI B40.1 Grade B (3-2-3%)
Fill Material	Dry, Glycerin
Wetted Parts	Copper Alloy

CASE STYLE AND DIMENSIONS

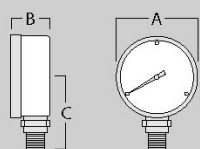

Bottom Mount

Size	A"	B"	C"	D"	E"
2 1/2"	2.670	1.100	2.270	2.460	n/a

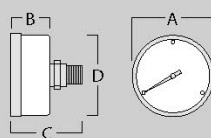

Back Mount

Size	A"	B"	C"	D"	E"
2 1/2"	2.630	1.120	2.214	2.470	n/a

Available by special order only. Please call for details.

* IMPORTANT GAUGE TROUBLESHOOTING TIP *

In cases where the gauge needle will not return to zero, the gauge has exceeded its pressure capacity - recommend to your customer that he should buy a gauge with a higher pressure range for a replacement.

General Service Gauges (single scale)

MODEL 24

Pressure Range PSI	Part Number by Size		
	2"	2 1/2"	4"
0 - 30	GA030	GA0302-5	GA0304
0 - 60	GA060	GA0602-5	GA0604
0 - 100	GA100	GA1002-5	GA1004
0 - 200	GA200	GA2002-5	GA2004
0 - 300	GA300	GA3002-5	GA3004
0 - 400	GA400	GA4002-5	GA4004
0 - 500	GA500	GA5002-5	GA5004
0 - 600	GA600	GA6002-5	GA6004
0 - 1000	GA1000	GA10002-5	GA10004



CASE STYLE AND DIMENSIONS

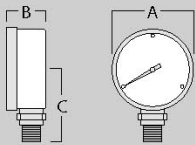

Bottom Mount

Size	A"	B"	C"	D"	E"
2"	2.016	1.109	1.687	n/a	n/a
2 1/2"	2.469	1.187	1.828	n/a	n/a
4"	3.969	1.266	2.734	n/a	n/a

DESCRIPTION

2", 2 1/2", and 4" Casing. Bottom Mount only. These gauges are designed for use with gas, oil, and water or any medium not corrosive to brass or bronze.

FEATURES

Movement	Brass
Bourdon Tube	C-Shaped in copper alloy up to 600 PSI and Helical in phosphor bronze above 600 PSI.
Pointer	Black enameled aluminum
Dial	White aluminum
Window	Acrylic
Case Material	black steel
Bezel	Black
Connection Material	Brass
Connection Size	1/4" MNPT
Accuracy	ASME/ANSI B40.1 Grade B (3-2-3%)
Fill Material	Dry only
Wetted Parts	Copper Alloy

* IMPORTANT GAUGE TROUBLESHOOTING TIP *

In cases where the gauge needle will not return to zero, the gauge has exceeded its pressure capacity - recommend to your customer that he should buy a gauge with a higher pressure range for a replacement.

All Stainless Steel OEM Gauges (single scale)

MODEL 54

Pressure Range	Part Number by Size		
	2"	2 1/2"	4"
0 - 30	-	GA030GSS	*
0 - 60	-	GA060GSS	*
0 - 100	-	GA100GSS	*
0 - 160	-	GA160GSS	*
0 - 200	-	GA200GSS	*
0 - 300	-	GA300GSS	*
0 - 400	-	GA400GSS	*
0 - 600	-	GA600GSS	*
0 - 1000	-	GA1000GSS	*
0 - 2000	-	GA2000GSS	*
0 - 3000	-	GA3000GSS	*
0 - 3000 BACK MOUNT	-	GA3000CG	-
0 - 5000	-	GA5000GSS	*
0 - 6000	-	GA6000GSS	*
0 - 10000	-	GA10000GSS	*

Back-mount gauges may be available in more pressure ranges. * May be available in 4" model. Call Spray Tech for more information.



CASE STYLE AND DIMENSIONS

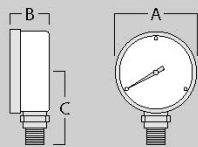

Bottom Mount

Size	A"	B"	C"	D"	E"
2 1/2"	2.672	1.109	2.250	2.460	n/a
4"	4.344	1.828	3.391	3.970	n/a

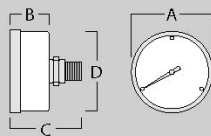

Back Mount

Size	A"	B"	C"	D"	E"
2 1/2"	2.672	1.109	2.250	2.460	n/a
4"	4.344	1.828	3.391	3.970	n/a

DESCRIPTION

2 1/2" and 4" Casing. Center Back, Bottom

Mount. These gauges are designed for use with any medium not corrosive to stainless steel.

Liquid-filled gauges are recommended for reducing shock caused by pressure fluctuations or vibration.

FEATURES

Movement	Stainless Steel
Bourdon Tube	316 Stainless Steel
Pointer	Black enameled aluminum
Dial	White aluminum
Window	Polycarbonate
Case Material	304 Stainless Steel
Connection Material	316 Stainless Steel
Connection Size	1/4" MNPT standard
Accuracy	ASME/ANSI B40.1 Grade B (3-2-3%)
Fill Material	Dry, Glycerin (std.), Silicone, Florolube
Wetted Parts	Stainless Steel

* IMPORTANT GAUGE TROUBLESHOOTING TIP *

In cases where the gauge needle will not return to zero, the gauge has exceeded its pressure capacity - recommend to your customer that he should buy a gauge with a higher pressure range for a replacement.



Ammonia Gauges (single scale)

MODEL 80



Pressure Range	Part Number by Size		
	2"	2 1/2"	4"
0 - 60	-	GAASG60	-

Additional pressure ranges may be available. Call Spray Tech for more information.

DESCRIPTION

2½" and 4" Casing. Bottom Mount only. This rugged product employs a 316 Stainless Steel bourdon tube, ASME grade A movement, and a Stainless Steel socket all housed in a corrosive resistant painted steel case. This gauge is of the highest quality and is very competitively priced.

FEATURES

Movement	316 Stainless Steel
Bourdon Tube	316 Stainless Steel
Pointer	Black enameled aluminum
Dial	White aluminum
Window	Acrylic
Case Material	Enameled steel
Connection Material	Stainless Steel
Connection Size	¼" MNPT
Accuracy	ASME/ANSI B40.1 Grade A (2-1-2%)
Fill Material	Dry only
Wetted Parts	Stainless Steel

CASE STYLE AND DIMENSIONS

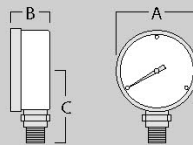

Bottom Mount

Size	A"	B"	C"	D"	E"
2½"	2.469	1.187	1.828	n/a	n/a
4"	3.969	1.266	2.734	n/a	n/a

* IMPORTANT GAUGE TROUBLESHOOTING TIP *

In cases where the gauge needle will not return to zero, the gauge has exceeded its pressure capacity - recommend to your customer that he should buy a gauge with a higher pressure range for a replacement.

SPRAY GUNS

GUNJET SPRAY GUNS

GUNJET® SPRAY GUNS

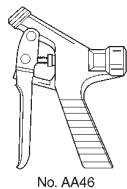
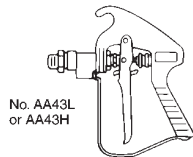
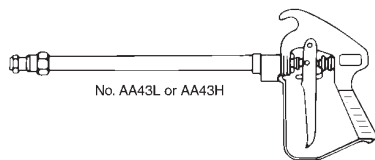
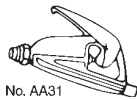
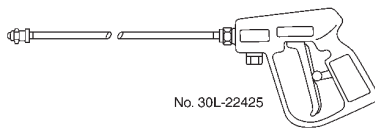
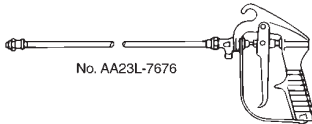
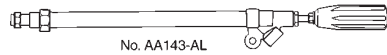
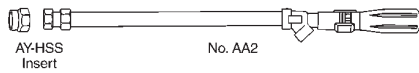

▲ #2 Gunjet
 SP2RK Repair Kit for #2 Gunjet
 SP12-6 #12 Gunjet
 SP12-6AL #12 Gunjet Aluminum
 SP12RK Repair Kit for #12 Gunjet
 SP18-6AL #18 Gunjet Aluminum
 SP18ALRK Repair Kit for #18 Gunjet

SP143-ALGHT GunJet Aluminum

SP23L Brass Inlet Body and Cap, less Tip
 SP23LRK Repair Kit for SP23L Gunjet
 SP23H Brass Inlet Body and Cap, less Tip
 SP23HRK Repair Kit for SP23H Gunjet

SP23L76-18 (With 18" Extension) Brass, with Cap, less Tip
 SP23L76-24 (With 24" Extension) Brass, with Cap, less Tip
 SP23L76-36 (With 36" Extension) Brass, with Cap, less Tip

▲

SP30L-PP Gunjet 30 250psi with Cap, less Tip
 SP30L Gunjet 30 250psi with Cap, less Tip
 SP30LRK Repair Kit for Gunjet 30L
 SP30 Gunjet 30 700psi with Cap, less Tip
 SP30RK Repair Kit for Gunjet 30

SP30L-08 (With 8" Extension) Brass, with Cap, less Tip
 SP30L-18 (With 18" Extension) Brass, with Cap, less Tip
 SP30L-24 (With 24" Extension) Brass, with Cap, less Tip
 SP30L-36 (With 36" Extension) Brass, with Cap, less Tip

▲

SP31 Brass, with Cap, less Tip
 SP31RK Repair Kit for SP31 Gunjet
 SP8604-50 Inlet Strainer for No. 23L and No. 31 GunJet Spray Guns

▲

SP43L6 (low pressure) or SP43H6 (high pressure) Brass 43 Gunjet, with D6-Disc Tip
 SP43RK Repair Kit for SP43L Brass Gunjet
 SP43L6AL (low pressure) or SP43H6AL (high pressure) Aluminum 43 Gunjet, with D6-Disc Tip
 SP43ALRK Repair Kit for SP43L Aluminum Gunjet
 SP43LA6 (low pressure) or SP43HA6 (high pressure) Short Brass 43 Gunjet, with D6-Disc Tip
 SP43LA6AL Short Aluminum 43 Gunjet, with D6-Tip
 SPDX-HSS Tip for #43 GunJet, Hardened SS

SP46 Trigger Valve, Aluminum
 SP46RK Repair Kit for SP46 Trigger Valve

▲ Additional models and parts may be available. Call Spray Tech for price and availability.

GUNJET SPRAY GUNS AND ACCESSORIES

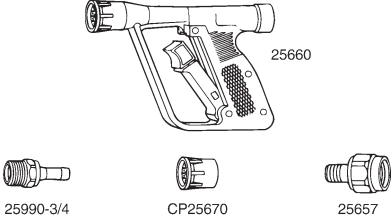
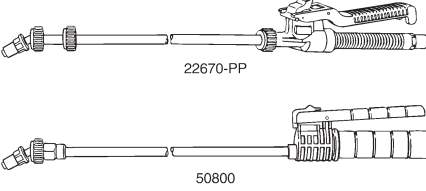
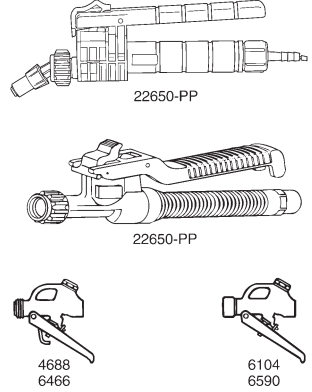
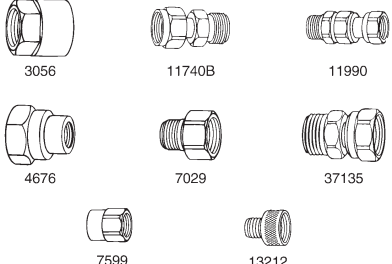
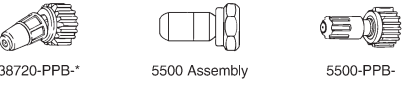
<p style="text-align: center;">TEEJET® LAWN SPRAY GUN</p>  <p style="text-align: center;">25660</p> <p>25990-3/4 CP25670 25657</p>	<p>SP25660-1.5, 3, or 4 TeeJet Lawn Spray Gun with Nozzle SP25660-0 TeeJet Lawn Spray Gun without Nozzle SP25670-1.5, 3, or 4 Nozzle for TeeJet Lawn Spray Gun SP25990-3/4 Hose Shank Swivel SP25657 Lawn Gun Adapter</p> <p>*Note: Extension No. 22665 can be found on page 153.</p>
<p style="text-align: center;">TRIGGERJET® SPRAY GUN WITH EXTENSION, STRAINER AND TIP</p>  <p style="text-align: center;">22670-PP</p> <p style="text-align: center;">50800</p>	<p>SP22670X18 TriggerJet with 15" Extension; Polypropylene SP22670-24 TriggerJet with 24" Extension; Polypropylene</p> <p>SP50800-3/8 3/8" Hose Barb, 21" Extension</p>
<p style="text-align: center;">TRIGGER VALVES</p>  <p style="text-align: center;">22650-PP</p> <p style="text-align: center;">22650-PP</p> <p style="text-align: center;">4688 6104 6466 6590</p>	<p>SP50800-38 TriggerJet Spray Gun, Polypropylene, 3/8"</p> <p>SP22650-14 TriggerJet Spray Gun, Polypropylene, 1/4" SP22650-406 TriggerJet Spray Gun, Polypropylene, 3/8"</p> <p>SP4688 Brass SP4688RK Repair Kit for 4688 SP6466 Brass, with Non-locking Trigger SP6466RK Repair Kit for 6466</p> <p>SP6104 Brass SP6104RK Repair Kit for 6104 SP6590 Brass, with Non-locking Trigger SP6590RK Repair Kit for 6590</p>
<p style="text-align: center;">SPRAY GUN ACCESSORIES</p>  <p>3056 11740B 11990</p> <p>4676 7029 37135</p> <p>7599 13212</p>	<p>SP3056 Garden Hose Adapter (for No. 46 Trigger Valve) SP4676-3/4" NPT (F) Outlet Adapter, Brass (for #12 GunJet Spray Guns) SP7029-GHT (F) x 1/2" NPT (M) Inlet Adapter w/Gasket brass (for #42 and #43 GunJet Spray Guns) SP7599-1/4-NP, -3/8-NP Inlet Adapter (for #23 GunJet, Brass) SP11740B 3/4" Garden Hose Swivel, Brass SP11990-6 1/4" NPS Swivel, Brass SP11990-18, -19 1/2" NPT (M) Swivel, Brass (for #43 and #143 GunJet Spray Guns) SP13212-3/8, -1/2 Garden Hose Adapter SP37135-1 Heavy Duty Swivel with 3/4" inlet, 1" outlet</p>
<p style="text-align: center;">ADJUSTABLE CONEJET® TIPS</p>  <p>38720-PPB-* 5500 Assembly 5500-PPB-</p>	<p>SP38720X(size), 8,12,18,26 Adjustable ConeJet Tip SP5500PX-(size) 5,6,8,12,18,22 Polypropylene SP5500-X(size) 1,2,3,4,5,6,8,10,12,18,22,26 Brass</p>

GUNJET SPRAY GUN ACCESSORIES

TRIGGER VALVE EXTENSIONS— Less tip, strainer and cap

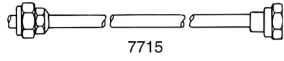

7715



4673

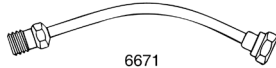

6671



9527

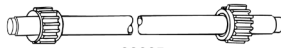

22665

SP7715-8 8" Straight Extension
 SP7715-18 18" Straight Extension
 SP7715-24 24" Straight Extension
 SP7715-30 30" Straight Extension
 SP7715-36 36" Straight Extension
 SP7715-48 48" Straight Extension

SP4673-8 8" Curved Extension with Adjustable Body
 SP4673-18 18" Curved Extension with Adjustable Body
 SP4673-24 24" Curved Extension with Adjustable Body
 SP4673-30 30" Curved Extension with Adjustable Body
 SP4673-36 36" Curved Extension with Adjustable Body
 SP4673-48 48" Curved Extension with Adjustable Body

SP6671-8 8" Curved Extension with Fixed Nozzle Body
 SP6671-18 18" Curved Extension with Fixed Nozzle Body
 SP6671-24 24" Curved Extension with Fixed Nozzle Body
 SP6671-30 30" Curved Extension with Fixed Nozzle Body
 SP6671-36 36" Curved Extension with Fixed Nozzle Body
 SP6671-48 48" Curved Extension with Fixed Nozzle Body



SP22665-15-PP TriggerJet Extension (15")
 SP22665-24-PP TriggerJet Extension (24")

SPRAY MONITORS



Spray Tech recommends and sells spray monitors by Redball and Wilger. Examples of the various styles are shown below:



Original Manifold Style	Squeeze Style	Modular Style
		

In most cases, Spray Tech part numbers can be derived by adding the prefix **'CA'** to the listed Redball part numbers. Add the prefix **'WI'** to the listed Wilger part numbers. Call Spray Tech if you have any questions when ordering.

Redball Spray Monitors

Manifold Style Monitors

Part No.	Description
CA3430-1	1/4" HB Manifold
CA3430-2	3/8" 90° HB Manifold

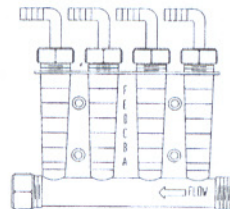

Squeeze Pump Style Monitors

Part No.	Description
CA3430-4	3/8" 90° HB 4 Column Squeeze
CA3430-5	1/2" 90° HB 4 Column Squeeze
CA3430-6	3/8" 90° HB 2 Column Squeeze
CA3430-7	1/2" 90° HB 2 Column Squeeze

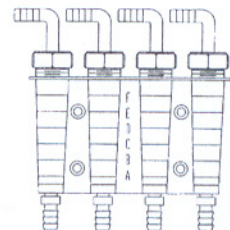

Replacement Parts for Manifold & Squeeze Pump Style

No.	Part No.	Description
1	8165300	4 Column Manifold Body
1	0101-3376	Body; 4col. 3/8" HB inlet Squeeze
1	0102-3376	Body; 2col. 3/8" HB inlet Squeeze
1	0103-3376	Body; 4col. 1/2" HB inlet Squeeze
1	0104-3376	Body; 2col. 1/2" HB inlet Squeeze
2	8165400	Washer; 3/4" EPDM (standard)
2	8165401	Washer; 3/4" Viton (optional)
3	8202100	Blank Disk
	8400-7	Monitor Clip
4	B35-M	Nut; Monitor; Poly
5	C12-EL	Elbow; 1/2" Hose Barb w/Tips
5	C12-M	Fitting; 1/2" Straight w/Tips
5	C38-EL	Elbow; 3/8" Hose Barb w/Tips
5	C38-M	Fitting; 3/8" Straight w/Tips
	8165200	Ball Stop (optional)
	8101900	Orifice Holder (optional)
	8202000	Orifice Holder (optional)

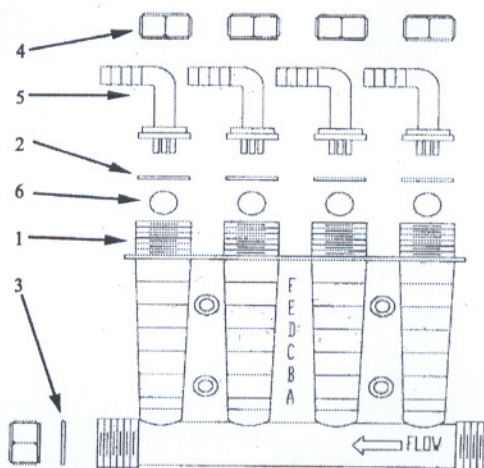

Replacement Monitor Balls

Part No.	Description
8165100	Red Plastic Ball
8165101	Green Plastic Ball
8165102	Black Plastic Ball
8165105	Red Glass Ball
SS316-200	Stainless Steel Ball (Order in quantities of 4)

Unless already listed above, add the prefix 'CA' to the Redball part numbers. Call Spray Tech if you have any questions when ordering.

Redball Spray Monitors

Modular Style Monitors

Purchase a 4 column box or build your own with our easy to setup starter and adder columns.
 Start with an adder column which includes the inlet and outlet hose barb and the end cap. Starter columns can also be used as a squeeze pump style monitor.
 The adder columns only come with the outlet hose barb.

Part No.	Description
CA3999-2	4 COL Monitor 3/8"
CA39993438	Starter Column 3/8"
CA3999-38	Add-on Column 3/8"

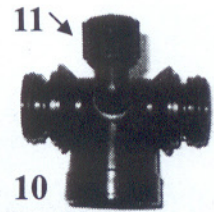
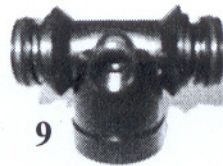
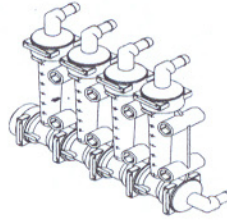

Replacement Parts for Modular Style

No.	Part No.	Description
1	002037	U-Pin
2	002133	1/4" Elbow Hose Barb; ORS
2	002134	3/8" Elbow Hose Barb; ORS
2	002135	1/2" Elbow Hose Barb; ORS
2	002136	3/4" Elbow Hose Barb; ORS
3	002137	Ball Stop
4	002138	Cap; Plug
5	002139	Column; Single; Modular Monitor
6	002140	O-ring; EPDM (standard)
6	002141	O-ring; Viton (optional)
8	20525	Tee; ORS x ORS x 1" FPT
9	007306	Adapter Fitting; ORS x 1/4" FPT
10	3F14	Tee; ORS M x ORS M x ORS F
11	3SE14	Tee; ORS x ORS x 1" FPT
	003930	ORS x ORS x 1" FPT with Gauge Port
	000418	Plug for Gauge
	000419	Street Elbow 1/4" for Gauge Port
		Monitor Clip; Modular Style Monitor
		Monitor Cross Bar
		Monitor Upright 30"

Replacement Monitor Balls

Part No.	Description
7 8165100	Red Plastic Ball
7 8165101	Green Plastic Ball
7 8165102	Black Plastic Ball
7 8165105	Red Glass Ball
7 SS316-200	Stainless Steel Ball

(Order in quantities of 4)

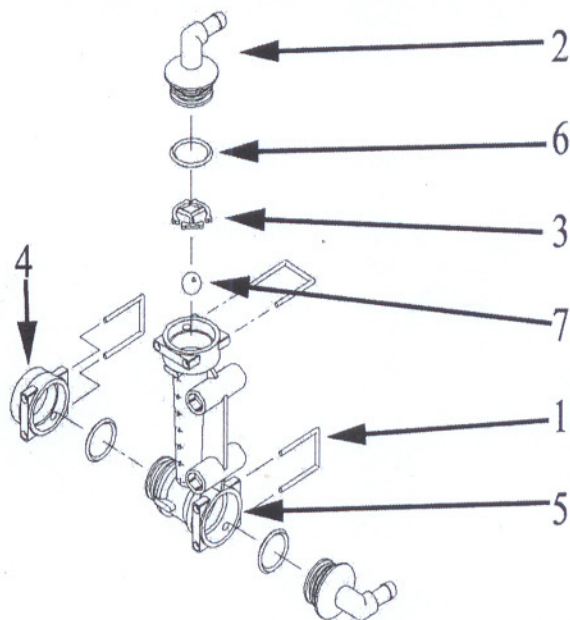

Unless already listed above, add the prefix 'CA' to the Redball part numbers. Call Spray Tech if you have any questions when ordering.



A liquid application innovation.

The Redball® Spray Monitor

The Redball® Spray Monitor is an effective flow indicator for an operator applying liquid chemicals and fertilizer. Once the monitor is set up, the operator observes the location of the balls. If there is no change in the ball location, then the flow rate has not changed. The amount of change needed for a ball to change can be found in the flow chart (Figure #2).

Installation Instructions

Mounting: Assemble and mount the monitor on your equipment in a position easily visible to the operator.

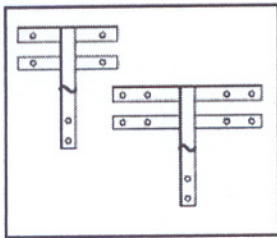

FIGURE #1

1. Fabricate a mounting bracket similar to the one in Figure #1. An example of typical material would be 3/4" x 1/8" steel strips and a 1" x 1" angle iron. Drill holes as shown and as needed to mount the bracket to the implement. Monitors should be connected in with center feed or multiple lines. Do not connect the monitors in series.
2. Check the flow tables (Figure #2) to see which balls are required for your desired rate of flow. For best results, pick out balls to be used so that they will operate at Level C or D of the Monitor.

FLOW TABLE FOR WATER					FLOW TABLE FOR LIQUID FERTILIZER				
	Green Plastic Balls GPM	Red Plastic Balls GPM	Red Glass Balls GPM	Steel Balls GPM		Black Plastic Balls GPM	Red Plastic Balls GPM	Red Glass Balls GPM	Steel Balls GPM
Level A	0-.03	0-.07	0-.13	0-.35	Level A	0-.02	0-.03	0-.09	0-.30
Level B	.03-.07	.07-.13	.13-.22	.35-.59	Level B	.02-.04	.03-.05	.09-.18	.30-.50
Level C	.07-.13	.13-.21	.22-.32	.59-.78	Level C	.04-.08	.05-.12	.18-.34	.50-1.20
Level D	.13-.16	.21-.29	.32-.43	.78-1.09	Level D	.08-.11	.12-.20	.34-.48	1.20-1.61
Level E	.16-.23	.29-.38	.43-.61	1.09-1.67	Level E	.11-.15	.20-.30	.48-.66	1.61-2.14
Level F	.23-UP	.38-UP	.61-UP	1.67-UP	Level F	.15-UP	.30-UP	.66-UP	2.14-UP

FIGURE #2

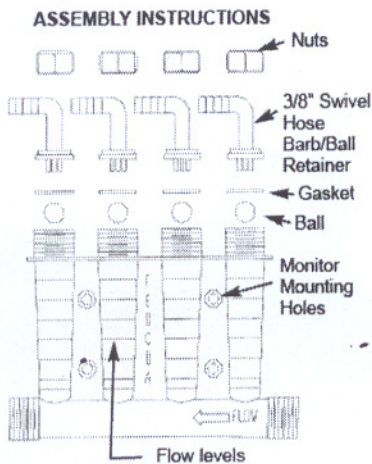

FIGURE #3

3. To change to a different set of balls, remove the nuts, the swivel hose barb/ball retainers, gaskets and balls and install the proper balls. See Figure #3.
4. Bolt the monitor to the bracket with 1/4" diameter bolts.
5. If one of the columns is not used, remove the hose barb and insert one of the discs.

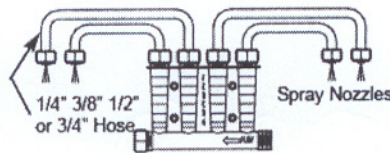

FIGURE #4

6. Insert the other disc in the cleaning nut.
7. Connect the hoses as shown in Figure #4. Tighten all nuts and hose connections.

Operating Instructions

1. Turn on liquid to the desired pressure, all the balls should be at the same level. If so, proceed to step #5.
2. If all the balls are not at equal levels, check for leaks and obstructions in the lines.
3. If one of the balls remains at a different level, clean the nozzle and screen on the line that has the improper output.
4. If all of the balls cannot be made to come up to the same level, check the flow in the lines to see if the flow is equal in all lines. The Redball® Spray Tip Tester may be purchased separately to evaluate this problem. This spray tip tester will also indicate if the tips are operating correctly.
5. When the balls are at the same level, then all the lines are putting out approximately equal amounts of liquid.
6. To calibrate your sprayer, first check the nozzle on the sprayer and the nozzle manufacturer's information sheet. Establish the correct pressure, flow, and speed to make sure that the desired gallons per acre will be applied.

Cleaning

It is important that spraying equipment is cleaned and flushed before discontinuing use for an extended period of time. To facilitate cleaning, remove the cleaning nut and allow the liquid to drain out. To flush, attach a hose directly to the hose barb. Flush with clean water.

Please Read

- **IMPORTANT:** When using different balls in fertilizer and water, it is important to use the correct ball, so as not to let it rotate at the very top of the monitor. The ball could restrict flow in that position.
- **IMPORTANT:** Use red glass or stainless steel balls with acid fertilizer.
- Conversion of the US gallons per minute to liters per minute is $G.P.M. \times 3.75 = L.P.M.$
- Each fluid used will vary in flow rate due to the different density and viscosity of each chemical and fertilizer used. This necessitates that the user checks for an accurate flow rate.
- The system should operate at a minimum of 10 PSI for equal distribution.
- Redball® Monitors are flow indicators, not flow regulators.

WILGER MODULAR SPRAY MONITORS

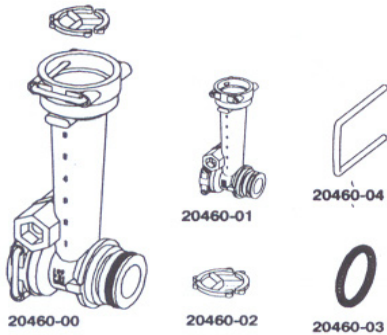

PART NO. with BUNA-N SEAL	PART NO. with VITON SEAL
20460-00	20460-V0
20460-01	-
20460-04	-
20460-02	-
20460-03	20460-15
40225-04	40225-05

FLOW INDICATOR ASSEMBLY and PARTS

FLOW INDICATOR ASSEMBLY (Includes Body, Ball Retainer, O-Ring Seal, two Lock U-Clips; and Black, Green, Red, and Stainless Steel Balls).....	
FLOW INDICATOR BODY.....	
LOCK U-CLIP, 302SS.....	
BALL RETAINER.....	
O-RING -#212 (For Indicator Body and Fittings).....	
O-RING -#015 (For Orifice Inserts).....	

FLOW INDICATOR O-RING SEAL FITTING ASSEMBLIES (Include required Seals and/or Lock U-Clips)

HOSE SHANK ADAPTERS

ORS x HOSE SHANK-STRAIGHT - 3/8".....	
ORS x HOSE SHANK-STRAIGHT - 1/2".....	
ORS x HOSE SHANK-STRAIGHT - 3/4".....	
ORS x HOSE SHANK-90 DEGREE - 3/8".....	
ORS x HOSE SHANK-90 DEGREE - 1/2".....	
ORS x HOSE SHANK-90 DEGREE - 3/4".....	

1/4" NPT FITTING ADAPTER

ORS MALE x 1/4" NPT FE.....	
-----------------------------	--

STREET ELBOW

ORS MALE x ORS FEMALE-90 DEGREE.....	
--------------------------------------	--

END CAP

ORS CAP	
---------------	--

CONNECTOR TEES

ORS MALE x ORS MALE X ORS FEMALE- TEE.....	
ORS MALE x ORS FEMALE(BLIND) X 3/8" NPT FE- ISOLATOR TEE	
ORS MALE x ORS MALE X 1" NPT FE- TEE.....	

FLOW METERING ORIFICE PLATES

ORIFICE INSERT ASSY-BLANK.....	
ORIFICE INSERT ASSY-0.025 Dia. Orifice.....	
ORIFICE INSERT ASSY-0.055 Dia. Orifice.....	
ORIFICE INSERT ASSY-0.104 Dia. Orifice.....	
ORIFICE INSERT ASSY-0.250 Dia. Orifice.....	

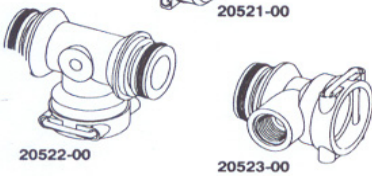

20501-00	20501-V0
20502-00	20502-V0
20503-00	20503-V0
20511-00	20511-V0
20512-00	20512-V0
20513-00	20513-V0
20519-00	20519-V0
20520-00	20520-V0
20521-00	20521-00
20522-00	20522-V0
20523-00	20523-V0
20525-00	20525-V0
21000-00	21000-V0
21025-00	21025-V0
21055-00	21055-V0
21104-00	21104-V0
21250-00	21250-V0

FLOW RATE

PER COLUMN

US GPM(water)

20460-09	0.03-0.09
20460-08	0.05-0.18
20460-07	0.09-0.30
20460-06	0.31-0.72
20460-05	0.40-1.33
20460-10	1.00-2.70

FLOW INDICATION BALLS

BALL - FLOW INDICATOR-BLACK POLYPROP.....	
BALL - FLOW INDICATOR-GREEN POLYPROP.....	
BALL - FLOW INDICATOR-RED CELCON.....	
BALL - FLOW INDICATOR- BLUE GLASS.....	
BALL - FLOW INDICATOR-1/2" STAINLESS STEEL 302.....	
BALL - FLOW INDICATOR-7/16" STAINLESS STEEL 302.....	

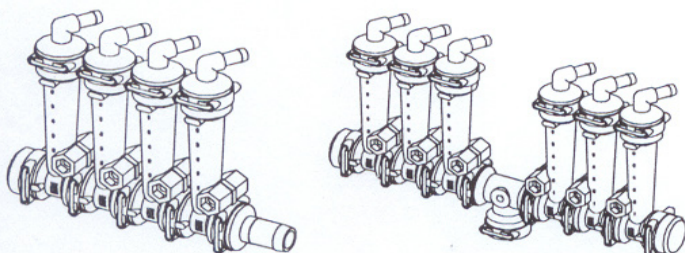
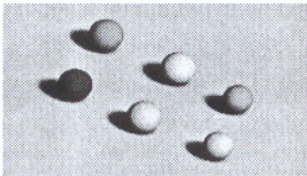

To derive the correct Spray Tech part numbers, add the prefix 'WI' to the listed Wilger part numbers. Call Spray Tech if you have any questions when ordering.

HOSE

EPDM RUBBER SPRAY HOSE (BLACK)



BULK HOSE

Part No.	Inside Diameter	Reel Qty	Spiral	Pressure
GY025X2SP	¼"	500'	2	200#
GY038X2SP	⅜"	500'	2	200#
GY050X2SP	½"	500'	2	200#
GY058X2SP	⅝"	500'	2	200#
GY075X2SP	¾"	500'	2	200#
GY100X2SP	1"	450'	2	200#
GY025X4SP	¼"	500'	4	250#
GY038X4SP	⅜"	500'	4	250#
GY050X4SP	½"	500'	4	250#
GY058X4SP	⅝"	500'	4	250#
GY075X4SP	¾"	500'	4	250#
GY100X4SP	1"	450'	4	250#
GY125X4SP	1 ¼"	300'	4	150#
GY150X4SP	1 ½"	300'	4	150#
GY200X4SP	2"	200'	4	150#

Hose orders of less than reel quantity are subject to a 10% surcharge.

Applications: Versatile general purpose hose, which is excellent for air and water service as well as many agricultural chemicals including LASSO® herbicide. The EPDM tube and cover resists heat, sunlight, ozone and weathering. Exceeds RMA class C medium oil resistance requirements. Suitable for applications such as oil mist lubricating air lines, but NOT suitable for the transfer of petroleum products.

Construction: Closely plied reinforcement of 2 or 4 spiral high tensile textile cord provides excellent coupling retention and kink resistance.

Fittings: Universal quick couplings, long or short shank, insert type, reusable.

Note: 85% of ¼"-1" reels come in a single 500' length. The reels may have up to 3 pieces, the minimum length of any one piece is 50'.

WARNING: Not for use with anhydrous ammonia.

UPS-able Black Spray Hose*			
Part Number	Inside Diameter	Length	Approximate Weight
GOUPS038	⅜"	400'	60#
GOUPS050	½"	250'	60#
GOUPS058	⅝"	225'	65#
GOUPS075	¾"	150'	55#
GOUPS100	1"	125'	55#

*UPS-able hose reels are priced by the reel instead of by the foot.

FERTILIZER SOLUTION SUCTION / DISCHARGE HOSE

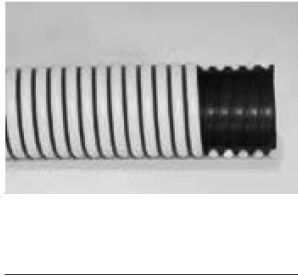

BULK HOSE

EPDM RUBBER w/POLYETHYLENE HELIX (may be yellow, green, or gray in color)

Reel Quantity: 100' Hose orders of less than reel quantity are subject to a 10% surcharge.

Part Number	Inside Diameter	Working Pressure
GOEPDM100	1"	80#
GOEPDM125	1 ¼"	70#
GOEPDM150	1 ½"	60#
GOEPDM200	2"	60#
GOEPDM300	3"	50#
GOEPDM400	4"	45#

REINFORCED FERTILIZER SOLUTION HOSE



BULK HOSE

Reel Quantity: 100' Hose orders of less than reel quantity are subject to a 10% surcharge.

Part Number	Inside Diameter	Working Pressure
GO125S-D	1 ¼"	100#
GO150S-D	1 ½"	100#
GO200S-D	2"	100#

Applications: A reinforced, flexible suction / discharge hose for the agricultural and construction industries. Hose is resistant to diluted herbicides and pesticides with good flexibility in sub-zero weather.

Construction: EPDM tube with polyethylene helix and a high tensile fabric reinforcement.

Temp. Range: -30°F to 140°F.

EPDM RUBBER SUCTION HOSE (WIRE-REINFORCED SUCTION HOSE)



BULK HOSE

Reel Quantity: 100' Hose orders of less than reel quantity are subject to a 10% surcharge.

Part Number	Inside Diameter	Working Pressure
GOWIR100	1"	150#
GOWIR125	1 ¼"	150#
GOWIR150	1 ½"	150#
GOWIR200	2"	120#
GOWIR300	3"	85#
GOWIR400	4"	75#

PVC WATER SUCTION HOSE



BULK HOSE

Reel quantity: 100' Hose orders of less than reel quantity are subject to a 10% surcharge.

Part Number	Inside Diameter	Working Pressure
GOPVC100	1"	100#
GOPVC125	1 ¼"	90#
GOPVC150	1 ½"	70#
GOPVC200	2"	60#
GOPVC300	3"	50#
GOPVC400	4"	45#

Applications: A PVC suction / discharge hose for water, light chemicals, and pumping service in the agricultural, rental, construction, marine, and irrigation industries. **Construction:** A smooth bore hose made of flexible abrasion resistant extruded clear PVC with a rigid PVC helix. **Temp. Range:** -10°F to 130°F (under static conditions).

PVC LAY FLAT DISCHARGE HOSE (BLUE)



BULK HOSE

Reel quantity: 300' Hose orders of less than reel quantity are subject to a 10% surcharge.

Part Number	Inside Diameter	Working Pressure
GOLDH125	1 ¼"	80#
GOLDH150	1 ½"	75#
GOLDH200	2"	70#
GOLDH300	3"	55#
GOLDH400	4"	45#

MILL WASH DOWN / DISCHARGE HOSE



BULK HOSE

Reel quantity: 100' Hose orders of less than reel quantity are subject to a 10% surcharge.

Part Number	Inside Diameter	Working Pressure
GOMIL150	1 ½"	250#
GOMIL200	2"	250#

TUBING

NON-REINFORCED EVA TUBING



BULK HOSE

Hose orders of less than reel quantity are subject to a 10% surcharge.

Part Number	Inside Diameter	Reel Length
GOEVA025	1/4"	500'
GOEVA050	1/2"	500'
GOEVA058	5/8"	250'
GOEVA075	3/4"	250'
GOEVA100	1"	200'
GOEVA125	1 1/4"	100'

Applications: Used in agricultural, lawn, and chemical transfer. Handles common herbicides and insecticide solutions, including Monsanto's Lasso®. Used for the application of anhydrous ammonia, aqua ammonia, phosphates, and all liquid fertilizers.

Construction: Ethyl vinyl acetate plastic tubing.

Temp. Range: For natural eva tubing -50°F to 125°F.

Features: Good chemical / weather resistance. Black tubing has a higher ozone resistance than standard eva tubing.

WARNING: Not for transfer of anhydrous ammonia under pressure. Recommended for open-end discharge only.

REINFORCED EVA TUBING



BULK HOSE

Hose orders of less than reel quantity are subject to a 10% surcharge.

Part Number	Inside Diameter	Reel Length
GONREVA025	1/4"	300'
GONREVA050	1/2"	300'
GONREVA075	3/4"	300'
GONREVA100	1"	200'

Applications: Used in agricultural, lawn, and chemical transfer. Handles common herbicides and insecticide solutions, including Monsanto's Lasso®. Used for the application of anhydrous ammonia, aqua ammonia, herbicides, phosphates, and all liquid fertilizers.

Construction: Ethyl vinyl acetate plastic tubing with polyester textile yarn reinforcement.

Features: Good chemical and weather resistance. Solid black coloring of this tubing cover provides better UV and ozone resistance than the standard natural colored tubing.

WARNING: Not for transfer of anhydrous ammonia under pressure. Recommended for open-end discharge only.

NON-REINFORCED CLEAR VINYL TUBING (Sight-gauge Hose)**Boxed Bulk Hose**

Hose orders of less than reel quantity are subject to a 10% surcharge.

Part Number	Inside Diameter	Reel Length	Working Pressure
GOCLR025	1/4"	100'	50
GOCLR038	3/8"	100'	40
GOCLR050	1/2"	100'	25
GOCLR050H	1/2" heavy wall	100'	45
GOCLR058	5/8"	100'	40
GOCLR075	3/4"	100'	35
GOCLR100	1"	100'	25
GOCLR125	1 1/4"	50'	40
GOCLR150	1 1/2"	50'	35

Applications: Ideal for liquids and also used as sight gauge on storage tanks. **Construction:** Polyvinyl chloride. **Features:** A clear, flexible, and lightweight tubing that provides full-flow viewing. **Benefits:** Good to excellent resistance to acids, fair to excellent resistance to alkalies, and excellent resistance to most solvents, except ketones, esters, and some aromatic hydrocarbons.

DUCTING

Call Spray Tech for price and availability of the various styles of ducting hose.

TEEJET GUIDANCE

TeeJet® CenterLine 220

Compact Guidance for any Application

The compact CenterLine 220 is designed to let you profit from GPS lightbar guidance with any field operation. Inside the compact guidance system is a high-quality WAAS/EGNOS GPS receiver and the guidance capabilities that make TeeJet leaders in lightbar guidance.

- Versatile GPS guidance in a compact, portable package.
- LED Lightbar guidance plus a graphical display for complete guidance information.
- High-quality, 5 Hz internal GPS engine with external antenna.
- Simple setup gets you up and running in no time.
- Straight-line (parallel) and curved AB guidance modes.
- Integrated look-ahead functionality anticipates vehicle's future position.
- Return-to-point feature.
- Durable, sealed rubber keypad is easy to see and provides good tactile feedback.
- Provides RADAR-like speed signal output for use with other control systems that require a ground speed signal.



Working Page Layout

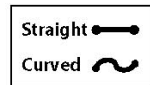

Guidance Mode

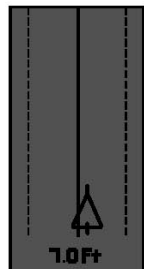

View Page
Straight AB



View Page
Curved AB

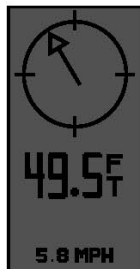

View Page
Return-to-Point



Set Swath
Width Screen

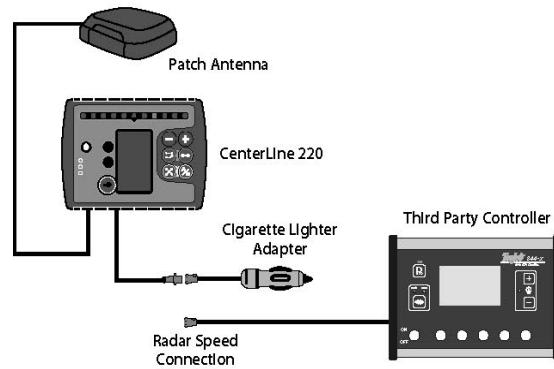

How to Order

PART NUMBER	DESCRIPTION
90-02340	CenterLine 220 Kit, US Version

90-02342	CenterLine 220 Kit, EGNOS
----------	---------------------------

ACCESSORIES

78-50155	Patch Antenna
90-02349	RAM Mount Kit for CenterLine 220

In most cases, to derive the Spray Tech part number, add the prefix 'MT' to the above listed TeeJet Guidance products.

TeeJet® CenterLine™

Lightbar Guidance System with Wireless Remote Control

- Compact lightbar with fully adjustable brightness for day or night operation.
- Convenient wireless remote controls lightbar functions — even if the lightbar is mounted outside.
- The foundation of your GPS guidance system.



Effective Guidance

Lightbar Guidance System with Wireless Remote Control

CenterLine offers the most features, the best price and wireless convenience in one complete kit. This compact lightbar guidance system is available with a WAAS/EGNOS DGPS receiver/antenna and includes a wireless remote control.

Guidance that Works the Way You Do

Choose from parallel, headland (contour) or curved AB modes. CenterLine automatically gives you guidance information to the closest swath and counts down the distance to the next swath as you turn at row ends.

Shows You the Information You Want

A bright text display reports the application information of your choice automatically. It also warns you when you enter an area of the field that has already been applied. Data you can monitor includes:

- Current position error from active swath
- Current swath number
- Vehicle speed
- Area that's been applied
- Course relative to 360° position

Mapping and Data Collection

When used with the Smartpad II handheld computer, the CenterLine system can map field boundaries, field hazards and application records. And you can view progress on-screen as you work.

Upgradable to Meet Your Needs

CenterLine is upgradable to match your changing guidance needs. CenterLine is fully compatible with Swath Manager automatic boom section control as well as the Tilt Compensation Module.

Smartpad II

See Where You've Missed

Maps are viewed as you make them so skips can be seen and fixed before leaving the field.

Built to Last

Durable housing is designed to withstand the rigors of field work.

Keep a Permanent Record

Smartpad II uses compact flash data cards and saves all field records. Download these to your office computer for a permanent record.

High-Resolution Display

76 mm x 50 mm (3" x 2") high-resolution color touch screen display is easy to view in any lighting.



In most cases, to derive the Spray Tech part number, add the prefix 'MT' to the above listed TeeJet Guidance products.

TeeJet CenterLine™

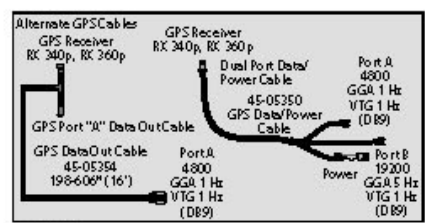
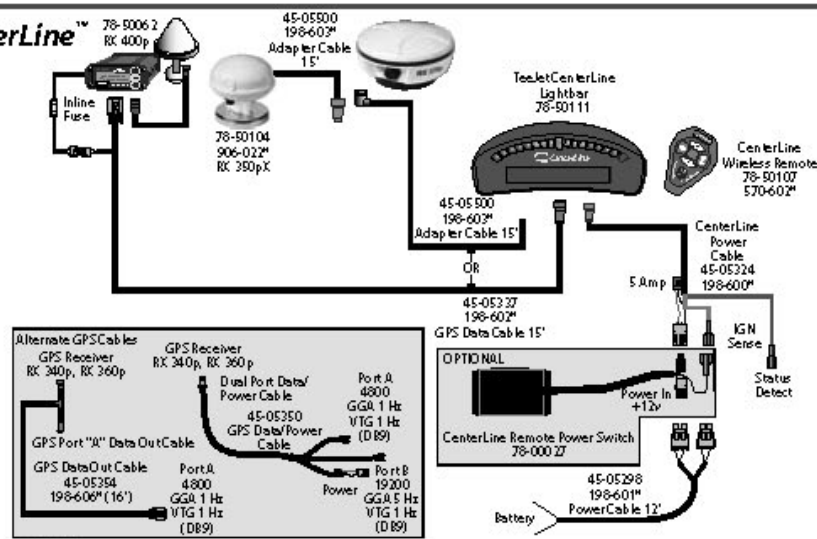

* LHPart Number

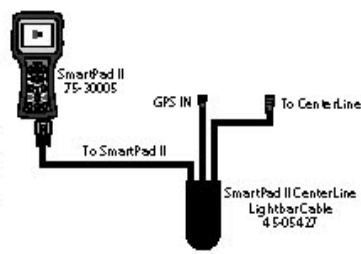
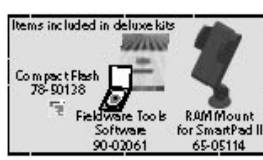

Spare Parts and Accessories

PART NUMBER	DESCRIPTION
45-05298	Battery Cable—12'
45-05324	CenterLine Power Cable—12'
45-05337	CenterLine Power/Data Cable (Packard/DB9)—15'
45-05338	GPS Data Cable w/12 pos. DT
45-05340	Deutsch to DB9 and Power
45-05343	Extension Cable—CenterLine to GPS Data Cable—10'
45-05350	GPS Data Cable with dual DB9 and Power—16'
45-05354	GPS Data Cable with single DB9—16'
45-05427	CenterLine to SmartPad II Harness
64-05066	Suction Cup Mount
65-05114	Smart Pad II RAM Mount
65-05052	CenterLine Lightbar Bracket
78-00027	Remote Power Switch
78-50150	RX 340p GPS Receiver
78-50062	RX 400p GPS Receiver
78-50148	RX 370p GPS WAAS Receiver
78-50152	RX 370p GPS Receiver (Autonomous)
78-50153	RX 370p GPS Receiver (EGNOS 120,126)
78-50154	RX 370p GPS Receiver (e-dif)
78-50151	RX 500 GPS Receiver
78-50094	CenterLine Wireless Remote (418 Mhz—Black Enclosure)
78-50096	TeeJet CenterLine Lightbar (418 Mhz—Black Enclosure)
78-50107	CenterLine Wireless Remote (433 Mhz—Gray Enclosure)
78-50111	TeeJet CenterLine Lightbar (433 Mhz—Gray Enclosure)
78-50138	Compact Flash Card, 128MB
90-02061	Fieldware Tools ver 3.00
98-01094	CenterLine Quick Start Guide—English
98-05054	CenterLine User Guide—English

How to Order

PART NUMBER	DESCRIPTION
90-02185	TeeJet CenterLine Basic System (no GPS Receiver)
90-02379	TeeJet CenterLine System with RX340p GPS Receiver
90-02186	TeeJet CenterLine System with RX370p GPS Receiver
90-02187	TeeJet CenterLine System with RX400p GPS Receiver
90-02223	TeeJet CenterLine System with RX370p e-dif (Portuguese)
90-02278	TeeJet CenterLine System with RX370p e-dif (Spanish)
90-02350	TeeJet CenterLine System with RX370p (autonomous)
90-02380	CenterLine with SmartPad II Basic and RX340p
90-02292	CenterLine with SmartPad II Basic and RX370p
90-02381	CenterLine with SmartPad II Deluxe and RX340p
90-02296	CenterLine with SmartPad II Deluxe and RX370p
90-02351	CenterLine with SmartPad II Basic and RX370p (autonomous)
90-02278	Smartpad II Deluxe Upgrade Kit for CenterLine
90-02290	Smartpad II Basic Upgrade Kit for CenterLine
75-30005	Smartpad II Handheld Computer

In most cases, to derive the Spray Tech part number, add the prefix 'MT' to the above listed Teejet Guidance products.

Tilt Compensation Module

If your GPS antenna is mounted 12 feet (4 meters) above the ground, a 10% side slope can cause 2 feet (.6m) of position error. The new Tilt Compensation Module corrects GPS position errors caused by side-slope conditions. Mounted to a solid structure on your vehicle, the Tilt Compensation Module will intercept GPS signals from your receiver and provide corrected position data to your guidance device.

- Diagnostic LEDs indicate status of TCM (power status, operating status, and status of incoming GPS data).
- Weatherproof electrical connector for trouble-free operation.
- Mounting holes built into housing.
- Automatically detects GPS sensor baud rate and adjusts output accordingly.
- Compatible with Swath XL, GuideLine, CenterLine, and Legacy 6000 guidance systems.

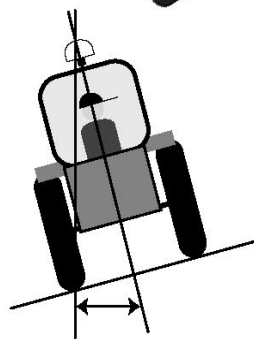
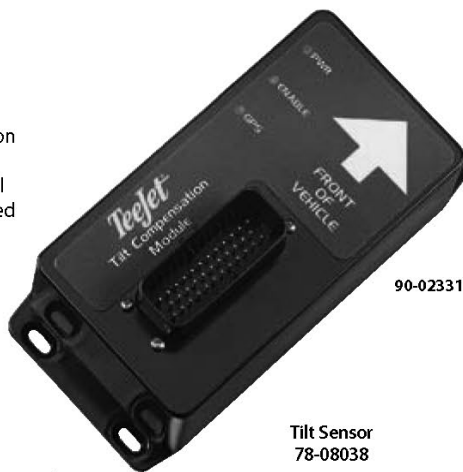

Tilt Sensor
78-08038

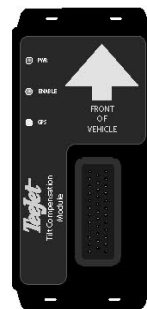

CenterLine
Tilt Sensor Cable
45-05442

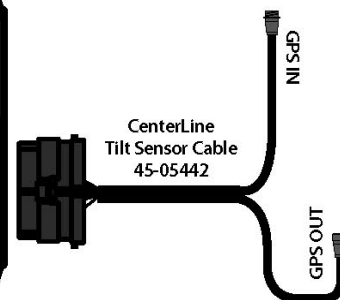

How to Order

PART NUMBER	DESCRIPTION
90-02331	Tilt Compensation Module Kit for Guidance Systems
90-02332	Tilt Compensation Module Kit for Legacy 6000
45-05442	Cable, Tilt Compensation, Corxall
45-05441	Cable, Tilt Compensation, DB9
78-08038	Module, Tilt Compensation

Swath Manager 5

Add the Swath Manager 5 to your CenterLine lightbar and get automatic boom section control of up to five boom sections. The CenterLine and Swath Manager 5 store information about where you have sprayed. When you overlap these areas, the corresponding boom sections are switched off. The Swath Manager can interface to your existing spray rate controller to ensure accurate application rates and area accumulation.



How to Order

PART NUMBER	DESCRIPTION
90-02344	Swath Manager 5 Basic, CenterLine to 844/854
90-02345	Swath Manager 5 Basic, CenterLine to ARC/TASC
90-02346	Swath Manager 5 Basic, CenterLine to Raven 440
90-02385	Swath Manager 10 Kit

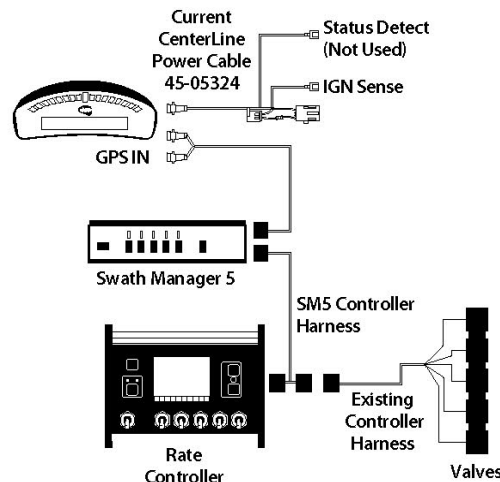

In most cases, to derive the Spray Tech part number, add the prefix 'MT' to the above listed TeeJet Guidance products.

TeeJet® GPS Receivers

TeeJet offers a full range of high-quality GPS receivers to fit your precision farming needs. Economical WAAS and EGNOS 'smart antennas' are convenient and affordable. Other receivers provide more differential correction options for maximum flexibility.



GPS Antenna

RX 400p

- Flexible receiver is compatible with WAAS/EGNOS, Coast Guard Beacon, and L-band corrections.
- Cruise technology keeps running even during brief differential signal losses.
- Setup wizard guides user through setup process.
- On-board display and buttons permit easy configuration and status checks.
- Separate antenna is compatible with GPS, WAAS, Beacon, and L-band signals.



RX 340p

- Antenna and receiver housed in one permanently sealed package.
- Compatible with free WAAS and EGNOS correction signals.
- 5 Hz position update rate makes this receiver fully compatible with manual and automatic lightbar guidance systems.
- Pre-configured for plug-and-play compatibility with TeeJet guidance systems.



RX 370p

- New design incorporates antenna and receiver in one permanently sealed package.
- Compatible with free WAAS and EGNOS correction signals.
- Produces a radar-like speed signal output compatible with many control and monitor systems.
- Cruise technology maintains accuracy during brief correction signal outages.
- Up to 10 Hz position update rate makes this receiver fully compatible with manual and automatic lightbar guidance systems.
- Pre-configured for plug-and-play compatibility with TeeJet guidance systems.
- CAN NMEA 2000 output.



RX 500

- Sub-meter performance with free WAAS or EGNOS corrections.
- Decimeter (2"-4" pass-to-pass) accuracy with Omnistar HP or XP subscription.
- Precision antenna mounted remotely from receiver unit.
- Five Hz update rate standard. User-configurable for up to 20 Hz update rate. (Upgrade fee may apply).
- Three serial RS232 ports and one USB I/O port.

How to Order

PART NUMBER	DESCRIPTION	(WAAS/EGNOS) (SUB-METER)	OMNISTAR VBS (SUB-METER)	BEACON (SUB-METER)	OMNISTAR HP/XP (DECIMETER)	E-DIF (METER +)
78-50150	RX340p	Yes				
78-50148	RX370p Standard WAAS	Yes				Yes
78-50152	RX370p Autonomous					
78-50153	RX370p EGNOS 120,126	Yes				
78-50154	RX370p e-Dif					Yes
78-50062	RX400p	Yes	Yes	Yes		Yes
78-50151	RX500	Yes	Yes		Yes	

In most cases, to derive the Spray Tech part number, add the prefix 'MT' to the above listed TeeJet Guidance products.

RAVEN GUIDANCE

Envizio is Raven's latest Precision Guidance System. Combining lightbar LED's with a 3D color touch screen, the Envizio offers a new compact hardware design, loaded with powerful software capabilities. The Envizio can be used as a stand-alone guidance system, or as an interface to existing Raven lightbars.



Envizio's Guidance features include the new LastPass Guidance pattern. This Guidance pattern allows the user to always drive based on last pass. LastPass guidance allows operators to come back to a job and guide off the same line as the previous job. LastPass makes it simple to show where you have been and reduces the spot skips and overlaps.

Part No.	Description
RA117-012	Envizio guidance system (core kit only)
RA117-836	VIPER guidance system (core kit only)
ACCESSORIES	
RA117-843	Invicta antenna
RA117-071	Phoenix antenna
Call Spray Tech for more information on all the components necessary to build a Raven guidance system that meets your specific needs.	

RICHWAY

FOAM MARKERS AND ACCESSORIES



GOODMARK FOAM		
	RIFOAM-G	Goodmark Foam, 1 Gallon Long-lasting foam, even in hot weather conditions!
FOAM DYES		
	BUFDLU BUFDRED BUFDYEL BUORED BUSDRC	Pint Blue Foam Dye Pint Red Foam Dye Pint Yellow Foam Dye Pint Red Oil Foam Dye Dye- Red Concentrate

RICHWAY FOAM MARKERS		
	Part No.	Description
BoomTracker 	Call	Makes the foam out at the ends of the boom; several tank sizes available- Call Spray Tech for price and availability.
Trac Master	Call	Makes the foam at the center of the boom, then pushes it out to the ends; several tank sizes available- Call Spray Tech for price and availability.
Collector Heads	RICH150NO RICH200NO RIS4-19 RIK0013 RIS4-17	1 1/2" barb, neon orange collector head. 2" barb, neon orange collector head. Collector cartridge for Richway Collector Heads. 1 1/2" drop hose. 2" drop hose.
Compressors	RIK-0024 RIS1-21	Small diaphragm compressor Large rotary-vane compressor
The complete list of Richway parts and accessories is available in the current Spray Tech Price list; each part number begins with 'RI'.		







TURF TRACKER

Call Spray Tech for more information on the Turf Tracker, a small foam marker system for lawn, garden, and golf course applications.

RATE CONTROLS

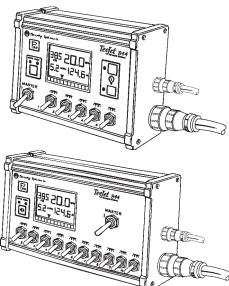
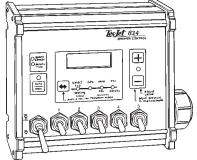
TEEJET ELECTRONIC SPRAYER CONTROLS



In most cases, core kits listed on this page do not include all components necessary for a working control system. See individual core kit descriptions for details.

	<p>MT90-02108 MT75-50001</p>	<p>854 Core Kit (console with mounting brackets, cables and manual) 854 Console</p>
<p>844-E SPRAYER CONTROLS</p> 	<p>MT90-50017 MT75-50011 MT75-50006</p>	<p>844-E-5 Core Kit (console with mounting brackets, cables, and manual) 844-E-5 Console Only 844-E-5 Console with Foam Marker Switch</p>
<p>834 SPRAYER CONTROL</p> 	<p>MT90-50014 MT75-50004 MT90-50015 MT75-50005 MT90-50016 MT75-50018</p>	<p>834-5 Core Kit (US Units, includes console, mounting brackets, cables, pressure sensor and manual) 834-5 Console Only (US Units) 834-5 Core Kit (Metric units, includes console, mounting brackets, cables, pressure sensor and manual) 834-5 Console Only (Metric Units) 834-RA Core Kit (roadway applications) 834-RA Console Only</p>
<p>RAVEN Flow Controls</p>		
	<p>RA063-183 RA106-437</p>	<p>Raven 440 Console only 440 Console bracket</p>
	<p>RA063-125 RA063-001</p>	<p>1" Control Valve (pictured) 3/4" Control Valve</p>
	<p>RA063-793 RA063-040 RA117-569 RA115-016</p>	<p>RFM 60 Flowmeter, Flanged & Threaded (pictured) RFM 15 Flowmeter, Flanged RFM 60 Flowmeter Transducer 6' Flowmeter Cable</p>

RAVEN Flow Controls (continued)

Speed Sensor Cables	RA115-517 RA115-526 RA115-700 RA115-032	Speed sensor cable for Case IH Speed sensor cable for Dickey-John Speed sensor cable for John Deere 12' Radar ext cable
Flowmeter Cables	RA115-404	6' Flowmeter cable
Console Cables	RA115-418	10' Console cable
Additional Automatic Flow Controls parts are available- Call Spray Tech with any questions.		

GPS Speed Sensors for Teejet and Raven Flow Controls

<p>TEEJET Technologies</p> 	<p>MT90-02371 MT90-02386 MT90-02404</p>	<p>GPS Speed Sensor for MidTech/Generic/DJ GPS Speed Sensor for Teejet Controls GPS Speed Sensor for Raven Controls</p>	<p>TeeJet Technologies' GPS Speed Sensor is compact, easy to use, and is quickly installed on your vehicle. The 5 Hz update rate ensures smooth signal output.</p> <p>The antenna must be mounted in a location where it will have an unobstructed view of the sky. The Speed Sensor is mounted inside the cab of the vehicle. Connect the antenna to the Speed Sensor, the 4-pin AMP connector to your control equipment, and you're off! It's that simple!</p> <p>TeeJet Technologies' GPS Speed Sensor is preprogrammed and starts instantly - there is no calibration necessary. Even upon initial power-up of the GPS Speed Sensor, the GPS Speed Sensor takes less than one minute to establish a satellite lock.</p> <p>TeeJet Technologies' GPS Speed Sensor is compatible with most devices using RADAR ground speed. Adapter cables are available.</p>
<p>Squibb-Taylor Sky-Trak</p> 	<p>MISK1007D MISK1007R</p>	<p>GPS Speed Sensor with Dickey-John/Generic connection GPS Speed Sensor with Raven connection</p>	<ul style="list-style-type: none"> • Completely self-contained (GPS, receiver, antenna, and velocity to pulses converter) • 16 Channel GPS receiver • Can be used with all equipment that is compatible with radar or pulse type speed sensors • 0.1 MPH accuracy from 0.5 to 50 MPH • Surface, bracket, pipe, or magnetic mount • UV stable, plastic enclosure • 7 updates per second

TEEJET CONTROLLER CABLES

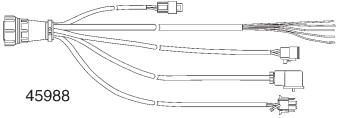
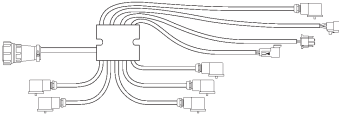
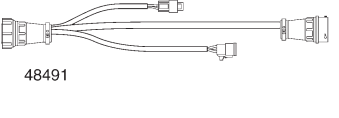
DIRECT CABLES			
 <p>45988</p>	For 854 Console:		
	MT45-05210	NA	Direct Cable for 854, 26', 5 section
	For 834, 844 Consoles:		
 <p>48490</p>	MT45-20065	45988	Direct Cable, 26', 5 section
	MT45-20066	45988-1	Direct Cable, 14', 5 section
	MT45-20000	48490	JunctionBlox Cable, no power connection, 21' valve cables, 5 section
 <p>48491</p>	MT45-20072	48589	JunctionBox Cable, no power con, 6' valve cables, 5 section
	MT78-05043	NA	Direct Cable, 10', 10 section
	MT45-10046	NA	Direct Cable, 10', 17' speed lead, 5 section
Extension cables for 834, 844, 854 consoles:			
	MT45-20239	48491	SprayLink Ext. w/power and speed leads, 10', 5 section
	MT45-20243	NA	SprayLink Ext. w/power (ring terminals), 15', 5 section
	MT45-10050	NA	SprayLink Ext. w/power (ring terminals), 10', 10 section
	MT45-20237	48297-S5-3	SprayLink Ext. 10', 5 section
	MT45-20240	48297-S5-4	SprayLink Ext. 13', 5 section
	MT45-20242	48297-S5-7	SprayLink Ext. 23', 5 section
	MT45-20238	48297-S5-10	SprayLink Ext. 33', 5 section
	MT45-20241	48297-S13-3	SprayLink Ext. 10', 10 section
General Purpose cables for all consoles:			
	MT45-20009	38403-12-COMMAT	Power Cable, 12'
	MT45-20017	39035	Wheel Speed Extension Cable, 15'
	MT45-20084	39039-1	"Y" Adapter Cable-D-j Cable Splitter
	MT45-20025	39039-2	"Y" Adapter Cable-D-j or Magnavox (JD)
	MT45-20026	39039-3	"Y" Adapter Cable-D-j (CASE/H)
	MT45-20027	39039-4	"Y" Adapter Cable-D-j or Magnavox (JD7000/8000)
	MT45-20028	39039-5	"Y" Adapter Cable-D-j (Cat 65C/75C)
	MT45-20029	39039-6	"Y" Adapter Cable-D-j (CAT 65/75)
	MT45-20030	39039-7	"Y" Adapter Cable-D-j (Ford/White)
	MT45-20031	39039-8	"Y" Adapter Cable-D-j (Ford Genesis)
	MT45-20040	39499	Radar Adapter Cable (Magnavox), 12"
	MT45-20041	39499-1	Radar Adapter Cable (Magnavox), 15"
	MT45-20042	39512	Radar Adapter Cable (Dickey-john), 12"
	MT45-20043	39513	Radar Adapter Cable (Raven), 12"
	MT45-20044	39514	Adapter Cable (Micro-Trak Trak Star), 12"
	MT45-20032	39460-1	Convenience Power Cable for John Deere 6'
	MT45-20033	39460-2	Convenience Power Cable for Case/IH 6'

TEEJET SPEED SENSORS AND REGULATING VALVES

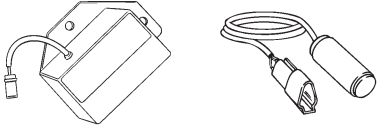
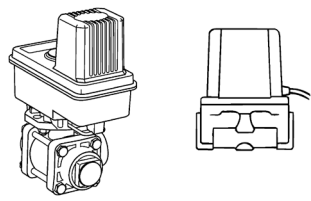
SPEED SENSORS			
	MT16-40004	38412-1	Proximity Speed Sensor
	MT16-40007	38525-1	Wheel Speed Sensor Kit (sensor, 2 magnets & brkts)
	MT16-40012	38525-COMMAT	Wheel Speed Sensor Kit (sensor, 4 magnets & brkts)
	MT16-40003	38412	Wheel Speed Sensor only
	MT64-50014	38416	Single Magnet Assembly
	MT16-40013	38531-IZP	Speed Sensor Bracket Assembly
	MT78-50082	NA	Compact II Radar Speed Sensor
	MT90-02169	NA	Compact II Radar Kit
	Regulating valves for SprayLink direct-cabled systems		
	MT35-02099	NA	Ball Valve, 1" NPT B-series Poly ball, 6 sec
	MT35-02112	NA	Ball Valve, 50 Series flange w/ B series motor, 6 sec
	MT35-50029	21773-244C-3/4	Butterfly Valve, 3/4" NPT 244C, 20 sec
	MT35-02090	NA	Butterfly Valve, 1 1/2" NPT B-series, 6 sec
	MT35-02089	NA	Low-flow Valve, 1" NPT B-series Poly ball, 18 sec

TEEJET SPRAYER CONTROL ACCESSORIES

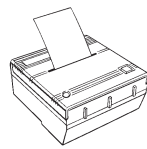
ACCESSORIES			
	MT65-50004	38528	Console Mounting Bracket
	MT78-20002	45970	Printer, Alphapanel
	MT45-20063	45984-15	SprayLink Communication Cable
	MT45-20064	45987	SprayLink Communication Cable with Power

TEEJET FLOW METERS

FLOW METERS AND ACCESSORIES

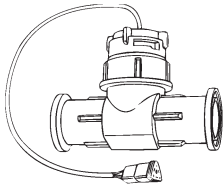
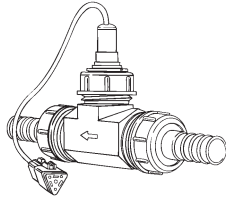
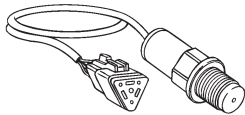
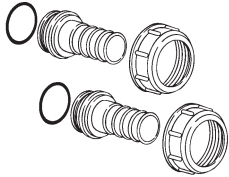
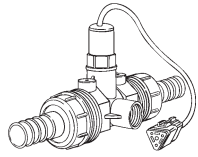

* Also available in Graphite Bearings (-GR)

** Also available in Ceramic Bearings (-CER).....
or Graphite Bearings (-GR)

***
Also available in Ceramic Bearings (-CER) or Ruby Bearings (-RUB)

Note:
All Nylon Standard Flow Meters,
20 bar/300 PSI
All Stainless Steel Standard Flow Meters,
60 bar/900 PSI
All Nylon High Pressure Flow Meters,
50 bar/750 PSI

MT90-50230		1" 801 Flow Meter with 1" Straight Hose Barbs
MT90-50231		1" 801 Flow Meter with 3/4" Straight Hose Barbs
MT90-50232		1" 801 Flow Meter with 1 1/4" Straight Hose Barbs
MT90-50233		1" 801 Flow Meter with 1 1/4" NPT F
MT57-10080	38410-1/2-BB*	1/2" Nylon Standard Flow Meter, SS Ball Bearings (2S)
MT57-10096	38410-3/4-BB*	3/4" Nylon Standard Flow Meter, SS Ball Bearings (3S)
MT57-10068	38410-1-BB*	1" Nylon Standard Flow Meter, SS Ball Bearings (4S)
MT57-10078	38410-RC-1-BB***	1" Nylon Standard Rpd Chk Flow Meter, SS
MT57-10085	38410-RHP-1-BB***	1" Nylon High Pres Rpd Chk Flow Meter, SS (4RH)
MT57-10081	38410-1 1/2-BB**	1 1/2" Nylon Standard Flow Meter, SS Ball Bearings (6S)
MT57-10079	38410-RC-1 1/2-BB**	1 1/2" Nylon Standard Rpd Chk Flow Meter, SS (6R)
MT57-10097	38410-2-BB**	2" Nylon Standard Flow Meter, SS Ball Bearings (8S)
MT57-10047	38431A-RC-1-RUB	1" RC TeeJet FM Use 121-0104
MT57-10048	38431-RCL-1-BB***	Low Flow Inst for 1" Rpd Chk Flow w/ SS Ball Brng
MT57-10042	38431-RC-1-BB***	Standard Flow Insert, for 1" Rpd Chk Flow Meter with Stainless Steel Ball Bearings
MT57-10045	38431-RCL-1 1/2-BB**	Low Flow Insert, for 1 1/2" Rpd Chk Flow Meter with Stainless Steel Ball Bearings
MT57-10043	38431-RC-1 1/2-BB***	Standard Flow Insert, for 1 1/2" Rpd Chk Flow Meter with Stainless Steel Ball Bearings
MT57-10082	38410SS-1/2-GR	1/2" Stainless Steel Standard Flow Meter, SS (1" NPT)
MT57-10099	38410SS-1-BB**	1" Stainless Steel Standard Flow Meter, SS (1 1/4" NPT)
MT57-10092	38410SS-1 1/2-BB**	1 1/2" Stainless Steel Standard Flow Meter, SS Bearings
MT57-10015	CP38409-1/2-BB*	1/2" Flow Meter Body with Ball Bearings
MT57-10008	CP38409-2-BB**	2" Flow Meter Body with Ball Bearings
MT57-10037	38430-RC-1-BB***	1" Rpd Chk Flow Meter Body with Ball Bearings
MT57-10038	38430-RC-1 1/2-BB**	1 1/2" Rpd Chk Flow Meter Body with Ball Bearings
MT57-10041	38430-RCLF-1-BB**	1" Rpd Chk Flow Meter Body with Ball Bearings and Low Flow Insert
MT57-10055	38411-COMMAT	Pick Up for Standard Flow Meter
MT57-10057	38411-RC-COMMAT	Pick Up for Rpd Chk Flow Meter
MT57-10059	38411-1/2	Pick Up for 1/2" Flow Meter
MT57-10090	CP48213	1" Rpd Chk Body Only Use 121-0100

Optional Flow Meter Fittings

MT90-50006	45916-1000	Hose Barb Kit For 1" Flow Meter; 1" Hose
MT90-50008	45916-1250	Hose Barb Kit For 1" Flow Meter; 1 1/4" Hose
MT90-50007	45916-1	Threaded Connection for 1" Flow Meter; 1" NPT(M)
MT90-50030	38443-750	Hose Barb Kit For 1/2" and 3/4" Flow Meter; 3/4" Hose
MT57-10063	38443-3/4	Threaded Con. for 1/2" and 3/4" Flow Meter; 3/4" NPT (M)
MT90-50024	45977-1250	Hose Barb Kit For 1 1/2" Flow Meter; 1 1/4" Hose
MT90-50026	45977-1500	Hose Barb Kit For 1 1/2" Flow Meter; 1 1/2" Hose
MT90-50028	45977-2000	Hose Barb Kit For 2" Flow Meter; 2" Hose

TEEJET PRESSURE SENSORS

PRESSURE SENSORS



MT16-40001	46104-10	Pressure Sensor, 1/4" NPT, 0-10 BAR/0-145 psi
MT16-40002	46104-25	Pressure Sensor, 1/4" NPT, 0-25 BAR/0-363 psi

TEEJET MANUAL SPRAYER CONTROLS

744A

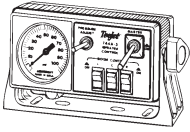

MT90-50149
MT90-50151

744A-100L-3 Sprayer Control Unit (3 Switch with 150 psi/10 bar Liquid-filled Gauge)
744A-300L-3 Sprayer Control Unit (3 Switch with 300 psi/20 bar Liquid Gauge)

TEEJET MANUAL SPRAYER CONTROL KITS



Control Kit No.		Qty Per Kit	Kits Using 144A & 244C Valves
MT90-50161	AAK744A-100L-30S	1	744A-100L-3 Sprayer Control Unit Liquid Gauge
		1	244C-3/4 Pressure Reg. Valve
MT90-50163	AAK744A-100L-33S	1	744A-100L-3 Sprayer Control Unit Liquid Gauge
		1	244C-3/4 Pressure Reg. Valve
		3	144A DirectoValve Boom Section Valves
MT90-50177	AAK744A-100L-33P	1	744A-100D-3 Sprayer Control Unit Liquid Gauge
		1	244C-3/4 Pressure Reg. Valve
		3	144P DirectoValve Boom Section Valves
High Pressure Kits Using 344-2PR Regulating Valves			
Kits below include special wiring harnesses for connecting directly to 3 section TeeJet ball valve manifolds.			
MT90-50238	AAK744A-100L-30B	1	744A-100L-3 Sprayer Control Unit Liquid Gauge
		1	344-2RL Pressure Reg. Valve
MT90-50237	AAK744A-300L-30B	1	744A-300L-3 Sprayer Control Unit Liquid Gauge
		1	344-2RL Pressure Reg. Valve

SPRAYER CONTROL EXTENSION CABLES

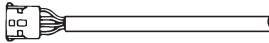

Optional output Extension Cables

MT45-20221	21719-8	8'/2.4m	Extension for 744A-1 (STD)
MT45-20220	21719-15	15'/4.57m	Extension for 744A-1
MT45-20091	21720-8	8'/2.4m	Extension for 744A-3 (STD)
MT45-20079	21720-15	15'/4.57m	Extension for 744A-3
MT45-20104	21721-8	8'/2.4m	Extension for 744A-5 (STD)
MT45-20106	21721-15	15'/4.57m	Extension for 744A-5
MT45-20100	21478-2		Power Cable for 744A
MT45-05385			Ball valve power cable for 744A
MT45-10072			Ball valve harness – console side 12'
MT45-10080			Ball valve harness – valve side

TEXAS INDUSTRIAL MANUAL SPRAYER CONTROLS



TIRC10N Remote Control System with 1-Section Toggle Boom Switch & Pressure Regulator

The RC-10N Remote Control System is the ideal control package for sprayers which require control over only one boom shutoff valve.
Includes 0-100 PSI pressure gauge, mounting bracket, regulator switch, on-off boom switch, 8-ft. power cord with fuse holder and fuse, and a 15-ft. sprayer harness with encased high pressure gauge tubing which acts as both a pressure transmitter and a pulsation dampener.



TIRC1B Remote Control System with 3-Section Toggle Boom Switches & Pressure Regulator

RC-1B Remote Control Systems are designed to give the operator complete and safe control of both spraying pressure and boom shut-down from the tractor seat. The cab harness of the control console attaches to the sprayer harness with molded quick disconnects for quick and easy coupling of the sprayer to the tractor. This exclusive feature also affords the option of cab and sprayer harness lengths most suitable for your tractor and sprayer combination.
Includes 0-100 PSI pressure gauge, adjustable mounting bracket, toggle-type regulator switch, master switch and on-off switches for solenoid shutoff valves, 8 ft. power cord, fuseholder and fuse, and high pressure gauge line encased in a tight-fitting jacket of the wiring harnesses.

Additional configurations of Texas Industrial Sprayer Controls are available. Call Spray Tech for price and availability.

RAVEN Manual Sprayer Controls

RASCS11	Spray Control, 1-way, dry gauge
RASCS203 RASCS20312	Spray Control, 3-way, 3/4" valve, 6' cable, dry gauge Spray Control, 3-way, 3/4" valve, 12' cable, dry gauge
RASCS203L	Spray Control, 3-way, 3/4" valve, 12' cable, liquid gauge

Additional Manual Flow Controls parts are available- Call Spray Tech with any questions.



ACE PUMPS

Features

- The farm industry standard since 1969.

- The 204 motor requires 4 GPM (15.1 LPM) maximum hydraulic fluid input.

Recommended for:

- Pressure Compensating Closed Center Systems
- Open Center Systems up to 13 GPM (49.2 LPM) using internal needle valve bypass.

- The 210 motor requires 10 GPM (37.9 LPM) maximum hydraulic fluid input.

Recommended for:

- Load Sensing Closed Center Systems
- Open Center Systems up to 17 GPM (64.4 LPM) using internal needle valve bypass.

AC204 AC210

$1\frac{1}{2}$ " SUCTION	1" DISCHARGE
-----------------------------	-----------------



Maximum Flow: 92 GPM (350 LPM)
Maximum Pressure: 100 PSI (6.9 BAR)

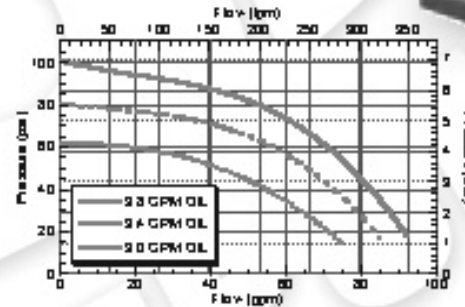

OIL FLOW	
GPM	LPM
3.8	14.4
3.4	12.9
3.0	11.4

Note: Graph for AC210 & AC204 model.

AC206

$1\frac{1}{2}$ " SUCTION	$1\frac{1}{2}$ " DISCHARGE
-----------------------------	-------------------------------



Maximum Flow: 135 GPM (511 LPM)
Maximum Pressure: 120 PSI (8.3 BAR)

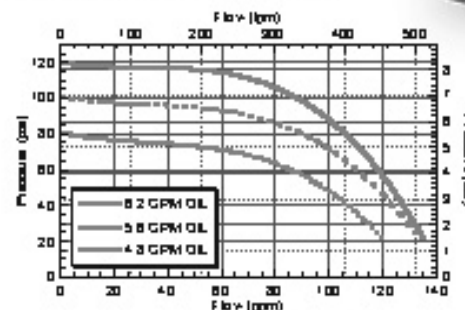

OIL FLOW	
GPM	LPM
6.2	23.5
5.6	21.2
4.8	18.2

150 SERIES HYDRAULIC PUMPS

Features

- Provides higher pressure and greater volume for applications with large tanks and longer spray booms.

- The 206 motor requires 7 GPM (26.5 LPM) maximum hydraulic fluid input and fits virtually all tractor hydraulic systems.

Recommended for:

- Pressure Compensating Closed Center Systems
- Load Sensing Closed Center Systems
- Open Center Systems up to 16 GPM (60.6 LPM) using internal needle valve bypass.

HYDRAULIC DRIVEN CENTRIFUGAL PUMPS

AC206M

1 1/2"
22.0 FLANGE
SUCTION

1 1/4"
20.0 FLANGE
DISCHARGE

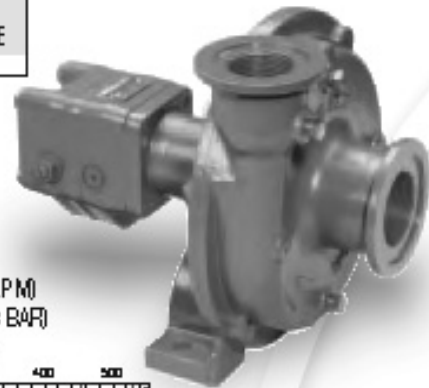

Maximum Flow: 146 GPM (549 LPM)
Maximum Pressure: 120 PSI (8.3 BAR)

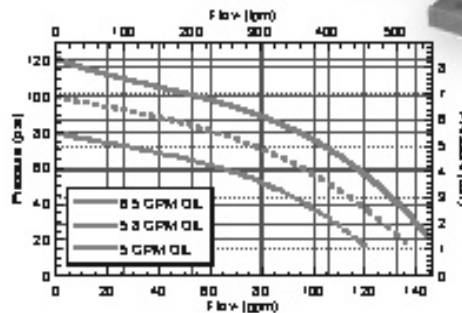

OIL FLOW	
GPM	LPM
6.5	24.6
5.8	21.9
5	18.9

150 SERIES CENTRIFUGAL PUMPS

Features

- F model equipped with NPT ports and industry standard flanged connections.
 - Provides higher pressure and greater volume for applications with large tanks and longer spray booms.
 - The 206 motor requires 7 GPM (26.5 LPM) maximum hydraulic fluid input and fits virtually all tractor hydraulic systems.
- Recommended for:
- Pressure Compensating Closed Center Systems
 - Load Sensing Closed Center Systems
 - Open Center Systems up to 16 GPM (60.6 LPM) using internal needle valve bypass

AC200

2" SUCTION	1½" DISCHARGE
----------------------	-------------------------

200 SERIES HIGH FLOW

Features:

- F model equipped with industry standard flanged connections.
- Ideal for spraying, large tank agitation, liquid transfer, and spray-transfer combinations
- The 210 motor requires 10 GPM (37.9 LPM) maximum hydraulic fluid input.

Recommended for:

- Pressure Compensating Closed Center Systems
- Load Sensing Closed Center Systems
- Open Center Systems up to 17 GPM (64.4 LPM) using internal needle valve bypass



Maximum Flow: 200 GPM (757 LPM)
Maximum Pressure: 120 PSI (8.3 BAR),
80 PSI (5.5 BAR) for 210

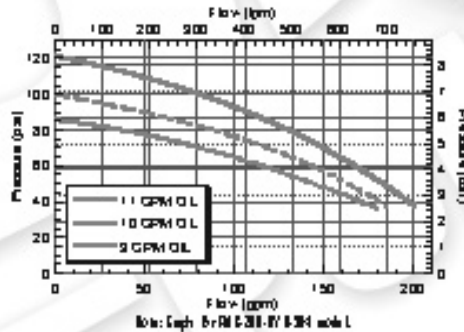

OIL FLOW	
GPM	LPM
11	41.6
10	37.9
9	34.1



Hydraulic Motor Driven Centrifugal Pump

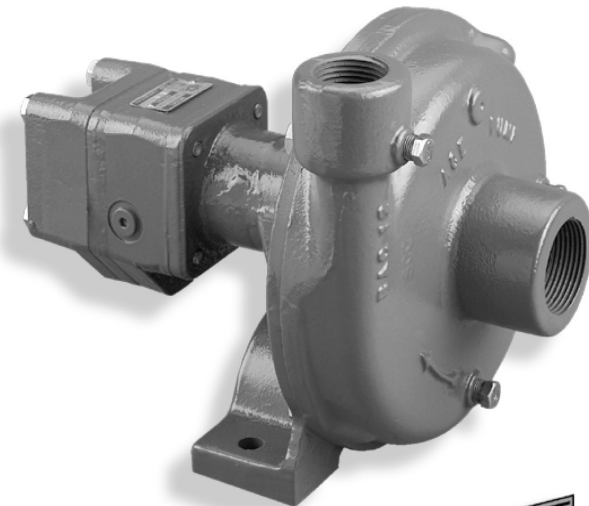

FMC-HYD

- Suction 1-1/4" Discharge 1"
- **-204** motor requires 4 GPM (15.1 LPM) hydraulic flow on PC Closed and Open Center Systems
- **-210** motor requires 10 GPM (37.9 LPM) hydraulic flow on LS Closed and Open Center Systems
- Integral Needle Valve bypasses up to 9 GPM (34 LPM) on Open Center Systems
- Standard Viton® Carbon/Ceramic seal or Optional Severe Duty Silicon Carbide Mechanical Seal
- Chemical Resistant Valox® or Optional Cast Iron Impeller
- Stainless Steel Shaft and Wear Ring

PERFORMANCE CHART

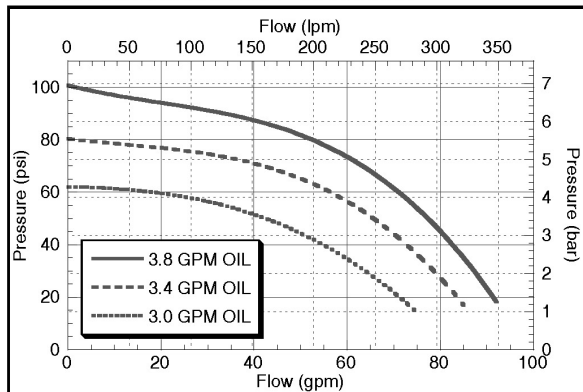

Oil Flow	GPM	3.8	3.4	3.0
Conversion	LPM	14.4	12.9	11.4

Maximum Shutoff Pressure 100 psi

DIMENSIONS

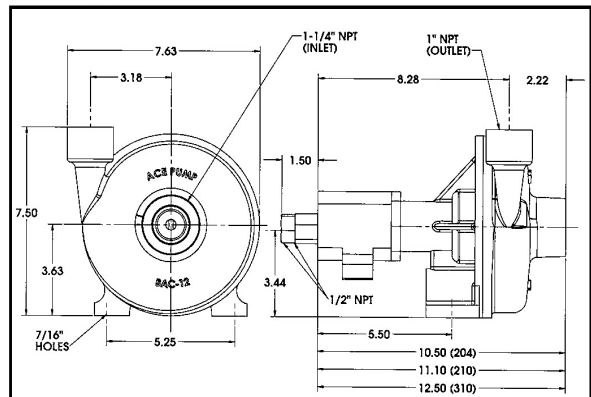

	inches	12.5	11.1	10.5	8.28	7.63	7.5	5.25	3.18	2.22	1.5
	mm	317.5	281.9	266.7	210.3	193.8	190.5	133.4	80.8	56.4	38.1

Valox® is a registered trademark of GE Plastics.
Viton® is a registered trademark of DuPont Dow Elastomers.

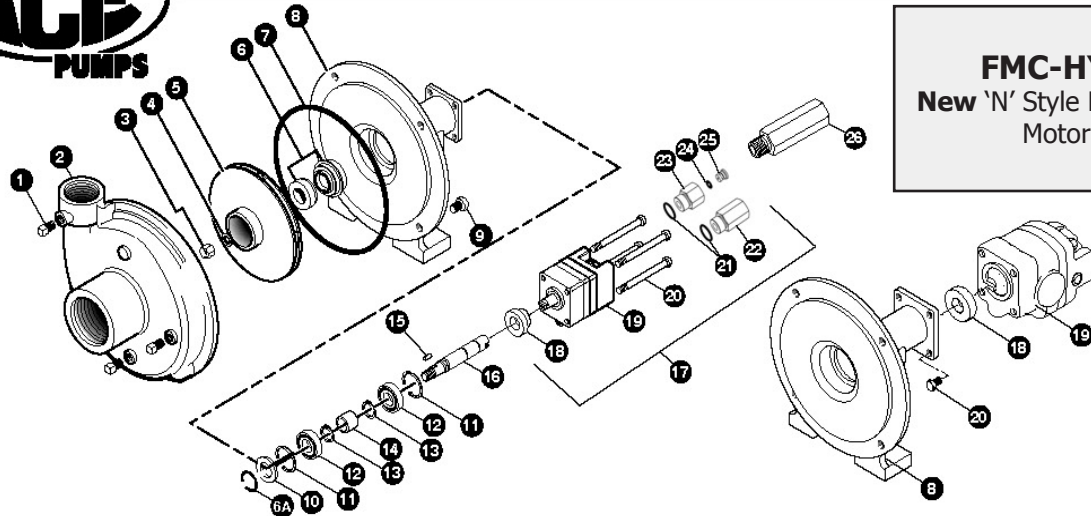

FMC-HYD
New 'N' Style Hydraulic Motor

REF. #	PART NUMBER	EDP #	DESCRIPTION	REQ.
1	BAC-53	41110	Pipe plug	4
1	41120	41120	Pipe plug, stainless steel (optional)	4
2	BAC-12	40250	Volute, 1-1/4" x 1", cast iron	1
3	BAC-23-A	40391	Nut, 3/8" NF, cad plated	1
3	BAC-23-A-SS	40392	Nut, 3/8" NF, stainless steel (optional)	1
4ⓐⓑ	BAC-24-HYD-SS	40400	Washer, 3/8" star, stainless steel	1
5	BAC-26-HYD-VALOX	40440	Impeller, Valox, keyway	1
5	BAC-26-HYD-CI	40442	Impeller, cast iron, keyway (optional)	1
6ⓐ	BAC-7V	40151	Seal, carbon/ceramic/Viton (includes 40160 O-Ring)	1
6ⓑ	BAC-7SC	40152	Seal, silicon carbide/Viton (includes 40160 O-Ring) (optional)	1
6Aⓐⓑ	40160	40160	O-ring, shaft seal	1
7ⓐⓑ	BAC-4A	40005	O-ring, body seal	1
8	BAC-14-HYD	40300	Mounting frame, cast iron (for 200 Series hydraulic motor)	1
8	BAC-14-HYD-300A	40314	Mounting frame, cast iron (for 300A Series hydraulic motor)	1
9	40950	40950	Cap screw, 3/8" NC x 3/4" hex head	4
9	40930	40930	Cap screw, 3/8" NC x 3/8" hex head, stainless steel (optional)	4
10	BAC-54	41130	Slinger	1
11	BAC-33	40810	Snap ring, internal, BAC-14 mounting frame	2
12	BAC-37	40870	Ball Bearing, sealed, BAC-6 shaft	2
13	BAC-32	40790	Snap ring, external, BAC-6 shaft	2
14	BAC-32-S	40795	Spacer for BAC-6 shaft	1
15	BACH-25	40420	Key, 1/8" x 1/8" x 1/2"	1
16	BAC-6-HYD-SS	40061	Shaft, 5/8" diameter, keyway and tang slot, stainless steel	1
17	BAC-75-HYD-204	41370	Hydraulic motor, 4 GPM (includes parts 18 - 25)	1
17	BAC-75-HYD-210	41375	Hydraulic motor, 10 GPM (includes parts 18 - 25)	1
18	S200	40161	Seal support spacer for 200 Series HYD motor	1
18	S300	40162	Seal support spacer for 300 Series HYD motor	1
19	BAC-75-HYD-204N	41433	Hydraulic motor, 4 GPM (motor only - no external fittings)	1
19	BAC-75-HYD-210N	41434	Hydraulic motor, 10GPM (motor only - no external fittings)	1
19	BAC-75-HYD-310	41378	Hydraulic motor, 16 GPM (310A motor effective March 2006)	1
20	41253	41253	Cap screw, 5/16" N. C. x 3-1/2" socket head (for 204N motor)	4
20	41254	41254	Cap screw, 5/16" N. C. x 4" socket head (for 210N motor)	4
20	41330	41330	Cap screw, 5/16" N. C. x 3/4" hex head (for 310 motor)	4
21	41875	41875	O-ring, #8 SAE fitting	2
22	BAC-78-8SAE	41441	Reverse check valve, #8 SAE male x 1/2" NPT female	1
23	BAC-80-8SAE	41455	Adapter, restrictor body, #8 SAE male x 1/2" NPT female	1
24	41448	41448	O-ring, orifice insert	1
25	BAC-79-5	41457	Orifice, restrictor insert, .078 (204N)	1
25	BAC-79-7	41456	Orifice, restrictor insert, .109 (210N)	1
26	LS-204N	41417	Flow limiting valve (204N), #8 SAE male x 1/2" NPT female	1
26	LS-210N	41423	Flow limiting valve (210N), #8 SAE male x 1/2" NPT female	1
ⓐ	RK-FMC	52700	Repair kit for FMC series pump	-
ⓑ	RK-FMCS	52706	Repair kit for FMC series with silicon carbide shaft seal	-
#	RK-BAC-75-HYD-L	41374	Repair kit for 200 series motor with high pressure lip seal	-
#	RK-BAC-75-HYD-300-L	41362	Repair kit for 310 motor with high pressure lip seal	-

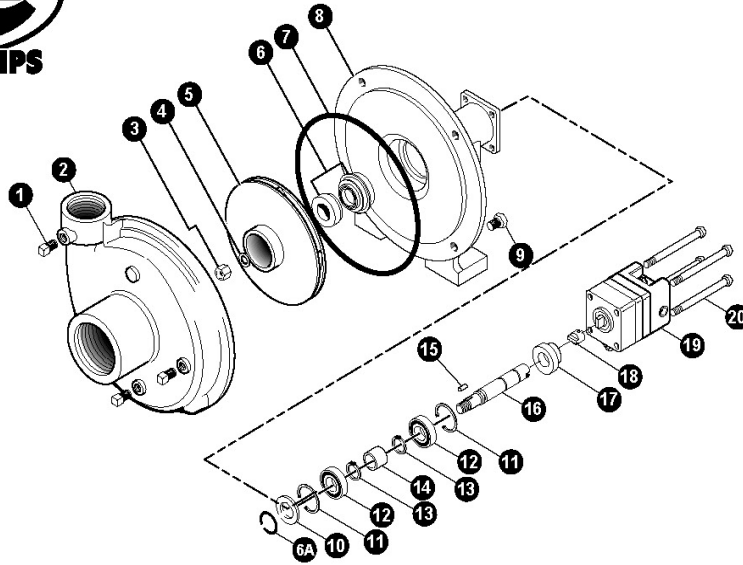

FMC-HYD
Old Style Hydraulic Motor
 Parts still available!

REF. #	PART NUMBER	EDP #	DESCRIPTION	REQ.
1	41110	41110	Pipe plug	3
1	41120	41120	Pipe plug, stainless steel (optional)	3
2	BAC-12	40250	Volute, 1 1/4" x 1"	1
3	BAC-23-A	40391	Nut, 3/8" NF, cad plated	1
4	BAC-24-HYD-SS	40400	Washer, 3/8" star, stainless steel	1
5	BAC-26-HYD-VALOX	40440	Impeller, Valox, keyway	1
5	BAC-26-HYD-CI	40442	Impeller, cast iron, keyway (optional)	1
*6	BAC-7V	40151	Seal, mechanical, Viton (includes 40160)	1
6	BAC-7SC	40152	Seal, mechanical, silicon carbide (includes 40160), (optional)	1
6A	40160	40160	O-ring, shaft seal	1
*7	BAC-4	40010	Gasket, 4 hole, (obsolete 1996)	1
*7	BAC-4A	40005	O-ring, body seal	1
8	BAC-14-HYD	40300	Mounting frame (for -200 Series hydraulic motors)	1
8	BAC-14-HYD-300	40301	Mounting frame (for -310 hydraulic motor)	1
9	40950	40950	Cap screw, 3/8" NC x 3/4" hex head	4
9	40930	40930	Cap screw, 3/8" NC x 3/4" hex head, stainless steel (optional)	4
10	BAC-54	41130	Slinger	1
11	BAC-33	40810	Snap ring, internal, BAC-14 mounting frame	2
12	BAC-37	40870	Ball bearing, sealed, BAC-6 shaft	2
13	BAC-32	40790	Snap ring, external, BAC-6 shaft	2
14	BAC-32-S	40795	Spacer for BAC-6 shaft	1
15	BACH-25	40420	Key, 1/8" x 1/8" x 1/2"	1
16	BAC-6-HYD	40060	Shaft, 5/8" diameter, keyway and tang slot (optional)	1
16	BAC-6-HYD-SS	40061	Shaft, 5/8" diameter, keyway and tang slot, stainless steel	1
17	S200	40161	Seal support spacer for 200 series HYD motor with -L seal	1
18	BAC-76-HYD	41380	Coupling for hydraulic motor	1
19	BAC-75-HYD-204	41370	Hydraulic motor, 4 GPM	1
19	BAC-75-HYD-210	41375	Hydraulic motor, 8 GPM	1
19	BAC-75-HYD-310	41378	Hydraulic motor, 16 GPM	1
20	41256	41256	Cap screw, 5/16" N.C. x 3 1/2" Hex head (for 204 motor)	4
20	41257	41257	Cap screw, 5/16" N.C. x 4" Hex head (for 210 motor)	4
20	41330	41330	Cap screw, 5/16" N.C. x 3/4" Hex head (for 310 motor)	4
#	RK-FMC	52700	Repair kit for FMC series	-
#	RK-BAC-75-HYD	41371	Repair kit for 204 and 210 motor	-
#	RK-BAC-75-HYD-L	41374	Repair kit for 204 and 210 motor with high pressure lip seal	-
#	RK-BAC-75-HYD-310	41379	Repair kit for 310 motor	-
#	RK-BAC-75-HYD-300-L	41362	Repair kit for 310-L motor, effective 04/01	-

* Items included in pump repair kit.



High Performance Hydraulic Motor Driven Centrifugal Pump

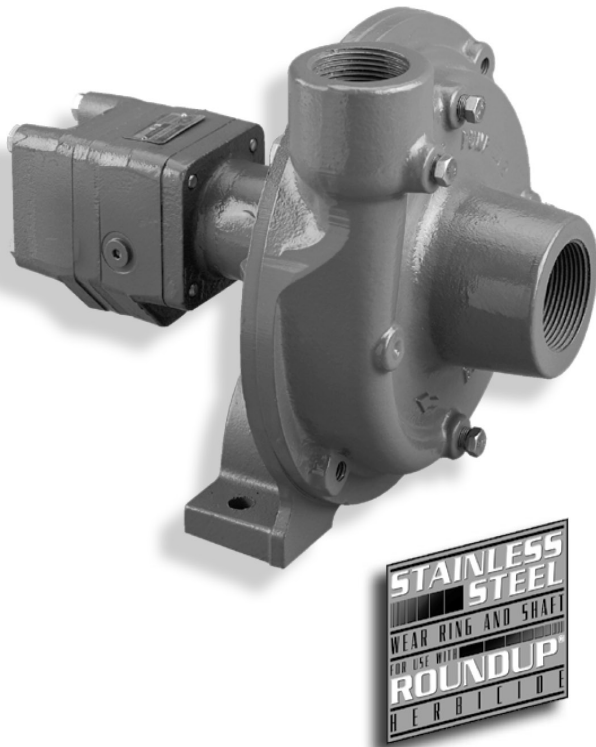

FMC-150-HYD-206

- Suction 1-1/2" Discharge 1-1/4"
- Recommended for use on the following Hydraulic Systems:
 - ✓ Pressure Compensating Closed Center
 - ✓ Load Sensing or Pressure Flow Compensating Closed Center
 - ✓ Open Center up to 16 GPM(60 LPM)
- Integral Needle Valve bypasses up to 9 GPM(34 LPM) on Open Center Systems
- Standard Viton® Carbon/Ceramic seal or Optional Severe Duty Silicon Carbide Mechanical Seal
- Chemical Resistant Valox® or Optional Cast Iron Impeller
- Stainless Steel Shaft and Wear Ring

PERFORMANCE CHART

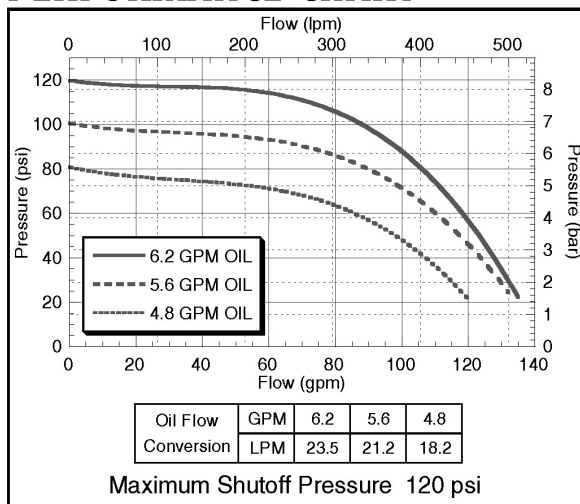

DIMENSIONS

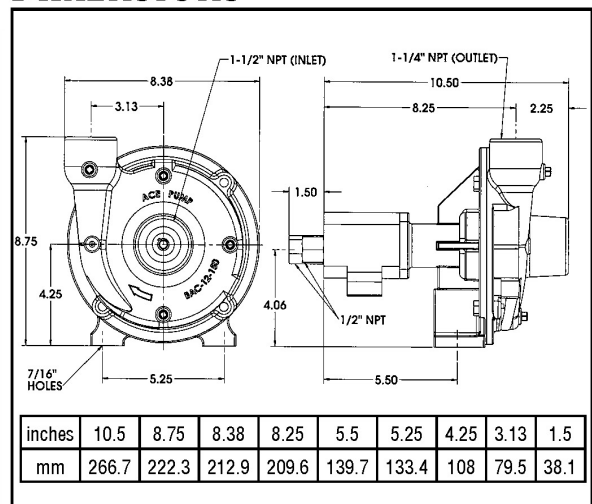

Valox® is a registered trademark of GE Plastics.
 Viton® is a registered trademark of DuPont Dow Elastomers.



FMC-150-HYD-206

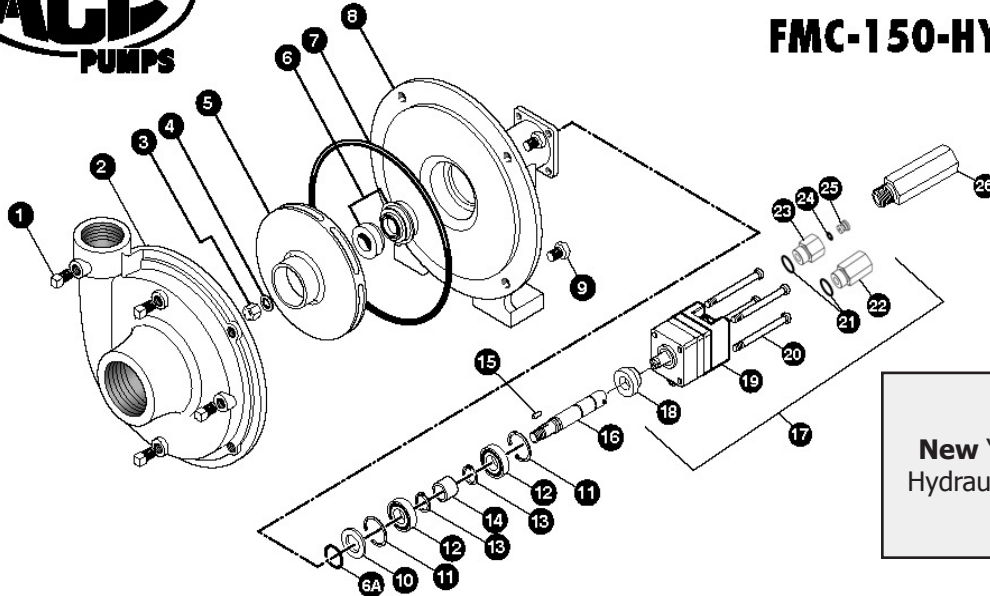

**New 'N' Style
Hydraulic Motor**

REF. #	PART NUMBER	EDP #	DESCRIPTION	REQ.
1	BAC-53	41110	Pipe plug	4
1	41120	41120	Pipe plug, stainless steel (optional)	4
2	BAC-12-150	40255	Volute, 1-1/2" x 1-1/4"	1
3	BAC-23-A	40391	Nut, 3/8" NF, cad plated	1
3	BAC-23-A-SS	40392	Nut, 3/8" NF, stainless steel (optional)	1
4①②	BAC-24-HYD-SS	40400	Washer, 3/8" star, stainless steel	1
5	BAC-26-150-P	40446	Impeller, Valox, keyway	1
5	BAC-26-150-CI	40445	Impeller, cast iron, keyway (optional)	1
6①	BAC-7V	40151	Seal, carbon/ceramic/Viton (includes 40160 O-Ring)	1
6②	BAC-7SC	40152	Seal, silicon carbide/Viton (includes 40160 O-Ring) (optional)	1
6A①②	40160	40160	O-ring, shaft seal	1
7①②	BAC-4-150	40015	O-ring, body seal	1
8	BAC-14-150-HYD	40305	Mounting frame (for 200 Series hydraulic motor)	1
9	40950	40950	Cap screw, 3/8" NC x 3/4" hex head	4
9	40930	40930	Cap screw, 3/8" NC x 3/4" hex head, stainless steel (optional)	4
10	BAC-54	41130	Slinger	1
11	BAC-33	40810	Snap ring, internal, BAC-14 mounting frame	2
12	BAC-37	40870	Ball Bearing, sealed, BAC-6 shaft	2
13	BAC-32	40790	Snap ring, external, BAC-6 shaft	2
14	BAC-32-S	40795	Spacer for BAC-6 shaft	1
15	BACH-25	40420	Key, 1/8" x 1/8" x 1/2"	1
16	BAC-6-HYD-SS	40061	Shaft, 5/8" diameter, keyway and tang slot, stainless steel	1
17	BAC-75-HYD-206	41372	Hydraulic motor, 7 GPM (includes parts 18 - 25)	1
18	S200	40161	Seal support spacer for 200 Series HYD motor	1
19	BAC-75-HYD-206N	41397	Hydraulic motor, 7 GPM (motor only - no external fittings)	1
20	41255	41255	Cap screw, 5/16" N. C. x 3-3/4" socket head (for 206N motor)	4
21	41875	41875	O-ring, #8 SAE fitting	2
22	BAC-78-8SAE	41441	Reverse check valve, #8 SAE male x 1/2" NPT female	1
23	BAC-80-8SAE	41455	Adapter, restrictor body, #8 SAE male x 1/2" NPT female	1
24	41448	41448	O-ring, orifice insert	1
25	BAC-79-7	41456	Orifice, restrictor insert, .109 (206N)	1
26	LS-206N	41418	Flow limiting valve (206N), #8 SAE male x 1/2" NPT female	1
①	RK-FMC-150	52710	Repair kit for FMC-150 series pump	-
②	RK-FMCSC-150	52711	Repair kit for FMC-150 series with silicon carbide shaft seal	-
#	RK-BAC-75-HYD-L	41374	Repair kit for 200 Series motor with high pressure lip seal	-



FMC-150-HYD-206

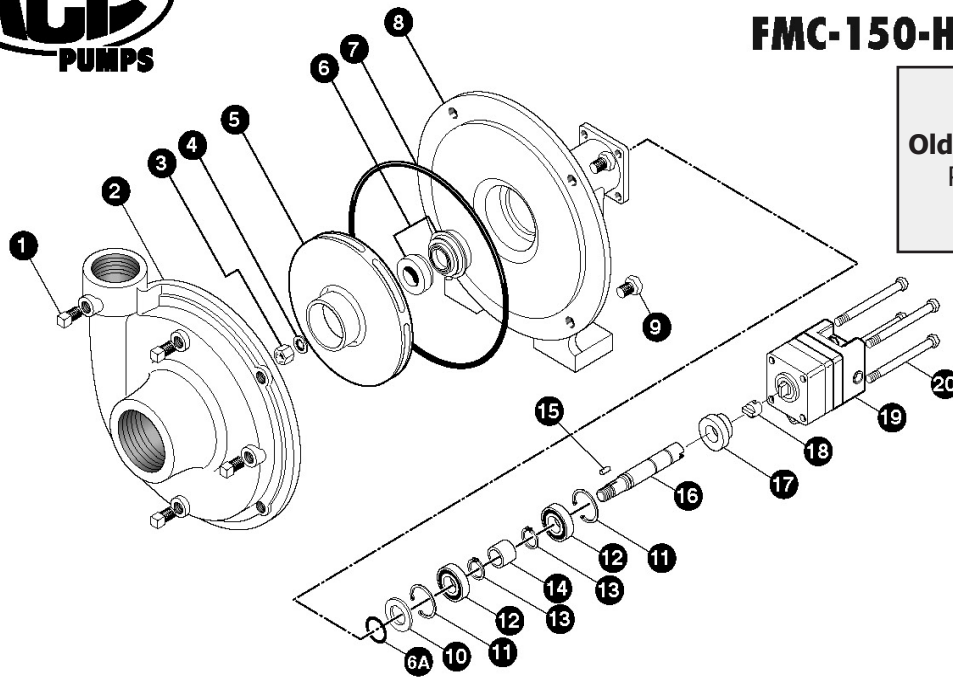

Old Style Hydraulic Motor
Parts still available!

REF. #	PART NUMBER	EDP #	DESCRIPTION	REQ.
1	BAC-53	41110	Pipe plug	4
1	41120	41120	Pipe plug, stainless steel (optional)	4
2	BAC-12-150	40255	Volute, 1-1/2" x 1-1/4"	1
3	BAC-23-A	40391	Nut, 3/8" NF, cad plated	1
4	BAC-24-HYD-SS	40400	Washer, 3/8" star, stainless steel	1
5	BAC-26-150-P	40446	Impeller, Valox, keyway	1
5	BAC-26-150-CI	40445	Impeller, cast iron, keyway (optional)	1
*6	BAC-7V	40151	Seal, mechanical, Viton (includes 40160 O-Ring)	1
6	BAC-7SC	40152	Seal, mechanical, silicon carbide (includes 40160 O-Ring) (optional)	1
6A	40160	40160	O-ring, shaft seal	1
*7	BAC-4-150	40015	O-ring, body seal	1
8	BAC-14-150-HYD	40305	Mounting frame (for 200 Series hydraulic motor)	1
9	40950	40950	Cap screw, 3/8" NC x 3/4" hex head	4
9	40930	40930	Cap screw, 3/8" NC x 3/8" hex head, stainless steel (optional)	4
10	BAC-54	41130	Slinger	1
11	BAC-33	40810	Snap ring, internal, BAC-14 mounting frame	2
12	BAC-37	40870	Ball Bearing, sealed, BAC-6 shaft	2
13	BAC-32	40790	Snap ring, external, BAC-6 shaft	2
14	BAC-32-S	40795	Spacer for BAC-6 shaft	1
15	BACH-25	40420	Key, 1/8" x 1/8" x 1/2"	1
16	BAC-6-HYD-SS	40061	Shaft, 5/8" diameter, keyway and tang slot, stainless steel	1
17	S200	40161	Seal support spacer for 200 Series HYD motor, effective 6/00	1
18	BAC-76-HYD	41380	Coupling for hydraulic motor	1
19	BAC-75-HYD-206	41372	Hydraulic motor, 7 GPM	1
20	41258	41258	Cap screw, 5/16" N. C. x 3-3/4" Hex head (for 206 motor)	4
#	RK-FMC-150	52710	Repair kit for FMC-150 series pump	-
#	RK-BAC-75-HYD	41371	Repair kit for 200 Series motor	-
#	RK-BAC-75-HYD-L	41374	Repair kit for 200-L Series motor	-

* Items included in pump repair kit.

PTO DRIVEN CENTRIFUGAL PUMPS

General Advantages

PTO belt driven centrifugal pumps were first introduced by Ace in 1964 and enabled the applicator to mount centrifugal pumps directly on 540 RPM and 1000 RPM tractor PTO shafts. The simple, yet durable design of the PTOC pump has withstood the test of time while many attempts at imitation have come and gone.

The key to success of the Ace belt driven pump has been the Spring Loaded Idler. The idler maintains proper belt tension which minimizes the load on the pump bearings. More importantly, the idler helps absorb the shock of PTO engagement that can destroy cog belts or gears.

Model PTOC belt driven pumps are easy to operate and maintain. Belts can be replaced in the field with minimum downtime and at little cost. Maintenance features also include sealed ball bearings and a readily replaceable mechanical seal. The belt guard provides complete coverage of the pulleys, shaft and belt. All PTO driven pumps are equipped with a stainless steel shaft and wear ring for excellent corrosion resistance.

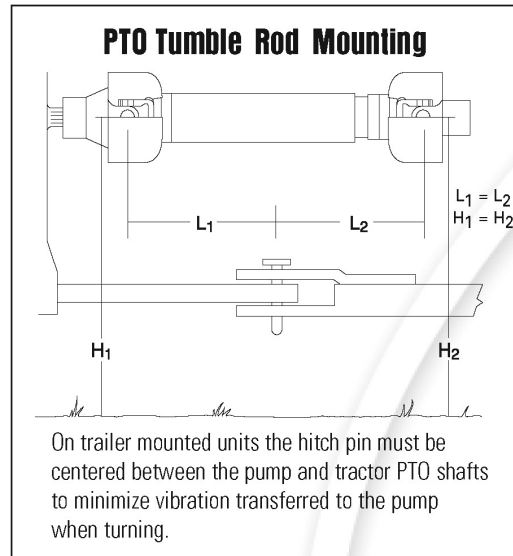
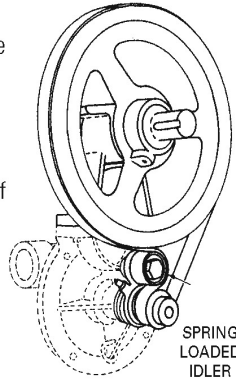

Part Number	Description
AC60010QC AC60010SP	PTOC 600 with quick coupler, 540 rpm PTOC 600 direct mount, 540 rpm
AC100010 AC1000175	PTOC 1000 direct mount, 1 3/8" 21 spline, 1000 rpm PTOC 1000 direct mount, 1 3/4" 20 spline, 1000 rpm

1 1/4" SUCTION	1" DISCHARGE
--------------------------	------------------------

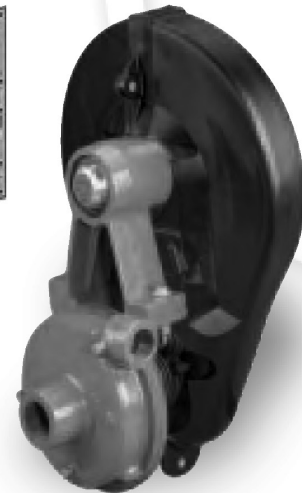

Features

- Maximum Flow: 65 GPM (246 LPM)
- Maximum Pressure: 80 PSI (5.5 BAR)
- The original belt drive standard since 1964
- Time tested and field proven design
- Widespread parts and service availability
- Most Economical belt drive

©Roundup is a registered trademark of Monsanto Company.

PTOC-600

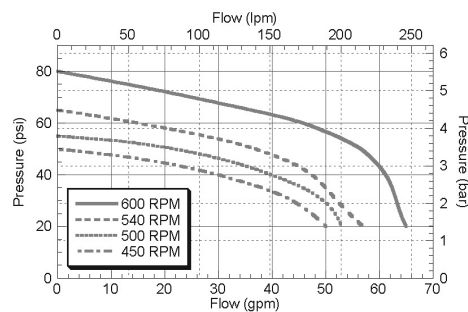

PTOC-1000

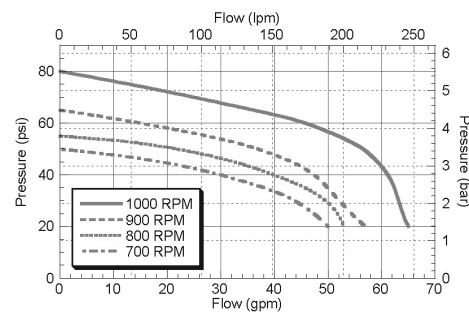

PTO Shaft Options

-6SP



1 3/4" (34.9 MM)
6 spline shaft for
540 FPM models

-6SPQC



Instant-attach
quick coupler for
540 FPM models

-21SP



21 spline 1 3/4" (34.9 MM)
split bore shaft with
locking collar for
1000 FPM models

-20SP



20 spline 1 3/4" (44.5 MM)
split bore shaft with
locking collar for
1000 FPM models

-B



1" (25.4 MM) stub shaft
for installation on trailer
sprayers driven by
PTO tumblerod

PTOC High-Performance

Part Number	Description
AC150600Q AC150600B	PTOC 150-600 with quick coupler, 540 rpm PTOC 150-600 direct mount, 1" shaft, 540 rpm
AC150M20SP AC150M21SP	PTOC 150-1000 direct mount, 1 3/4" 20 spline, 1000 rpm PTOC 150-1000 direct mount, 1 3/4" 21 spline, 1000 rpm

1 1/2"

SUCTION

1 1/4"

DISCHARGE

Features

- Maximum Flow: 100 GPM (378 LPM)
- Maximum Pressure: 110 PSI (7.6 BAR)
- The High Performance Pump: 100 PSI (6.9 BAR) at 40 GPM (151 LPM) due to increased pulley ratio and larger 1 1/2" x 1 1/4" construction
- Provides higher pressure and greater volume for applications with large tanks and long spray booms
- Allows fuel savings by operating at lower engine speeds while maintaining adequate spraying pressures



PTOC-150-600

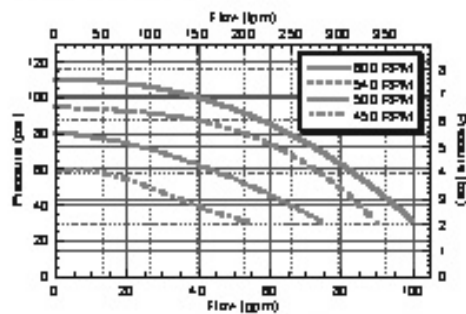

PTOC-150-1000

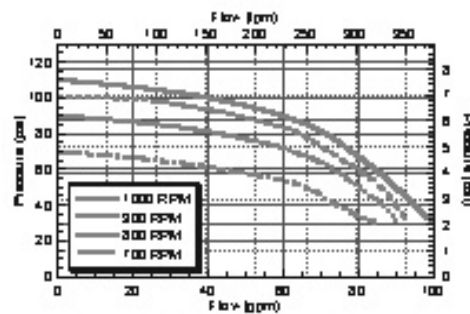

BELT DRIVEN CENTRIFUGAL PUMPS

General Advantages

Frame Mount Advantages

Ace belt driven pumps are available in a variety of models which can be belt driven or direct coupled to a power source. The pumps are available in either clockwise or counterclockwise rotation. The standard bare shaft pumps are designed with a keyway for mounting a drive pulley or coupling.

Magnetic Clutch Driven Advantages

The integral magnetic clutch driven centrifugal pump design was first offered by Ace in 1982. These models enabled the operator to free the PTO shaft and hydraulic system for other uses. The 12 volt DC magnetic clutch is driven by a v-belt from the engine drive shaft. The clutch is idle until engaged by an on-off toggle switch located at the driver's seat.

Typical Clutch Installation

Ace magnetic clutch driven frame mounted centrifugal pump models are available with counterclockwise (ccw) rotation and clockwise (cw) rotation. The direction of rotation is determined when facing the shaft. Sizes available are 1 1/4" x 1", 1 1/2" x 1 1/4", and 2" x 1 1/2".

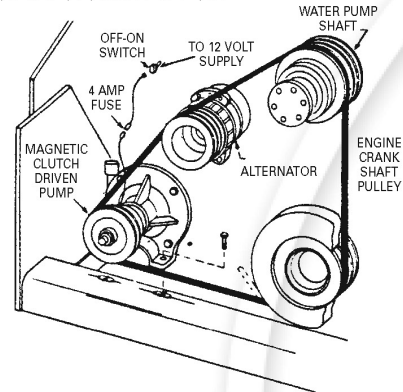

-MAG-D CLUTCH

- 58 ft. lb. (78.6 NM) torque capacity
- Forged machined pulley for maximum strength
- Solid forged rotor to maximize torque
- E-coated for maximum corrosion protection
- High temperature epoxy coil
- Two bearings with high temperature, long life grease
- Single or double belt drive
- 4 3/4" (12.1 CM) pitch diameter

MAGNETIC CLUTCH CENTRIFUGAL PUMPS

Part Number	Description
FMCMAG	1 1/4" x 1" CCW
AC47030	1 1/2" x 1 1/4" CCW
ACSCPUMP	Spra-Coupe replacement pump CW

FMC FMC-MAG-D

1 1/4" SUCTION	1" DISCHARGE
--------------------------	------------------------

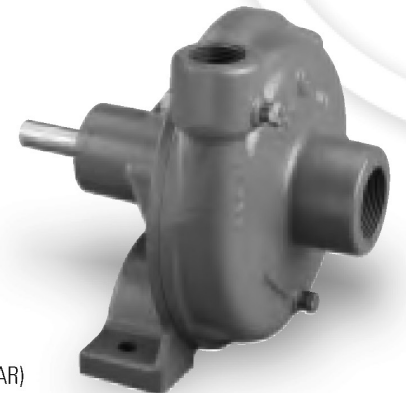

Maximum Flow: 70 GPM (265 LPM)
Maximum Pressure: 170 PSI (11.7 BAR)
Maximum Power: 4.2 HP (3.1 KW)

FRAME-MOUNTED CENTRIFUGAL PUMPS	
Part Number	Description
FMC	1 1/4" x 1" CCW
FMC150MIA	1 1/2" x 1 1/4" CCW w/ idler arm mount
FMC200	2" x 1 1/2" CCW
FMCCW150	1 1/2" x 1 1/4" CW
FMCCW200	2" x 1 1/2" CW
FMCMIA	1 1/4" x 1" CCW w/ idler arm mount

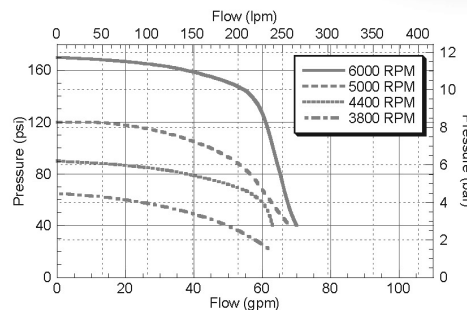

Centrifugal/Turbine Pumps and Accessories

**Ready for use
with Roundup®!**

Individually Tested

Additional features:

- Life Guard® silicon carbide seals standard in all stainless steel models
- Viton® mechanical seals standard in all cast iron and polypropylene models
- Stainless steel wear rings standard in all cast iron models
- Corrosion-resistant impellers standard in all models

Rotation, clockwise or counterclockwise, is determined when looking at the shaft end of the pump.

Roundup is a registered trademark of Monsanto Company.

9000 Series Cast Iron, Gear-Driven Models



Model Number	Max. GPM	Max. PSI	Max. RPM	Description	Estimated Weight Ea.
9006C-O	117	78	600	Cast iron pump with oil-lubricated gear drive and 1½" 540 rpm female PTO hub with locking collar and mounting clip. Clips pump to PTO shield of most tractors. 1½" Inlet, 1¼" outlet.	45 lbs.
9008C-O	115	76	1000	Cast iron pump with oil-lubricated gear drive and 1½" 1000 rpm female PTO hub with locking collar and mounting clip. Clips pump to PTO shield of most tractors. 1½" Inlet, 1¼" outlet.	46 lbs.
9016C-O	117	78	600	Cast iron pump with oil-lubricated gear drive and 1" solid shaft, ports (NPT): 1½" Inlet, 1¼" outlet.	43 lbs.
9018C-O	115	76	1000	Cast iron pump with oil-lubricated gear drive and 1" solid shaft, ports (NPT): 1½" Inlet, 1¼" outlet.	43 lbs.
9028C-O	115	76	1000	Cast iron pump with oil-lubricated gear drive and 1½" 1000 rpm female PTO hub with locking collar and mounting clip. Clips pump to PTO shield of most tractors. 1½" Inlet, 1¼" outlet.	49 lbs.
3430-0334	Seal and o-ring repair kit				4 oz.
3430-0591	Life Guard® silicon carbide seal kit				4 oz.

Available by special order: **Life Guard® silicon carbide seal** - Add Suffix "B" - (i.e.: 9006C-O-B) -

The Spray Tech part number can be derived by adding the prefix 'HY' to the listed Hypro numbers.

9000 Series Polypropylene, Gear-Driven Models

Model Number	Max. GPM	Max. PSI	Max. RPM	Description	Estimated Weight Ea.
9006P-O	97	83	600	Corrosion-resistant and durable polypropylene pump with oil-bath lubricated gear drive for PTO mounting. Viton® seals and 1½" 540 rpm female PTO hub w/locking collar kit.	37 lbs.
9008P-O	86	67	1000	Corrosion-resistant and durable polypropylene pump with oil-bath lubricated gear drive for PTO mounting. Viton® seals and 1½" 1000 rpm female PTO hub with locking collar kit.	37 lbs.
9016P-O	97	83	600	Corrosion-resistant and durable polypropylene pump with oil-bath lubricated gear drive and 1" solid shaft. Viton® seals.	37 lbs.
9018P-O	86	67	1000	Corrosion-resistant and durable polypropylene pump with oil-bath lubricated gear drive and 1" solid shaft. Viton® seals.	37 lbs.
3430-0333	Seal and o-ring repair kit				4 oz.
3430-0590	Life Guard® silicon carbide seal kit				4 oz.

Available by special order: **Life Guard® silicon carbide seal** - Add Suffix "B" - (i.e.: 9006P-O-B) -

9200 Series Cast Iron, Pedestal-Mount Models

Model Number	Max. GPM	Max. PSI	Max. RPM	Description	Estimated Weight Ea.
9202C	105	170	6000	Pedestal mount, cast iron pump with ¾" solid shaft and Viton® shaft seal. 1¼" Inlet, 1" outlet NPT ports.	17 lbs.
9203C [†]	140	170	6000	Pedestal mount, cast iron pump with ¾" solid shaft and Viton® shaft seal. 1½" Inlet, 1¼" outlet NPT ports.	17 lbs.
9203C-R	140	170	6000	Pedestal mount, clockwise rotation cast iron pump, with ¾" solid shaft, Viton® seal and 1½" x 1¼" NPT ports.	17 lbs.
9205C	180	190	4200	Pedestal mount, cast iron pump with ¾" solid keyed shaft, Viton® seal, and 2" inlet x 1½" outlet NPT ports.	38 lbs.
9206C ^{††}	225	80	4200	Pedestal mount, cast iron pump with ¾" solid shaft and Viton® shaft seal. 2" Inlet, 1½" outlet NPT ports.	23 lbs.
3430-0332	Seal and o-ring repair				3 oz.
430-0537	Seal and o-ring repair kit (9205 models)				4 oz.
3430-0589	Life Guard® silicon carbide seal kit				3 oz.
3430-0646	Life Guard® silicon carbide seal kit (9205 models)				4 oz.

Life Guard® silicon carbide seal - Add Suffix "B" - (i.e.: 9203C-B)

[†] Universal flange (220 x 200) - Add Suffix "U" - (i.e.: 9203C-U)

^{††} Universal flange (220 x 220) - Add Suffix "U" - (i.e.: 9206C-U)

The Spray Tech part number can be derived by adding the prefix 'HY' to the listed Hypro numbers.

9200 and 9500 Series Polypropylene Pedestal-Mount Models



Model Number	Max. GPM	Max. PSI	Max. RPM	Description	Estimated Weight Ea.
9203P-S	100	80	4200	Pedestal mount pump designed for direct drive with an electric motor or belt and pulley drive with an electric motor or gas engine, 7/8" solid keyed 316 stainless steel shaft, 1 1/2" inlet 1 1/4" outlet.	14 lbs.
9500P-S	100	80	4200	Clockwise rotation pedestal mounted pump designed for direct drive with a gas engine or electric motor, 7/8" solid keyed 316 stainless steel shaft, 1 1/2" inlet 1 1/4" outlet.	13 lbs.
3430-0333	Seal and o-ring repair kit				4 oz.
3430-0590	Life Guard® silicon carbide seal kit				4 oz.

9200 Series Stainless Steel, Pedestal-Mount Models



Model Number	Max. GPM	Max. PSI	Max. RPM	Description	Estimated Weight Ea.
9202S	105	170	6000	Pedestal mount, 316 stainless steel pump with 5/8" solid 416 stainless steel shaft and Life Guard® silicon carbide shaft seal. Ports (NPT): 1 1/4" inlet; 1" outlet.	18 lbs.
9203S	140	170	6000	Pedestal mount, 316 stainless steel pump with 5/8" solid 416 stainless steel shaft and Life Guard® silicon carbide shaft seal. Ports (NPT): 1 1/2" inlet, 1 1/4" outlet.	19 lbs.
9203S-R	140	170	6000	Pedestal mount, clockwise rotation, 316 stainless steel pump with 5/8" solid 416 stainless steel shaft and Life Guard® silicon carbide shaft seal. Ports (NPT): 1 1/2" inlet, 1 1/4" outlet.	37 lbs.
9206S	225	80	4200	Pedestal mount, 316 stainless steel pump with 5/8" solid 416 stainless steel shaft and Life Guard® silicon carbide shaft seal. Ports (NPT): 2" inlet, 1 1/2" outlet.	23 lbs.

The Spray Tech part number can be derived by adding the prefix 'HY' to the listed Hypro numbers.

9200 Series Cast Iron, Pedestal-Mount Models with 12-Volt Clutch



Model Number	Max. GPM	Max. PSI	Max. RPM	Description	Estimated Weight Ea.
9262C-C	88	124	5000	Pedestal mount, cast iron pump with 12-volt heavy duty clutch with 5" diameter A-section pulley, 1½" NPT inlet, 1" NPT outlet, counterclockwise rotation.	22 lbs.
9263C-C†	140	124	5000	Pedestal mount, cast iron pump with 12-volt heavy duty clutch with 5" diameter A-section pulley, 1½" NPT inlet, 1¼" NPT outlet, counterclockwise rotation.	23 lbs.
9263C-CR	140	124	5000	Pedestal mount, cast iron pump with 12-volt heavy duty clutch with 5" diameter A-section pulley, (3430-0592) 1½" NPT inlet, 1¼" NPT outlet, clockwise rotation.	21 lbs.
3430-0332	Seal and o-ring repair kit				3 oz.
3430-0589	Life Guard® silicon carbide seal kit				3 oz.

Life Guard® silicon carbide seal - Add Suffix "B" - (i.e.: 9262C-C-B)

† Universal flange (220 x 200) - Add Suffix "U" - (i.e.: 9262C-C-U)

9200 Series Polypropylene, Pedestal-Mount Models with 12-Volt Clutch



Model Number	Max. GPM	Max. PSI	Max. RPM	Description	Estimated Weight Ea.
9253P-C	100	80	4200	Pedestal mount, polypropylene pump with 12-volt heavy duty clutch with 5¼" diameter A-section pulley, 1½" NPT inlet, 1¼" NPT outlet, counterclockwise rotation.	20 lbs.
9553P-C	100	80	4200	Pedestal mount, polypropylene pump with 12-volt heavy duty clutch with 5¼" diameter A-section pulley, 1½" NPT inlet 1¼" NPT outlet, clockwise rotation.	19 lbs.
3430-0333	Seal and o-ring repair kit				4 oz.
3430-0590	Life Guard® silicon carbide seal kit				3 oz.

Life Guard® silicon carbide seal - Add Suffix "B" - (i.e.: 9553P-C)

9200 Series Stainless Steel, Pedestal-Mount Models with 12-Volt Clutch



Model Number	Max. GPM	Max. PSI	Max. RPM	Description	Estimated Weight Ea.
9262S-C	88	124	5000	Pedestal mount, stainless steel pump with 12-volt heavy duty clutch with 5" diameter A-section pulley, 416 stainless steel shaft and Life Guard® silicon carbide shaft seal, 1½" NPT inlet, 1" NPT outlet, counterclockwise rotation.	27 lbs.
9263S-C	140	124	5000	Pedestal mount, stainless steel pump with 12-volt heavy duty clutch with 5" diameter A-section pulley, (3430-0592), 416 stainless steel shaft and Life Guard® silicon carbide shaft seal, 1½" NPT inlet, 1¼" NPT outlet, counterclockwise rotation.	26 lbs.
9263S-CR	140	124	5000	Pedestal mount, stainless steel pump with 12-volt heavy duty clutch with 5" diameter A-section pulley, (3430-0592), 416 stainless steel shaft and Life Guard® silicon carbide shaft seal, 1½" NPT inlet, 1¼" NPT outlet, clockwise rotation.	26 lbs.

The Spray Tech part number can be derived by adding the prefix 'HY' to the listed Hypro numbers.

9300 Series Cast Iron, Hydraulic Motor-Driven Models

The hydraulic motor features a fixed displacement internal gear design for smooth operation. A double lip Teflon shaft seal provides excellent reliability even with high hydraulic oil back pressure. The hardened stainless steel motor/pump shaft is supported by two needle bearings and a ball bearing for dependable operation through years of use.

Model Number	Max. GPM	Max. PSI	Description	Estimated Weight Ea.
9302CT-GM1	63	105	2-3 gpm hydraulic gear motor/cast iron pump for open/closed center systems, ports (NPT): 1/4" inlet, 1" outlet.	26 lbs.
9302C-HM1C	72	150	13 gpm hydraulic motor/cast iron pump for open/closed center systems, ports (NPT): 1/4" inlet, 1" outlet.	26 lbs.
9302C-HM2C	65	96	6 gpm hydraulic motor/cast iron pump for closed center systems, ports (NPT): 1/4" inlet, 1" outlet.	26 lbs.
9302C-HM4C	72	120	7 gpm hydraulic motor/cast iron pump, open/closed center systems, ports (NPT): 1/4" inlet, 1" outlet.	26 lbs.
9303C-HM1C*	114	130	13 gpm hydraulic motor/cast iron pump for open/closed center systems, ports (NPT): 1/2" inlet, 1/4" outlet.	26 lbs.
9303C-HM2C	97	95	6 gpm hydraulic motor/cast iron pump for closed center systems, ports (NPT): 1/2" inlet, 1/4" outlet.	26 lbs.
9303C-HM3C*	125	98	24 gpm hydraulic motor/cast iron pump, large open center systems, ports (NPT): 1/2" inlet, 1/4" outlet.	26 lbs.
9303C-HM4C	115	93	7 gpm hydraulic motor/cast iron pump, open/closed center systems, ports (NPT): 1/2" inlet, 1/4" outlet.	26 lbs.
9303C-HM5C*	147	145	16 gpm hydraulic motor/cast iron pump, open/closed center systems, ports (NPT): 1/2" inlet, 1/4" outlet.	26 lbs.
9305C-HM3C	182	160	19 gpm hydraulic motor/cast iron pump, large open center systems, ports (NPT): 2" inlet, 1 1/2" outlet.	33 lbs.
9306C-HM1C**	207	130	13 gpm hydraulic motor/cast iron pump, open/closed center systems, ports (NPT): 2" inlet, 1 1/2" outlet.	33 lbs.
9306C-HM3C**	214	135	24 gpm hydraulic motor/cast iron pump, open/closed center systems, ports (NPT): 2" inlet, 1 1/2" outlet.	33 lbs.
9306C-HM5C**	212	140	17 gpm hydraulic motor/cast iron pump, open/closed center systems, ports (NPT): 2" inlet, 1 1/2" outlet.	33 lbs.
9307C-GM10†	358	135	20 gpm hydraulic gear motor/cast iron pump for open/closed center systems with Life Guard® silicon carbide seal, ports (NPT): 3" inlet, 2" outlet.	86 lbs.
9307C-GM12†	358	135	22 gpm hydraulic gear motor/cast iron pump for open/closed center systems with Life Guard® silicon carbide seal, ports (NPT): 3" inlet, 2" outlet.	86 lbs.
3430-0332	Seal and o-ring repair kit			3 oz.
3430-0500	Seal and o-ring repair kit (9305 models)			3 oz.
3430-0589	Life Guard® silicon carbide seal kit (9302 and 9303 models)			3 oz.
3430-0601	Life Guard® silicon carbide seal kit (9305 models)			3 oz.
3430-0604	Life Guard® silicon carbide seal kit (9307 models)			3 oz.

Life Guard® silicon carbide seal - Add Suffix "B" - (i.e.: 9303C-HM4C-B)

* Universal flange (220 x 200) - Add Suffix "U" - (i.e.: 9303C-HM3C-U)

** Universal flange (220 x 220) - Add Suffix "U" - (i.e.: 9306C-HM3C-U) -

† Due to size and weight of pump, only truck routing is recommended. Hypro will not be responsible for damage in shipment for other transit requests.

The Spray Tech part number can be derived by adding the prefix 'HY' to the listed Hypro numbers.

9300 Series Stainless Steel, Hydraulic Motor-Driven Models

Model Number	Max. GPM	Max. PSI	Description	Estimated Weight Ea.
9302ST-GM1	63	105	2-3 gpm hydraulic gear motor/316 stainless steel pump with 416 stainless steel shaft and Life Guard® silicon carbide seals. 1½" NPT inlet, 1" NPT outlet.	26 lbs.
9302S-HM1C	72	150	13 gpm hydraulic motor/316 stainless steel pump for open/closed center systems with 416 stainless steel shaft and Life Guard® silicon carbide seals. 1½" NPT inlet, 1" NPT outlet.	26 lbs.
9302S-HM2C	65	96	6 gpm hydraulic motor/316 stainless steel pump for open/closed center systems with 416 stainless steel shaft and Life Guard® silicon carbide seals. 1½" NPT inlet, 1" NPT outlet.	26 lbs.
9302S-HM4C	72	120	7 gpm hydraulic motor/316 stainless steel pump for open/closed center systems with 416 stainless steel shaft and Life Guard® silicon carbide seals. 1½" NPT inlet, 1" NPT outlet.	26 lbs.
9303S-HM1C	114	130	13 gpm hydraulic motor/316 stainless steel pump for open/closed center systems with 416 stainless steel shaft and Life Guard® silicon carbide seals. 1½" NPT inlet, 1½" NPT outlet.	26 lbs.
9303S-HM2C	97	95	6 gpm hydraulic motor/316 stainless steel pump for open/closed center systems with 416 stainless steel shaft and Life Guard® silicon carbide seals. 1½" NPT inlet, 1½" NPT outlet.	26 lbs.
9303S-HM3C	125	98	24 gpm hydraulic motor/316 stainless steel pump for open/closed center systems with 416 stainless steel shaft and Life Guard® silicon carbide seals. 1½" NPT inlet, 1½" NPT outlet.	26 lbs.
9303S-HM4C	115	93	7 gpm hydraulic motor/316 stainless steel pump for open/closed center systems with 416 stainless steel shaft and Life Guard® silicon carbide seals. 1½" NPT inlet, 1½" NPT outlet.	26 lbs.
9303S-HM5C	147	145	16 gpm hydraulic motor/316 stainless steel pump for open/closed center systems with 416 stainless steel shaft and Life Guard® silicon carbide seals. 1½" NPT inlet, 1½" NPT outlet.	26 lbs.
9306S-HM1C	207	130	13 gpm hydraulic motor/316 stainless steel pump for open/closed center systems with 416 stainless steel shaft and Life Guard® silicon carbide seals. 2" NPT inlet, 1½" NPT outlet.	33 lbs.
9306S-HM3C	214	135	24 gpm hydraulic motor/316 stainless steel pump for open/closed center systems with 416 stainless steel shaft and Life Guard® silicon carbide seals. 2" NPT inlet, 1½" NPT outlet.	33 lbs.
9306S-HM5C	212	140	17 gpm hydraulic motor/316 stainless steel pump for open/closed center systems with 416 stainless steel shaft and Life Guard® silicon carbide seals. 2" NPT inlet, 1½" NPT outlet.	33 lbs.



9300 Series Polypropylene, Hydraulic Motor-Driven Models

Model Number	Max. GPM	Max. PSI	Description	Estimated Weight Ea.
9303P-HM1C	110	130	13 gpm hydraulic motor/polypropylene pump for open/closed center systems, ports (NPT): 1½" inlet, 1¼" outlet.	20 lbs.
9303P-HM2C	82	95	6 gpm hydraulic motor/polypropylene pump for closed center systems, ports (NPT): 1½" inlet, 1¼" outlet.	19 lbs.
9303P-HM3C	110	93	24 gpm hydraulic motor/polypropylene pump, large open center systems, ports (NPT): 1½" inlet, 1¼" outlet.	21 lbs.
9303P-HM4C	82	85	7 gpm hydraulic motor/polypropylene pump, open/closed center systems, ports (NPT): 1½" inlet, 1¼" outlet.	19 lbs.
9303P-HM5C	116	120	16 gpm hydraulic motor/polypropylene pump, open/closed center systems, ports (NPT): 1½" inlet, 1¼" outlet.	20 lbs.
3430-0445	Seal and o-ring repair kit			3 oz.
3430-0593	Life Guard® silicon carbide seal kit			3 oz.



Life Guard® silicon carbide seal - Add Suffix "B" - (i.e.: 9303P-HM4C-B)

The Spray Tech part number can be derived by adding the prefix 'HY' to the listed Hypro numbers.

9400 Series Cast Iron, Belt-Driven Models with 12-Groove Belt and Idler Pulley



Model Number	Max. GPM	Max. PSI	Max. RPM	Description	Estimated Weight Ea.
9402C-540	76	95	600	Belt-driven, cast iron pump with 1½" hollow, 6-spline shaft, 1¼" inlet, 1" outlet.	45 lbs.
9402C-540Q	76	95	600	Belt-driven, cast iron pump with 1½" 6-spline quick coupler shaft, 1¼" inlet, 1" outlet.	45 lbs.
9402C-540S	76	95	600	Belt-driven, cast iron pump with 1" solid shaft, 1½" inlet, 1" outlet.	45 lbs.
9402C-1000	76	95	1000	Belt-driven, cast iron pump with 1½" hollow, 21-spline shaft, 1¼" inlet, 1" outlet.	42 lbs.
9402C-1000L	76	95	1000	Belt-driven, cast iron pump with 1½" hollow, 20-spline shaft, 1¼" inlet, 1" outlet.	42 lbs.
9402C-1000S	76	95	1000	Belt-driven, cast iron pump with 1" solid shaft, 1½" inlet, 1" outlet.	42 lbs.
9403C-540†	140	104	600	Belt-driven, cast iron pump with 1½" hollow, 6-spline shaft, 1½" inlet, 1¼" outlet.	45 lbs.
9403C-540Q†	140	104	600	Belt-driven, cast iron pump with 1½" 6-spline quick coupler shaft, 1½" inlet, 1¼" outlet.	45 lbs.
9403C-540S†	140	104	600	Belt-driven, cast iron pump with 1" solid shaft, 1½" inlet, 1¼" outlet.	45 lbs.
9403C-1000†	140	104	1000	Belt-driven, cast iron pump with 1½" hollow, 21-spline shaft, 1½" inlet, 1¼" outlet.	42 lbs.
9403C-1000L†	140	104	1000	Belt-driven, cast iron pump with 1½" hollow, 20-spline shaft, 1½" inlet, 1¼" outlet.	42 lbs.
9403C-1000S†	140	104	1000	Belt-driven, cast iron pump with 1" solid shaft, 1½" inlet, 1¼" outlet.	42 lbs.
3430-0332	Seal and o-ring repair kit				3 oz.
3430-0476	Seal, o-ring, belt and gasket repair kit for 540 rpm drives				1 lb.
3430-0477	Seal, o-ring, belt and gasket repair kit for 1000 rpm drives				1 lb.
3430-0589	Life Guard® silicon carbide seal and o-ring kit				3 oz.

Life Guard® Silicon Carbide Seal - Add Suffix "B" - (i.e.: 9403C-540Q-B)

†Universal flange (220 x 200) - Add Suffix "U" - (i.e.: 9403C-540Q-U)

The Spray Tech part number can be derived by adding the prefix 'HY' to the listed Hypro numbers.



9400 Series Polypropylene, Belt-Driven Models with 12-Groove Belt and Idler Pulley



Model Number	Max. GPM	Max. PSI	Max. RPM	Description	Estimated Weight Ea.
9403P-540	86	82	600	Belt-driven, polypropylene pump with 1 3/8" hollow, 6-spline shaft. 1 1/2" inlet, 1 1/4" outlet.	43 lbs.
9403P-540Q	86	82	600	Belt-driven, polypropylene pump with 1 3/8", 6-spline quick coupler shaft. 1 1/2" inlet, 1 1/4" outlet.	43 lbs.
9403P-540S	86	82	600	Belt-driven, polypropylene pump with 1" solid shaft. 1 1/2" inlet, 1 1/4" outlet.	43 lbs.
9403P-1000	86	82	1000	Belt-driven, polypropylene pump with 1 3/8" hollow, 21-spline shaft. 1 1/2" inlet, 1 1/4" outlet.	40 lbs.
9403P-1000L	86	82	1000	Belt-driven, polypropylene pump with 1 3/8" hollow, 20-spline shaft. 1 1/2" inlet, 1 1/4" outlet.	40 lbs.
9403P-1000S	86	82	1000	Belt-driven, polypropylene pump with 1" solid shaft. 1 1/2" inlet, 1 1/4" outlet.	40 lbs.
3430-0333	Seal and o-ring repair kit				4 oz.
3430-0478	Seal, o-ring, belt and gasket repair kit for 540 rpm drives				1 lb.
3430-0479	Seal, o-ring, belt and gasket repair kit for 1000 rpm drives				1 lb.
3430-0590	Life Guard® silicon carbide seal and o-ring kit				4 oz.

Life Guard® Silicon Carbide Seal - Add Suffix "B" - (i.e.: 9403C-540Q-B)

9600C Turbine Pump and PTO Adapters

Model Number	Max. GPM	Max. PSI	Max. RPM	Description	Estimated Weight Ea.
9600C	100	100	1200	High-capacity Turbine Pump made of cast iron with Valox® impeller, Viton lip seals and stainless steel 5/16" shaft and 1/4" key way.	26 lbs.
1320-0080			1200	1 1/4" Forged Steel PTO Adapter (20 Spline)	1 lb.
1320-0078			1200	1 3/8" Forged Steel PTO Adapter (21 Spline)	1 lb.
3430-0346	Torque Arm kit for 9600				2 lbs.
3430-0347	Seal and o-ring repair kit				1 lb.
0400-9600P	Valox impeller				1 lb.

The Spray Tech part number can be derived by adding the prefix 'HY' to the listed Hypro numbers.

New! Gas Engine-Driven Polypropylene Transfer Pumps



Model Number	Max. GPM	Max. PSI	Description	Estimated Weight Ea.
1542P-3SP	150	58	2" x 2" NPT self-priming polypropylene transfer pump with 3 vane impeller, powered by 5.5 hp PowerPro gas engine with low oil sensor.	46 lbs.
1542P-5SP	200	58	2" x 2" NPT self-priming polypropylene transfer pump with 5 vane impeller, powered by 6.5 hp PowerPro gas engine with low oil sensor.	50 lbs.
2549-0039	5.5 hp PowerPro gas engine with low oil sensor			42 lbs.
2549-0041	6.5 hp PowerPro gas engine with low oil sensor			42 lbs.
3430-0637	EPDM Seal Pump Head Kit for 1542P-3SP			4 oz.
3430-0648	EPDM Seal Pump Head Kit for 1542P-5SP			4 oz.
3430-0635	EPDM Seal Kit			4 oz.
3430-0660	Viton Seal Pump Head Kit for 1542P-3SP			4 oz.
3430-0661	Viton Seal Pump Head Kit for 1542P-5SP			4 oz.
3430-0659	Viton Seal Kit			4 oz.

Life Guard® Silicon Carbide Seal Kits

The Life Guard® silicon carbide seal lives up to its name by protecting your pump from seal failure. It lasts up to 8 times longer than ceramic seals when used in abrasive solutions. The silicon carbide surfaces work together to provide excellent thermal conductivity, making it last up to 21 times longer in dry run situations than ceramic seals. The Life Guard® silicon carbide seal comes standard in all stainless steel centrifugal pumps.



Part Number	For Pump Series/Model #	Size	Description	Estimated Weight Ea.
3430-0589	9200, 9300 and 9400 Cast and Stainless	5/8"	Mechanical seal and o-ring	4 oz.
3430-0593	9303P	5/8"	Mechanical seal, o-ring, gasket and washer for under acorn nut	4 oz.
3430-0601	9305C and 9305C-SP	5/8"	Mechanical seal and o-ring	4 oz.
3430-0590	All Poly Models	3/4"	Mechanical seal, o-ring, gasket and washer for under acorn nut	4 oz.
3430-0604	9307 Series	1 1/8"	Mechanical seal, o-ring and gasket	4 oz.
3430-0646	9205 Models	3/4"	Mechanical seal and o-ring	4 oz.

12 Volt Clutch



Part Number	Shaft Size	Pulley Type	Max. HP	Max. RPM	For Pump Model	Estimated Weight Ea.
2526-0011	7/8"	5.25"-A	30	5000	9203P, 9253P-C, 9500P-S, 9205C, 9205C-SP	8 lbs.
3430-0592	5/8"	5.00" Double Groove-A	30	5000	9202C, 9203C, 9204C, 9203C-R, 9262C-C, 9263C-C, 9263C-CR, 9203C-SP, 9262S-C, 9263S-C, 9263S-CR, 9263C-C-SP, 9263C-CR-SP	8.5 lbs.

The Spray Tech part number can be derived by adding the prefix 'HY' to the listed Hypro numbers.

Roller Pumps and Accessories

1200 Series Roller Pump



Model Number	Max. GPM	Max. PSI	Max. RPM	Description	Estimated Weight Ea.
1200C	74.0	150	800	Cast iron 4-roller pump with Super Rollers, Buna-N seals, 1½" NPT ports, and a 1" solid shaft.	32 lbs.
3430-0207	Locking collar kit for model 1200C				8 oz.

Viton seals - Add Suffix "Q" - (i.e.: 1200C-Q)
Reverse rotation†† - Add Suffix "R" - (i.e.: 1200C-R)

1500 Series Roller Pumps



Model Number	Max. GPM	Max. PSI	Max. RPM	Description	Estimated Weight Ea.
1502C	62.1	150	1000	Cast iron 6-roller pump with Super Rollers, Buna-N seals, 1½" NPT ports, and 5/16" solid shaft.	30 lbs.
1502N	62.1	150	1000	Ni-Resist 6-roller pump with Super Rollers, Buna-N seals, 1½" NPT ports, and 5/16" solid shaft.	30 lbs.
1502XL	62.1	150	1000	SilverCast 6-roller pump with Super Rollers, Viton seals, 1½" NPT ports, and 5/16" solid shaft.	30 lbs.

Teflon rollers† - Add Suffix "T2" - (i.e.: 1502C-T2)
Buna-N seals - Add Suffix "M" - (i.e.: 1502XL-M)
Viton seals - Add Suffix "Q" - (i.e.: 1502C-Q)
Reverse rotation†† - Add Suffix "R" - (i.e.: 1502C-R)

1700 Series Roller Pumps



Model Number	Max. GPM	Max. PSI	Max. RPM	Description	Estimated Weight Ea.
1700C	45.0	200	1000	Cast iron 5-roller pump with Super Rollers, Viton seals, 1" NPT ports, and 5/16" solid shaft.	19 lbs.
1700N	45.0	200	1000	Ni-Resist 5-roller pump with Super Rollers, Viton seals, 1" NPT ports, and 5/16" solid shaft.	19 lbs.
1700XL	45.0	200	1000	SilverCast 5-roller pump with Super Rollers, Viton seals, 1" NPT ports, and 5/16" solid shaft.	19 lbs.

Teflon rollers† - Add Suffix "T2" - (i.e.: 1700C-T2)
Buna-N seals - Add Suffix "M" - (i.e.: 1700C-M)
Reverse rotation†† - Add Suffix "R" - (i.e.: 1700C-R)

† The maximum recommended operating pressure is 100 psi for pumps fitted with Buna-N or Teflon rollers.
 †† Rotation, clockwise or counterclockwise, is determined when looking at the shaft end of the pump. Standard rotation for all roller pumps is counterclockwise, except 4000 series.

All Hypro roller pumps need either an adapter or quick coupler

The Spray Tech part number can be derived by adding the prefix 'HY' to the listed Hypro numbers.



6500 Series Roller Pumps



Model Number	Max. GPM	Max. PSI	Max. RPM	Description	Estimated Weight Ea.
6500C	21.8	300	1200	Cast iron 6-roller pump with Super Rollers, Super Rotor, Viton seals, 3/4" NPT ports, and 5/8" solid shaft.	9 lbs.
6500N	21.8	300	1200	Ni-Resist 6-roller pump with Super Rollers, Super Rotor, Viton seals, 3/4" NPT ports, and 5/8" solid shaft.	9 lbs.
6500XL	21.8	300	1200	SilverCast 6-roller pump with Super Rollers, Super Rotor, Viton seals, 3/4" NPT ports, and 5/8" solid shaft.	9 lbs.

Buna-N rollers[†] - Add Suffix "F" - (i.e.: 6500C-F)
Teflon rollers[†] - Add Suffix "T2" - (i.e.: 6500C-T2)

Buna-N seals - Add Suffix "M" - (i.e.: 6500C-M)
Reverse rotation^{††} - Add Suffix "R" - (i.e.: 6500C-R)
Metallic Rotor - Add Suffix "A" - (i.e.: 6500C-A)

7560 Series Roller Pumps



Model Number	Max. GPM	Max. PSI	Max. RPM	Description	Estimated Weight Ea.
7560C	22.5	300	1000	Cast iron 8-roller pump with Super Rollers, Super Rotor, Viton seals, 3/4" NPT ports, and 15/16" solid shaft.	13 lbs.
7560N	22.5	300	1000	Ni-Resist 8-roller pump with Super Rollers, Super Rotor, Viton seals, 3/4" NPT ports, and 15/16" solid shaft.	13 lbs.
7560XL	22.5	300	1000	SilverCast 8-roller pump with Super Rollers, Super Rotor, Viton seals, 3/4" NPT ports, and 15/16" solid shaft.	13 lbs.
7560C-GM30	20.1	300	1000	Same as 7560C, coupled to an SAE 2 bolt A flanged, low speed, high torque hydraulic motor. 3 cubic inch motor displacement, 12 gpm hydraulic flow max.	33 lbs.
7560N-GM30	20.1	300	1000	Same as 7560N, coupled to an SAE 2 bolt A flanged, low speed, high torque hydraulic motor. 3 cubic inch motor displacement, 12 gpm hydraulic flow max.	33 lbs.
7560XL-GM30	20.1	300	1000	Same as 7560XL, coupled to an SAE 2 bolt A flanged, low speed, high torque hydraulic motor. 3 cubic inch motor displacement, 12 gpm hydraulic flow max.	33 lbs.

Buna-N rollers[†] - Add Suffix "F" - (i.e.: 7560C-F)
Teflon rollers[†] - Add Suffix "T2" - (i.e.: 7560C-T2)

Buna-N seals - Add Suffix "M" - (i.e.: 7560C-M)
Reverse rotation^{††} - Add Suffix "R" - (i.e.: 7560C-R)
Metallic Rotor - Add Suffix "A" - (i.e.: 7560C-A)

7700 Series Roller Pumps



Model Number	Max. GPM	Max. PSI	Max. RPM	Description	Estimated Weight Ea.
7700C	22.1	200	800	Cast iron 7-roller pump with Super Rollers, Super Rotor, Viton seals, 3/4" NPT ports, and 15/16" solid shaft.	14 lbs.
7700N	22.1	200	800	Ni-Resist 7-roller pump with Super Rollers, Super Rotor, Viton seals, 3/4" NPT ports, and 15/16" solid shaft.	14 lbs.
7700XL	22.1	200	800	SilverCast 7-roller pump with Super Rollers, Super Rotor, Viton seals, 3/4" NPT ports, and 15/16" solid shaft.	14 lbs.

Buna-N rollers[†] - Add Suffix "F" - (i.e.: 7700C-F)
Teflon rollers[†] - Add Suffix "T2" - (i.e.: 7700C-T2)

Buna-N seals - Add Suffix "M" - (i.e.: 7700C-M)
Reverse rotation^{††} - Add Suffix "R" - (i.e.: 7700C-R)
Metallic Rotor - Add Suffix "A" - (i.e.: 7700C-A)

The Spray Tech part number can be derived by adding the prefix 'HY' to the listed Hypro numbers.

4001 Series Roller Pumps



Model Number	Max. GPM	Max. PSI	Max. RPM	Description	Estimated Weight Ea.
4001C-A	9.1	150	1800	Cast iron 4-roller pump with Super Rollers, Viton seals, 3/4" NPT ports, and 5/8" solid shaft.	5 lbs.
4001C-AH	9.1	150	1800	4001C pump with 1/2" hollow shaft.	5 lbs.
4001N-A	9.1	150	1800	Ni-Resist 4-roller pump with Super Rollers, Viton seals; 3/4" NPT ports, and 5/8" solid shaft.	5 lbs.
4001N-AH	9.1	150	1800	4001N pump with 1/2" hollow shaft.	5 lbs.
4001XL-A	9.1	150	1800	SilverCast 4-roller pump with Super Rollers Viton seals, 3/4" NPT ports, and 5/8" solid shaft.	5 lbs.
4001XL-AH	9.1	150	1800	SilverCast 4001XL pump with 1/2" hollow shaft.	5 lbs.

Teflon rollers - Add Suffix "T2" - (i.e.: 4001C-T2)

Buna-N rollers - Add Suffix "G" - (i.e.: 4001C-G)

Buna-N seals - Add Suffix "M" - (i.e.: 4001C-M)

Reverse rotation* - Add Suffix "R" - (i.e.: 4001C-R)

4001 Series Roller Pumps with 12 Volt DC motor



Model Number	Max. GPM	Max. PSI	Max. RPM	Description	Estimated Weight Ea.
4001N-AEH	10.4	30	1900	12 Volt DC motor-driven, Ni-resist, 4-roller pump with Super Rollers, Viton seals, 3/4" NPT ports, 1/2" hollow shaft.	18 lbs.
4001N-AE2H	9.9	50	1600	12 Volt DC motor-driven, Ni-resist, 4-roller pump with Super Rollers, Viton seals, 3/4" NPT ports, 1/2" hollow shaft. Designed for higher pressures.	18 lbs.
4001XL-AEH	10.4	30	1900	12 Volt DC motor-driven, Silver Cast, 4-roller pump with Super Rollers, Viton seals, 3/4" NPT ports, 1/2" hollow shaft.	18 lbs.
4001XL-AE2H	9.9	50	1600	12 Volt DC motor-driven, Silver Cast, 4-roller pump with Super Rollers, Viton seals, 3/4" NPT ports, 1/2" hollow shaft. Designed for higher pressures.	18 lbs.

Teflon rollers - Add Suffix "T2" - (i.e.: 4001N-AEHT2)

Buna-N rollers - Add Suffix "G" - (i.e.: 4001N-AEGH)

Buna-N seals - Add Suffix "M" - (i.e.: 4001N-AEHM)

Reverse rotation* - Add Suffix "R" - (i.e.: 4001N-AEHR)

* Rotation, clockwise or counterclockwise, is determined when looking at the shaft end of the pump. Standard rotation for all Series 4000 roller pumps is clockwise.

Consult performance tables for operating pressure and volume.

All Hypro roller pumps need either an adapter or quick coupler

The Spray Tech part number can be derived by adding the prefix 'HY' to the listed Hypro numbers.

4101 Series Roller Pumps



Model Number	Max. GPM	Max. PSI	Max. RPM	Description	Estimated Weight Ea.
4101C-A	7.2	150	2600	Cast iron 4-roller pump with Super Rollers, Viton seals, 1/4" NPT ports, and 5/8" solid shaft.	5 lbs.
4101C-AH	7.2	150	2600	4101C pump with 1/2" hollow shaft.	5 lbs.
4101C-AD	7.2	150	2600	4101C pump with 5/8" hollow shaft adapter 1320-0016 installed.	6 lbs.
4101N-A	7.2	150	2600	Ni-Resist 4-roller pump with Super Rollers, Viton seals, 1/4" NPT ports, and 5/8" solid shaft.	6 lbs.
4101N-AH	7.2	150	2600	4101N pump with 1/2" hollow shaft.	5 lbs.
4101N-AD	7.2	150	2600	4101N pump with 5/8" hollow shaft adapter 1320-0016 installed.	6 lbs.
4101XL-A	7.2	150	2600	SilverCast 4-roller pump with Super Rollers, Viton seals, 1/4" NPT ports, and 5/8" solid shaft.	5 lbs.
4101XL-AH	7.2	150	2600	SilverCast 4101XL pump with 1/2" hollow shaft.	5 lbs.
4101XL-AD	7.2	150	2600	SilverCast 4101XL pump with 5/8" hollow shaft adapter 1320-0016 installed.	6 lbs.

Teflon rollers - Add Suffix "T2" - (i.e.: 4101C-T2)

Buna-N rollers - Add Suffix "G" - (i.e.: 4101C-G)

Buna-N seals - Add Suffix "M" - (i.e.: 4101C-M)

Reverse rotation - Add Suffix "R" - (i.e.: 4101C-R)

4101 Series Roller Pumps with 12 Volt DC motor



Model Number	Max. GPM	Max. PSI	Max. RPM	Description	Estimated Weight Ea.
4101N-AEH	7.5	50	1900	12 Volt DC motor-driven, Ni-Resist, 4-roller pump with Super Rollers, Viton seals, 1/4" ports, 1/2" hollow shaft.	16 lbs.
4101N-AE2H	5.9	90	1600	12 Volt DC motor-driven, Ni-Resist, 4-roller pump with Super Rollers, Viton seals, 1/4" ports, 1/2" hollow shaft. Designed for higher pressures.	16 lbs.
4101XL-AEH	7.5	50	1900	SilverCast, 12 Volt DC motor-driven, 4-roller pump with Super Rollers, Viton seals, 1/4" ports, 1/2" hollow shaft.	18 lbs.
4101XL-AE2H	5.9	90	1600	SilverCast, 12 Volt DC motor-driven, 4-roller pump with Super Rollers, Viton seals, 1/4" ports, 1/2" hollow shaft. Designed for higher pressures.	18 lbs.

Teflon rollers - Add Suffix "T2" - (i.e.: 4101N-AEHT2)



Buna-N rollers - Add Suffix "G" - (i.e.: 4101N-AEGH)

Buna-N seals - Add Suffix "M" - (i.e.: 4101N-AEHM)

Reverse rotation - Add Suffix "R" - (i.e.: 4101N-AEHR)



The Spray Tech part number can be derived by adding the prefix 'HY' to the listed Hypro numbers.

Adapters for PTO and Gas Engine Adaption (Female to Female)

	Part Number	PTO (I.D.)	Pump End (I.D.)	Material	RPM	For Pump Series
	1320-0015	3/4"	5/8"	steel	*	4000, 6500
	1320-0016	5/8"	5/8"	steel	*	4000, 6500
	1320-0022	1 1/8" (6 spline)	5/8"	die cast	540	6500
	1320-0033	1 1/8" (6 spline)	15/16"	die cast	540	1500, 1700, 7560, 7700
	1320-0038	1 3/8" (21 spline)	15/16"	die cast	1000	1500, 1700, 7560
	1320-0053	1 3/8" (21 spline)	5/8"	die cast	1000	4000, 6500
	1320-0054	3/4"	15/16"	die cast	*	1500, 1700, 7560, 7700
	1320-0059	1 1/8" (6 spline)	1"	die cast	540	1200
	1320-0076	1 1/8" (6 spline)	15/16"	forged steel	540	1500, 1700, 7560, 7700
	1320-0077	1 1/8" (6 spline)	5/8"	forged steel	540	6500
	1320-0078	1 3/8" (21 spline)	15/16"	forged steel	1000	1500, 1700, 7560
	1320-0079	1 3/8" (21 spline)	5/8"	forged steel	1000	4000, 6500
	1320-0080	1 3/4" (20 spline)	15/16"	forged steel	1000	1500, 1700, 7560
	1320-0081	1 1/8" (6 spline)	1"	forged steel	540	1200

* Refer to the recommended pump rpm.

Quick Couplers (Female to Female)

	Part Number	PTO (I.D.)	Pump End (I.D.)	Material	RPM	For Pump Series
	1321-0006	1 1/8" (6 spline)	5/8"	die cast	540	6500
	1321-0007	1 1/8" (6 spline)	15/16"	die cast	540	1500, 1700, 7560, 7700
	1321-0008	1 3/8" (21 spline)	5/8"	die cast	1000	4000, 6500
	1321-0009	1 3/8" (21 spline)	15/16"	die cast	1000	1500, 1700, 7560
	1321-0012	1 1/8" (multi-speed)	5/8"	die cast	540/1000	4000, 6500
	1321-0013	1 1/8" (multi-speed)	15/16"	die cast	540/1000	1500, 1700, 7560, 7700
	1323-0072	1 1/8" (6 spline)	15/16"	forged steel	540	1500, 1700, 7560, 7700
	1323-0073	1 3/8" (21 spline)	15/16"	forged steel	1000	1500, 1700, 7560
	1323-0074	1 1/8" (6 spline)	5/8"	forged steel	540	6500
	1323-0075	1 3/8" (21 spline)	5/8"	forged steel	1000	4000, 6500
	1323-0076	1 1/8" (multi-speed)	15/16"	forged steel	540/1000	1500, 1700, 7560, 7700
	1323-0077	1 1/8" (multi-speed)	5/8"	forged steel	540/1000	4000, 6500

Speed Controller for Pressure and Output of 12V Motor-Driven Pumps

Part Number	Description	Estimated Weight Ea.
2530-0057	<ul style="list-style-type: none"> 12-volt pulse-width modulated motor speed controller Quick-disconnect motor cables (sheathed) in 20-ft. lengths 8-foot, 10-gauge power leads with ring terminals 0-60 psi glycerin-filled gauge Solenoid/boom circuit <p>Use with 4101N-AEH, 4101XL-AEH, 4001N-AEH and 4001XL-AEH 12-volt pumps and eliminate the need for a pressure relief valve in your pumping system. Simply dial your required pressure by adjusting the speed of the motor.</p>	5 lbs.

Torque Arm Kit (pump not included)

Part Number	Material	RPM	For Pump Series	Estimated Weight Ea.
3430-0540	steel	540/1000	1700, 6500, 7560, 7700 and 9600	3 lbs.

The Spray Tech part number can be derived by adding the prefix 'HY' to the listed Hypro numbers.



Piston Pumps

5200 Series Big Twin® Piston Pumps



Model Number	Max. GPM	Max. PSI	Max. RPM	Description	Estimated Weight Ea.
5206C	8.0	600	800	Cast iron pump with leather cups and Ni-Resist sleeves, 1" solid shaft with base, 3/4" ports, 140°F maximum temp.	18 lbs.
5206C-H	8.0	400	800	Cast iron pump with leather cups and Ni-Resist sleeves, 1 1/2" hollow shaft w/base, 3/4" ports, 140°F maximum temp.	18 lbs.
5210C	10.0	400	600	Cast iron pump with leather cups and Ni-Resist sleeves, 1" solid shaft with base 3/4", ports, 140°F maximum temp.	18 lbs.
5210C-H	10.0	400	600	Cast iron pump with leather cups and Ni-Resist sleeves, 1 1/2" hollow shaft w/base, 3/4" ports, 140°F maximum temp.	18 lbs.
3430-0037	Leather cup kit.				3 oz.

Fabric Cups - Add Suffix "F" - (ie.: 5206C-F) -
Buna-N Cups - Add Suffix "R" - (ie.: 5206C-R)

5300 Series Small Twin® Piston Pumps with Solid Shaft



Model Number	Max. GPM	Max. PSI	Max. RPM	Description	Estimated Weight Ea.
5315C-X	1.5	500	1800	Cast iron pumps with base, 5/8" OD solid shaft, 1/2" NPT ports, 140° F maximum temp.	10 lbs.
5315C-RX				Cup material: X (leather), RX (Buna-N), CX (Teflon).	
5315C-CX				Cup material: X (leather), RX (Buna-N), CX (Teflon).	
5320C-X	2.2	500	1800	Cast iron pumps with base, 5/8" OD solid shaft, 1/2" NPT ports, 140° F maximum temp.	10 lbs.
5320C-RX				Cup material: X (leather), RX (Buna-N), CX (Teflon).	
5320C-CX				Cup material: X (leather), RX (Buna-N), CX (Teflon).	
5325C-X	2.5	500	1800	Cast iron pumps with base, 5/8" OD solid shaft, 1/2" NPT ports, 140° F maximum temp.	10 lbs.
5325C-RX				Cup material: X (leather), RX (Buna-N), CX (Teflon).	
5325C-CX				Cup material: X (leather), RX (Buna-N), CX (Teflon).	
5330C-X	3.0	500	1800	Cast iron pumps with base, 5/8" OD solid shaft, 1/2" NPT ports, 140°F maximum temp.	10 lbs.
5330C-RX				Cup material: X (leather), RX (Buna-N), CX (Teflon).	
5330C-CX				Cup material: X (leather), RX (Buna-N), CX (Teflon).	

Injector Head - Add Suffix "D" - (ie.: 5320C-DRX)

5300 Series Small Twin® Piston Pumps with Hollow Shaft



Model Number	Max. GPM	Max. PSI	Max. RPM	Description	Estimated Weight Ea.
5315C-HX	1.5	500	1800	Cast iron pumps with torque arm, 5/8" ID hollow shaft, 1/2" NPT ports, 140°F maximum temp. Cup material:	10 lbs.
5315C-HRX				HX (leather), HRX (Buna-N), CHX (Teflon).	
5315C-CHX				HX (leather), HRX (Buna-N), CHX (Teflon).	
5320C-HX	2.2	500	1800	Cast iron pumps with torque arm, 5/8" ID hollow shaft, 1/2" NPT ports, 140°F maximum temp. Cup material:	10 lbs.
5320C-HRX				HX (leather), HRX (Buna-N), CHX (Teflon).	
5320C-CHX				HX (leather), HRX (Buna-N), CHX (Teflon).	
5325C-HX	2.5	500	1800	Cast iron pumps with torque arm, 5/8" ID hollow shaft, 1/2" NPT ports, 140°F maximum temp. Cup material:	10 lbs.
5325C-HRX				HX (leather), HRX (Buna-N), CHX (Teflon).	
5325C-CHX				HX (leather), HRX (Buna-N), CHX (Teflon).	
5330C-HX	3.0	500	1800	Cast iron pumps with torque arm, 5/8" ID hollow shaft, 1/2" NPT ports, 140°F maximum temp. Cup material:	10 lbs.
5330C-HRX				HX (leather), HRX (Buna-N), CHX (Teflon).	
5330C-CHX				HX (leather), HRX (Buna-N), CHX (Teflon).	

Injector Head - Add Suffix "D" - (ie.: 5320C-DHRX)

The Spray Tech part number can be derived by adding the prefix 'HY' to the listed Hypro numbers.



5300 Series Small Twin® Plunger Pumps with Solid Shaft

	Model Number	Max. GPM	Max. PSI	Max. RPM	Description	Estimated Weight Ea.
	5321C	2.2	1000	1800	Cast iron pumps with base and Buna-N seals, 5/8" OD solid shaft, 1/2" NPT ports, 180°F maximum temp. Plunger material: 5321 (stainless steel), 5322 (ceramic).	11 lbs.
	5322C	2.2	1000	1800		11 lbs.
	5324C	2.9	800	1800	Cast iron pumps with base and Buna-N seals, 5/8" OD solid shaft, 1/2" NPT ports, 140°F maximum temp. Plunger material: stainless steel.	11 lbs.

Injector Head - Add Suffix "D" - (i.e.: 5321C-D)

5300 Series Small Twin® Plunger Pumps with Hollow Shaft

	Model Number	Max. GPM	Max. PSI	Max. RPM	Description	Estimated Weight Ea.
	5321C-H	2.2	1000	1800	Cast iron pumps with torque arm and Buna-N seals, 5/8" ID hollow shaft, 1/2" NPT ports, 180°F maximum temp. Plunger material: 5321 (stainless steel), 5322 (ceramic).	11 lbs.
	5322C-H	2.2	1000	1800		10 lbs.
	5324C-H	2.9	800	1800	Cast iron pumps with torque arm and Buna-N seals, 5/8" ID hollow shaft, 1/2" NPT ports, 140°F maximum temp. Plunger material: stainless steel.	11 lbs.

Injector Head - Add Suffix "D" - (i.e.: 5321C-D)

The Spray Tech part number can be derived by adding the prefix 'HY' to the listed Hypro numbers.

Series 4000

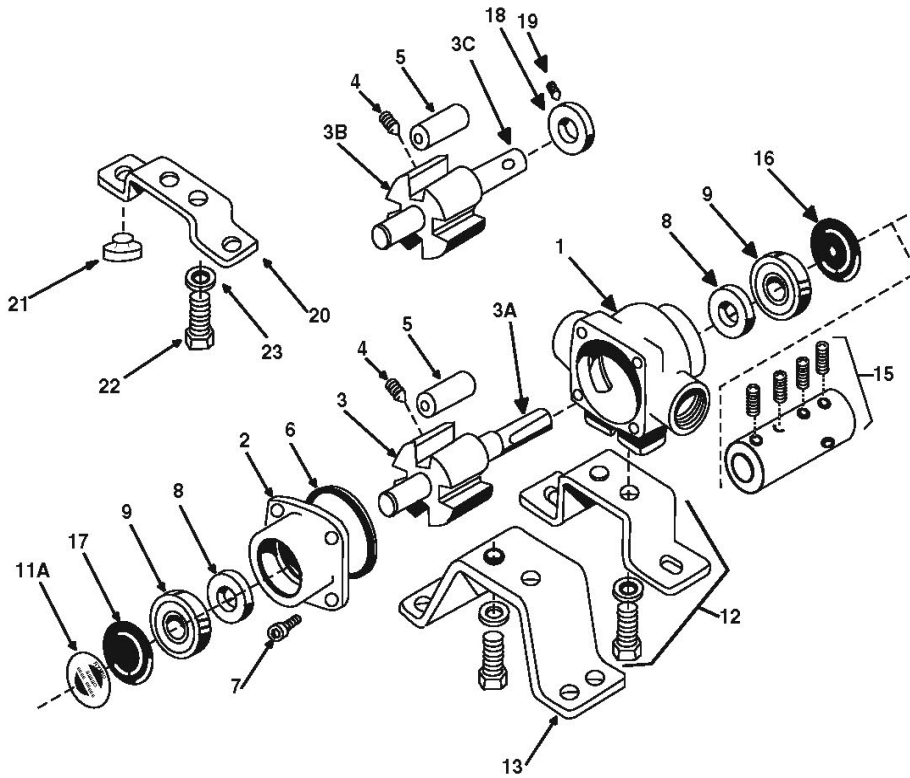

Ref. No.	Qty. Req'd.	Part Number	Description
1	1	0100-4001C	Body (Cast Iron) with Std. Seal (4001)
1	1	0100-4101C	Body (Cast Iron) with Std. Seal (4101)
1	1	0100-4001N	Body (Ni-Resist) with Std. Seal (4001)
1	1	0100-4101N	Body (Ni-Resist) with Std. Seal (4101)
1	1	0100-4001X	Body (SilverCast) with Std. Seal (4001)
1	1	0100-4101X	Body (SilverCast) with Std. Seal (4101)
2	1	0200-4001C	Endplate (Cast Iron) with Std. Seal (4001)
2	1	0200-4101C	Endplate (Cast Iron) with Std. Seal (4101)
2	1	0200-4001N	Endplate (Ni-Resist) with Std. Seal (4001)
2	1	0200-4101N	Endplate (Ni-Resist) with Std. Seal (4101)
2	1	0200-4001X	Endplate (SilverCast) with Std. Seal (4001)
2	1	0200-4101X	Endplate (SilverCast) with Std. Seal (4101)
3	1	0300-4001C	Rotor (Cast Iron) & Shaft Assembly (4001)
3	1	0300-4101C	Rotor (Cast Iron) & Shaft Assembly (4101)
3	1	0300-4001N	Rotor (Ni-Resist) & Shaft Assembly (4001)
3	1	0300-4101N	Rotor (Ni-Resist) & Shaft Assembly (4101)
3	1	0300-4001X	Rotor (SilverCast) & Shaft Assembly (4001)
3	1	0300-4101X	Rotor (SilverCast) & Shaft Assembly (4101)
3A	1	0500-6600	Shaft Only
3B	1	0301-4001N	Rotor (Ni-Resist) & Shaft Assembly (4001)
3B	1	0301-4101N	Rotor (Ni-Resist) & Shaft Assembly (4101)
3B	1	0301-4101X	Rotor (SilverCast) & Shaft Assembly (4101)
3B	1	0301-4001X	Rotor (SilverCast) & Shaft Assembly (4001)
3C	1	0550-4001	Shaft Only (Hollow Shaft)
4	1	2230-0002	Rotor Set Screw
4	1	2230-0016	Rotor Set Screw (SilverCast Only)
5	4	1005-0002	Super Rollers (Std.)
5	4	1002-0002	Polypropylene Rollers (Optional)
5	4	1001-0002	Buna-N Rollers (Optional)
5	4	1055-0002	Teflon Rollers (Optional)

Ref. No.	Qty. Req'd.	Part Number	Description
6	1	1720-0104	O-Ring Gasket for Endplate
7	4	2220-0018	Endplate Screw
8	2	2107-0002	Viton Seal (Std.)
8	2	2102-0001	Buna-N Seal (Optional)
9	2	2000-0010	Ball Bearing (High temp. grease)
11A	1		Name Plate (Specify pump model #)
12	1	3420-0024	Base Kit — Includes: 1 Base, 2 Bolts, and 2 Lock washers for mounting pump to electric motors with 3-1/2" shaft centerline
13	1	3420-0025	Base Kit — Includes: 1 Base, 2 Bolts, and 2 Lock Washers for mounting pump to electric motors/gas engines with 4-3/16" shaft centerlines
15	1 kit	1320-0016	Adapter with 4 set screws for gas engine mount (5/8" x 5/8")
15	1 kit	1320-0015	Adapter (5/8" x 3/4")
16	1	2300-0023	Shaft Bearing Cover
17	1	2300-0021	Bearing Cover
18	1	1420-0001	Locking Collar
19	1	2230-0001	Set Screw
20	1	1510-0054	Base
21	2	1450-0003	Bumper
22	2	2210-0003	Bolt
23	2	2260-0002	Lock Washer

Repair Parts Kit No. 3430-0390 Consists of: (4) Ref. 5 Super Rollers, (1) Ref. 6 O-Ring Gasket, (2) Ref. 8 Viton Seals.

Repair Parts Kit No. 3430-0158 Consists of: (4) Ref. 5 Polypropylene Rollers, (1) Ref. 6 O-Ring Gasket, (2) Ref. 8 Viton Seals.

The Spray Tech part number can be derived by adding the prefix 'HY' to the listed Hypro numbers.

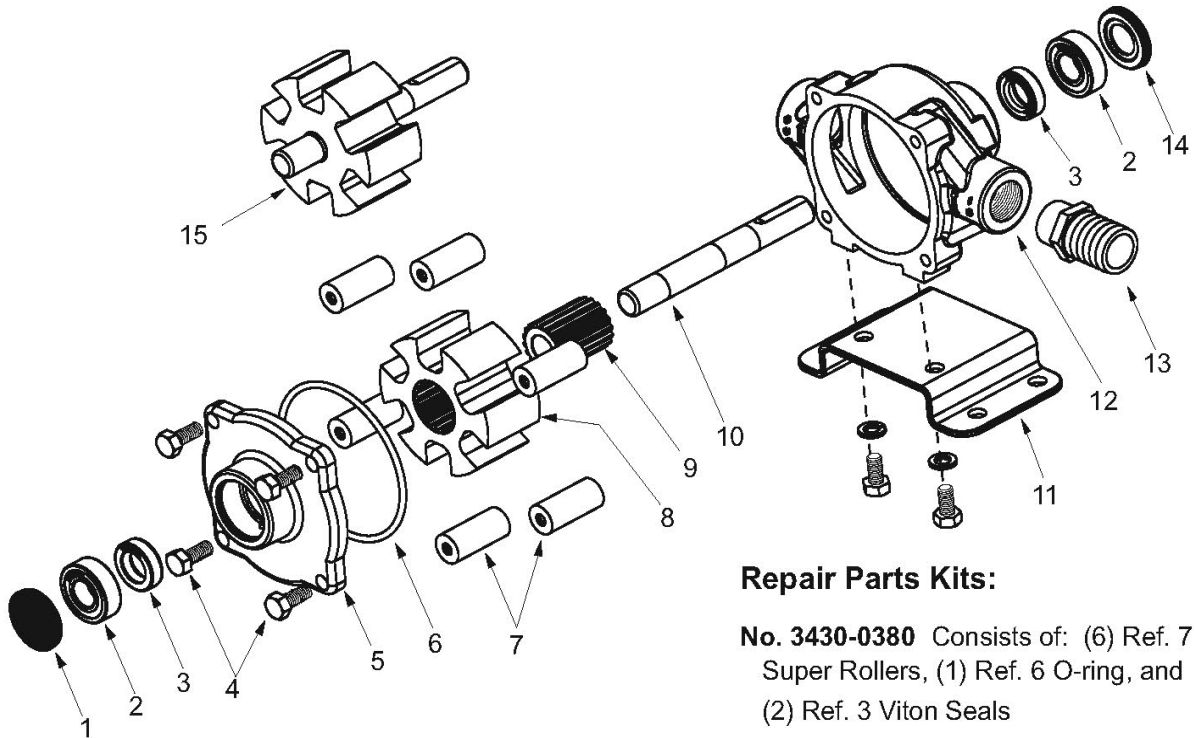

Repair Parts Kits:

No. 3430-0380 Consists of: (6) Ref. 7 Super Rollers, (1) Ref. 6 O-ring, and (2) Ref. 3 Viton Seals

No. 3430-0175 Consists of: (6) Ref. 7 Polypropylene Rollers, (1) Ref. 6 O-ring, and (2) Ref. 3 Viton Seals

No. 3430-0621 Consists of: (1) Ref. 8 Phenolic Rotor, (1) Ref. 9 Metal Insert, and (1) Ref. 10 Shaft

Ref. No.	Qty. Req'd.	Part No.	Description
1	1	2300-0021	Bearing Cover
2	2	2000-0010	Sealed Ball Bearing
3	2	2107-0002	Viton Seal (Standard)
3	2	2102-0001	Buna-N Seal (Optional)
4	4	2210-0004	Bolts
5	1	0200-6600C	Endplate (Cast Iron) with seal
5	1	0200-6600N	Endplate (Ni-Resist) with seal
5	1	0200-6600X	Endplate (SilverCast) with seal
6	1	1720-0008	O-ring Gasket for Endplate
7	6	1005-0004	Super Roller (Standard)
7	6	1002-0004	Polypropylene Roller (Optional)
7	6	1052-0004	Buna-N Roller (Optional)
7	6	1055-0004	Teflon Roller (Optional)
8	1	0401-6500P	Phenolic Rotor (Standard)

Ref. No.	Qty. Req'd.	Part No.	Description
9	1	1201-0018	Metal insert
10	1	0500-6500	Shaft
11	1 kit	3420-0023	Base Kit - Includes: (1) Base, (2) Bolts and (2) Washers
12	1	0100-6600C	Body (Cast Iron) with seal
12	1	0100-6600N	Body (Ni-Resist) with seal
12	1	0100-6600X	Body (SilverCast) with seal
13	1	2404-0052	1" Hose Barb
14	1	2300-0023	Shaft Bearing Cover
15	1	N/A	Metal Rotor Assembly: Replaced by Kit No. 3430-0621 (Phenolic Rotor Assembly)

The Spray Tech part number can be derived by adding the prefix 'HY' to the listed Hypro numbers.

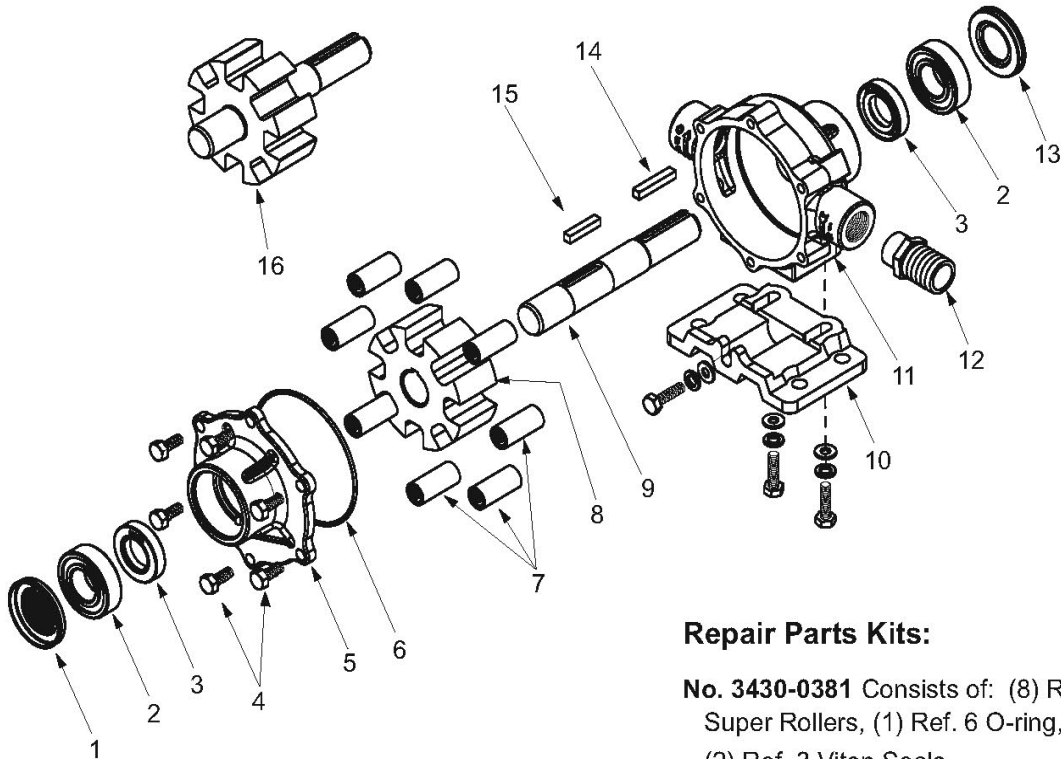

Repair Parts Kits:

No. 3430-0381 Consists of: (8) Ref. 7 Super Rollers, (1) Ref. 6 O-ring, and (2) Ref. 3 Viton Seals

No. 3430-0167 Consists of: (8) Ref. 7 Polypropylene Rollers, (1) Ref. 6 O-ring, and (2) Ref. 3 Viton Seals

No. 3430-0622 Consists of: (1) Ref. 8 Phenolic Rotor, (1) Ref. 9 Shaft, and (1) Ref. 15 Key

Ref. No.	Qty. Req'd.	Part No.	Description
1	1	2300-0020	Bearing Cover
2	2	2008-0001	Sealed Ball Bearing
3	2	2112-0003	Viton Seal (Standard)
3	2	2112-0001	Buna-N Seal (Optional)
4	6	2210-0004	Bolts
5	1	0204-7500C	Endplate (Cast Iron) with seal
5	1	0204-7500N	Endplate (Ni-Resist) with seal
5	1	0204-7500X	Endplate (SilverCast) with seal
6	1	1720-0014	O-ring Gasket for Endplate
7	8	1005-0004	Super Roller (Standard)
7	8	1002-0004	Polypropylene Roller (Optional)
7	8	1052-0004	Buna-N Roller (Optional)
7	8	1055-0004	Teflon Roller (Optional)

Ref. No.	Qty. Req'd.	Part No.	Description
8	1	0403-7500P	Phenolic (Standard)
9	1	0510-7500	Shaft (416 Stainless)
10	1 kit	3420-0003	Base Kit - Includes: (1) Base, (3) Bolts and (3) Washers
11	1	0104-7500C	Body (Cast Iron) with seal
11	1	0104-7500N	Body (Ni-Resist) with seal
11	1	0104-7500X	Body (SilverCast) with seal
12	1	2404-0052	1" Hose Barb
13	1	2300-0022	Shaft Bearing Cover
14	1	1610-0005	Key
15	1	1610-0059	Key (Stainless Steel)
16	1	N/A	Metal Rotor Assembly. Use Kit No. 3430-0622 (Phenolic rotor)

The Spray Tech part number can be derived by adding the prefix 'HY' to the listed Hypro numbers.

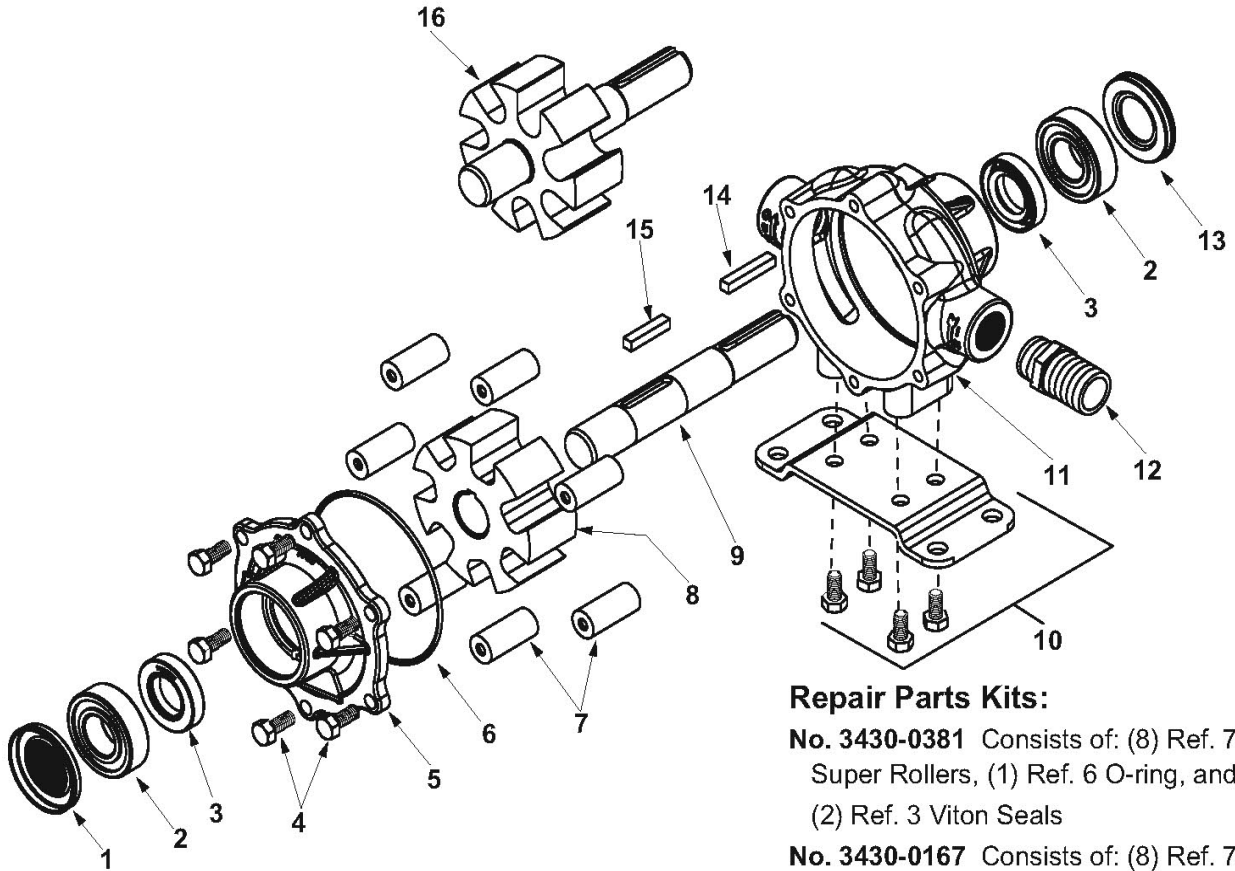

Repair Parts Kits:

No. 3430-0381 Consists of: (8) Ref. 7 Super Rollers, (1) Ref. 6 O-ring, and (2) Ref. 3 Viton Seals

No. 3430-0167 Consists of: (8) Ref. 7 Polypropylene Rollers, (1) Ref. 6 O-ring, and (2) Ref. 3 Viton Seals

No. 3430-0623 Consists of: (1) Ref. 8 Phenolic rotor, (1) Ref. 9 Shaft, and (1) Ref. 15 Key

Ref. No.	Qty. Req'd.	Part No.	Description
1	1	2300-0020	Bearing Cover
2	2	2008-0001	Sealed Ball Bearing
3	2	2112-0003	Viton Seal (Standard)
3	2	2112-0001	Buna-N Seal (Optional)
4	6	2210-0004	Bolts
5	1	0200-7700C	Endplate (Cast Iron) with seal
5	1	0200-7700N	Endplate (Ni-Resist) with seal
5	1	0200-7700X	Endplate (SilverCast) with seal
6	1	1720-0014	O-ring Gasket for Endplate
7	7	1005-0004	Super Roller (Standard)
7	7	1002-0004	Polypropylene Roller (Optional)
7	7	1052-0004	Buna-N Roller (Optional)
7	7	1055-0004	Teflon Roller (Optional)

Ref. No.	Qty. Req'd.	Part No.	Description
8	1	0401-7700P	Phenolic (Standard)
9	1	0510-7500	Shaft (416 Stainless)
10	1 kit	3420-0010	Base Kit - Includes: (1) Base, (4) Bolts
11	1	0100-7700C	Body (Cast Iron) with seal
11	1	0100-7700N	Body (Ni-Resist) with seal
11	1	0100-7700X	Body (SilverCast) with seal
12	1	2404-0052	1" Hose Barb
13	1	2300-0022	Shaft Bearing Cover
14	1	1610-0005	Key
15	1	1610-0059	Key (Stainless Steel)
16	1	N/A	Metal Rotor Assembly - Replaced by Kit No. 3430-0623 (Phenolic rotor)

The Spray Tech part number can be derived by adding the prefix 'HY' to the listed Hypro numbers.

Models 1700C, 1700N, and 1700XL

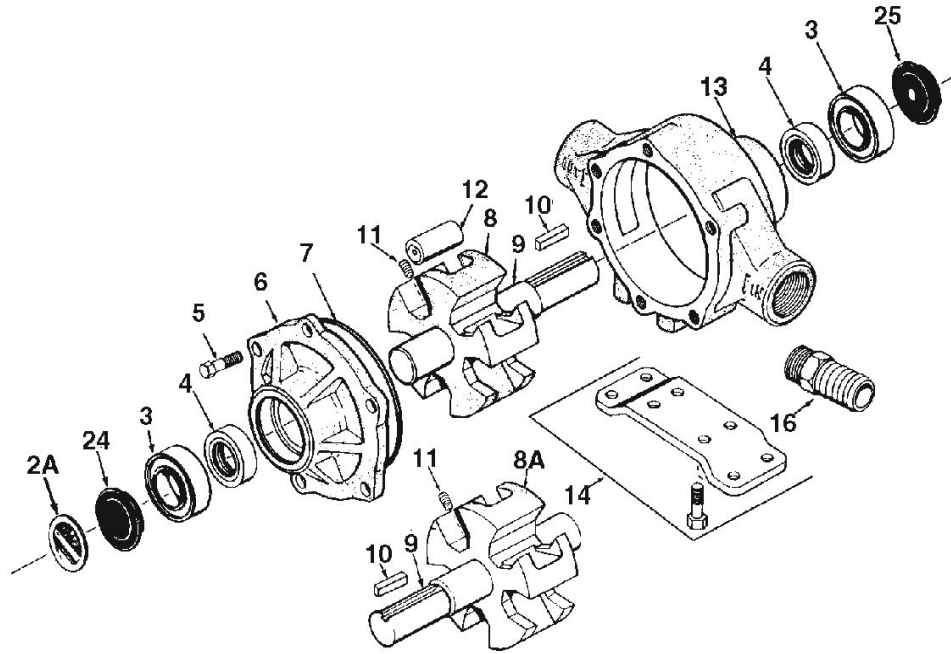

Ref. No.	Qty. Req'd.	Part Number	Description
2A	1	6031-0258	Name Plate (Specify Pump Model #)
3	2	2008-0001	Sealed Ball Bearing
4	2	2112-0003	Viton Seal (Standard)
4	2	2112-0001	Buna-N Seal (Optional)
5	6	2210-0005	Bolt
6	1	0200-1700C	Endplate (Cast Iron) with seal
6	1	0200-1700N	Endplate (Ni-Resist) with seal
6	1	0200-1700X	Endplate (SilverCast) with seal
7	1	1720-0099	O-ring Gasket for Endplate
8	1	0300-1700C	Rotor (Cast Iron) with shaft (Std. Rotation)
8	1	0300-1700N	Rotor (Ni-Resist) with shaft (Std. Rotation)
8	1	0300-1700X	Rotor (SilverCast) with shaft (Std. Rotation)
8A	1	0301-1700C	Rotor (Cast Iron) w/shaft (Reverse Rotation)
8A	1	0301-1700N	Rotor (Ni-Resist) w/shaft (Reverse Rotation)
8A	1	0301-1700X	Rotor (SilverCast) w/shaft (Reverse Rot.)

Ref. No.	Qty. Req'd.	Part Number	Description
9	1	0500-1502	Shaft Only
10	1	1610-0005	Key
11	1	2230-0018	Set Screw
11	1	2230-0034	Set Screw (SilverCast Only)
12	5	1005-0005	Super Roller (Standard)
12	5	1002-0005	Polypropylene Roller (Optional)
12	5	1055-0005	Teflon Roller (Optional)
13	1	0100-1700C	Body (Cast Iron) with seal
13	1	0100-1700N	Body (Ni-Resist) with seal
13	1	0100-1700X	Body (SilverCast) with seal
14	1 kit	3420-0010	Base Kit — Includes: (1) Base and (4) Bolts
16	1	2404-0191	1-1/4" Hose Barb
24	1	2300-0020	Bearing Cover
25	1	2300-0022	Shaft Bearing Cover

Repair Parts Kit No. 3430-0437 Consists of: (5) Ref. 12 Super Rollers, (1) Ref. 7 O-Ring Gasket, and (2) Ref. 4 Viton Seals.

Repair Parts Kit No. 3430-0383 (Universal) Consists of: (6) Ref. 12 Super Rollers, (2) Ref. 7 O-Ring Gaskets, and (2) Ref. 4 Viton Seals.

Repair Parts Kit No. 3430-0160 Consists of: (5) Ref. 12 Polypropylene Rollers and (1) Ref. 7 O-Ring Gasket, and (2) Ref. 4 Buna-N Seals.

Repair Parts Kit No. 3430-0159 Consists of: (5) Ref. 12 Polypropylene Rollers and (1) Ref. 7 O-Ring Gasket.

Repair Parts Kit No. 3430-0161 Consists of: (5) Ref. 12 Polypropylene Rollers and (1) Ref. 7 O-Ring Gasket, and (2) Ref. 4 Viton Seals.

Repair Parts Kit No. 3430-0407 Consists of: (5) Ref. 12 Super Rollers, (1) Ref. 7 O-Ring Gasket, (2) Ref. 4 Viton Seals and (2) Ref. 3 Sealed Ball Bearings.

The Spray Tech part number can be derived by adding the prefix 'HY' to the listed Hypro numbers.

Models 1500C, 1500N, and 1500XL

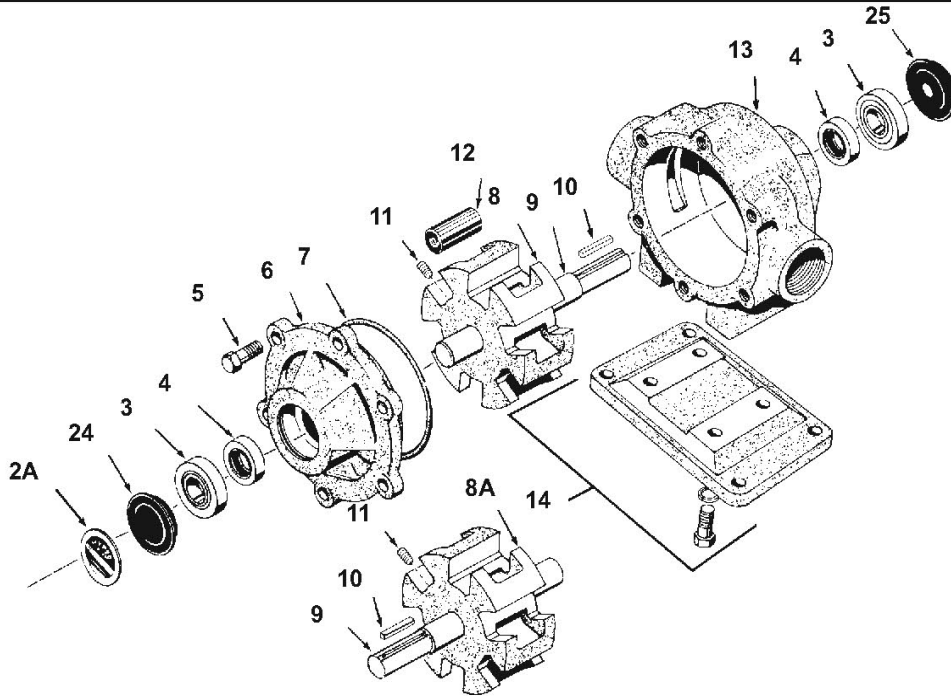

Ref. No.	Qty. Req'd.	Part Number	Description
2A	1	6031-0258	Name Plate (Specify Pump Model #)
3	2	2008-0001	Sealed Ball Bearing
4	2	2112-0001	Buna-N Seal (Standard)
4	2	2112-0003	Viton Seal (Optional) (Std. for SilverCast)
5	6	2210-0026	Bolt
6	1	0200-1500C	Endplate (Cast Iron) with seal
6	1	0200-1500N	Endplate (Ni-Resist) with seal
6	1	0200-1500X	Endplate (SilverCast) with seal
7	1	1720-0003	O-ring Gasket for Endplate
8	1	0300-1502C	Rotor (Cast Iron) with shaft (Std. Rotation)
8	1	0300-1502N	Rotor (Ni-Resist) with shaft (Std. Rotation)
8	1	0300-1502X	Rotor (SilverCast) with shaft (Std. Rotation)
8A	1	0301-1502C	Rotor (Cast Iron) w/shaft (Reverse Rotation)
8A	1	0301-1502N	Rotor (Ni-Resist) w/shaft (Reverse Rotation)
8A	1	0301-1502X	Rotor (SilverCast) w/shaft (Reverse Rotat.)
9	1	0500-1502	Shaft Only

Ref. No.	Qty. Req'd.	Part Number	Description
10	1	1610-0005	Key
11	1	2230-0018	Set Screw
11	1	2230-0034	Set Screw (SilverCast Only)
12	6	1005-0005	Super Roller (Standard)
12	6	1002-0005	Polypropylene Roller (Optional)
12	6	1055-0005	Teflon Roller (Optional)
13	1	0100-1500C	Body (Cast Iron) with seal
13	1	0100-1500N	Body (Ni-Resist) with seal
13	1	0100-1500X	Body (SilverCast) with seal
14	1 kit	3420-0004	Base Kit — Includes: (1) Base, (4) Bolts, (4) Lockwashers
24	1	2300-0020	Bearing Cover
25	1	2300-0022	Shaft Bearing Cover

Repair Parts Kit No. 3430-0383 (Universal) Consists of: (6) Ref. 12 Super Rollers, (2) Ref. 7 O-Ring Gaskets, and (2) Ref. 4 Viton Seals.

Repair Parts Kit No. 3430-0388 Consists of: (6) Ref. 12 Super Rollers and (1) Ref. 7 O-Ring Gasket.

Repair Parts Kit No. 3430-0386 Consists of: (6) Ref. 12 Super Rollers, (1) Ref. 7 O-Ring Gasket, and (2) Ref. 4 Viton Seals.

Repair Parts Kit No. 3430-0387 Consists of: (6) Ref. 12 Super Rollers, (1) Ref. 7 O-Ring Gasket, and (2) Ref. 4 Buna-N Seals.

Repair Parts Kit No. 3430-0162 Consists of: (6) Ref. 12 Polypropylene Rollers and (1) Ref. 7 O-Ring Gasket.

Repair Parts Kit No. 3430-0204 Consists of: (6) Ref. 12 Teflon Rollers, (1) Ref. 7 O-Ring Gasket, and (2) Ref. 4 Buna-N Seals.

Repair Parts Kit No. 3430-0164 Consists of: (6) Ref. 8 Polypropylene Rollers, (1) Ref. 7 O-Ring Gasket, and (2) Ref. 4 Viton Seals.

Repair Parts Kit No. 3430-0163 Consists of: (6) Ref. 8 Polypropylene Rollers, (1) Ref. 7 O-Ring Gasket, and (2) Ref. 4 Buna-N Seals.

Repair Parts Kit No. 3430-0406 Consists of: (6) Ref. 12 Super Rollers, (1) Ref. 7 O-Ring Gasket, (2) Ref. 4 Viton Seals and (2) Ref. 3 Sealed Ball Bearings.

The Spray Tech part number can be derived by adding the prefix 'HY' to the listed Hypro numbers.

Models 9006C-O, 9006C-O-SP, 9016C-O, 9016C-O-SP, 9008C-O, 9018C-O, 9028C-O

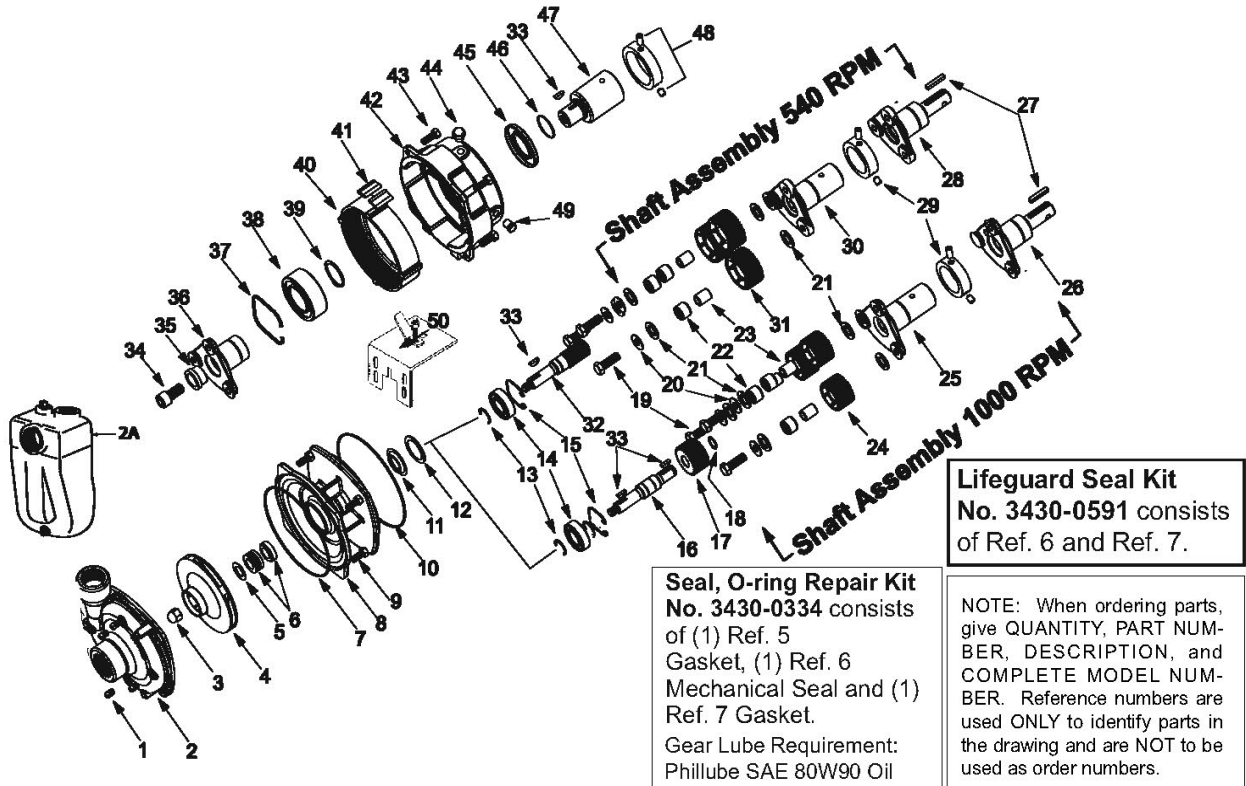

Ref. No.	Qty. Req'd.	Part No.	Description
1	4	2406-0007	Drain Plug
2	1	0150-9000C	Pump Casing (w / SS wear ring)
2A	1	3430-0480SP	Pump Casing (Self-Priming Units)
3	1	2253-0001	Impeller Nut
4	1	0400-9000P	Impeller (Nylon)
5	1	1700-0101	Gasket
6	1	2120-0010	Mechanical Seal (Optional Buna-N)
6	1	2120-0011	Mechanical Seal (Standard Viton)
7	1	1720-0083	O-ring
8	1	0752-9000C	Mounting Flange Adapter
9	4	2210-0020	Hex Head Capscrew
10	1	1720-0139	O-ring
11	1	2130-0018	Bearing Lip Seal
12	1	1700-0098	Gasket
13	*	1810-0013	Retaining Ring — (1) required for 540 rpm, (2) for 1-3/8" and (3) for 1-3/4" 1000 rpm
14	1	2008-0001	Ball Bearing
15	1	1820-0025	Retaining Ring
15	3	2210-0046	Capscrew
16	1	0500-9002	Impeller Shaft (1000 rpm)
17	1	3900-0013	Sun Gear (1000 rpm)
18	1	1810-0011	Retaining Ring (1000 rpm)
19	3	2210-0046	Hex Head Capscrew
20	3	2270-0003	Washer
21	6	2265-0003	Thrust Washer
22	3	2007-0052	Bearing (included with driver gear)
23	3	2007-0022	Bearing Inner Race
24	3	3900-0040	Driver Gear w/Bearing (1000 rpm) 32 teeth, Dia. 2.13"

Ref. No.	Qty. Req'd.	Part No.	Description
25	1	0562-9002D	Driver Hub (Model 9008C-O)
26	1	0501-9018D	Driver Hub (Model 9018C-O)
27	1	1610-0005	Key
28	1	0501-9016D	Driver Hub (Model 9016C-O)
29	1	3435-0058	Locking Collar Kit (hollow shaft)
30	1	0562-9000D	Driver Hub (Model 9006C-O)
31	3	3900-0039	Driver Gear w/Bearing (540 rpm) 39 teeth, Dia. 2.6"
32	1	3900-0010	Impeller Shaft/Pinion Gear (540 rpm)
33	**	1610-0012	Woodruff Key ** (1) req'd for 540 rpm, (2) req'd for 1000 rpm models.
34	1	2220-0035	Capscrew (Model 9028C)
35	1	2403-0012	Bushing (Model 9028C)
36	1	0501-9018D1	Driver Hub (Model 9028C)
37	1	1800-0014	Retaining Ring
38	1	2005-0002	Ball Bearing
39	1	1810-0001	Retaining Ring
40	1	3900-0009	Ring Gear
41	8	1450-0004	Cushion Bumper
42	1	0754-9000C	Gear Casing
43	4	2210-0026	Hex Head Capscrew
44	1	2404-0193	Breather Vent
45	1	2102-0025	Oil Seal
46	1	1720-0022	O-ring
47	1	0550-1322F4	Driver Hub (9028C) 1-3/4" Hub 20 Teeth
48	1	3430-0190	Locking Collar Kit (Model 9028C)
49	4	2406-0019	Oil Plug
50	1	1520-0034	Mounting Clip

Lifeguard Seal Kit No. 3430-0591 consists of Ref. 6 and Ref. 7.

Seal, O-ring Repair Kit No. 3430-0334 consists of (1) Ref. 5 Gasket, (1) Ref. 6 Mechanical Seal and (1) Ref. 7 Gasket.
Gear Lube Requirement: Phillube SAE 80W90 Oil

NOTE: When ordering parts, give QUANTITY, PART NUMBER, DESCRIPTION, and COMPLETE MODEL NUMBER. Reference numbers are used ONLY to identify parts in the drawing and are NOT to be used as order numbers.

The Spray Tech part number can be derived by adding the prefix 'HY' to the listed Hypro numbers.

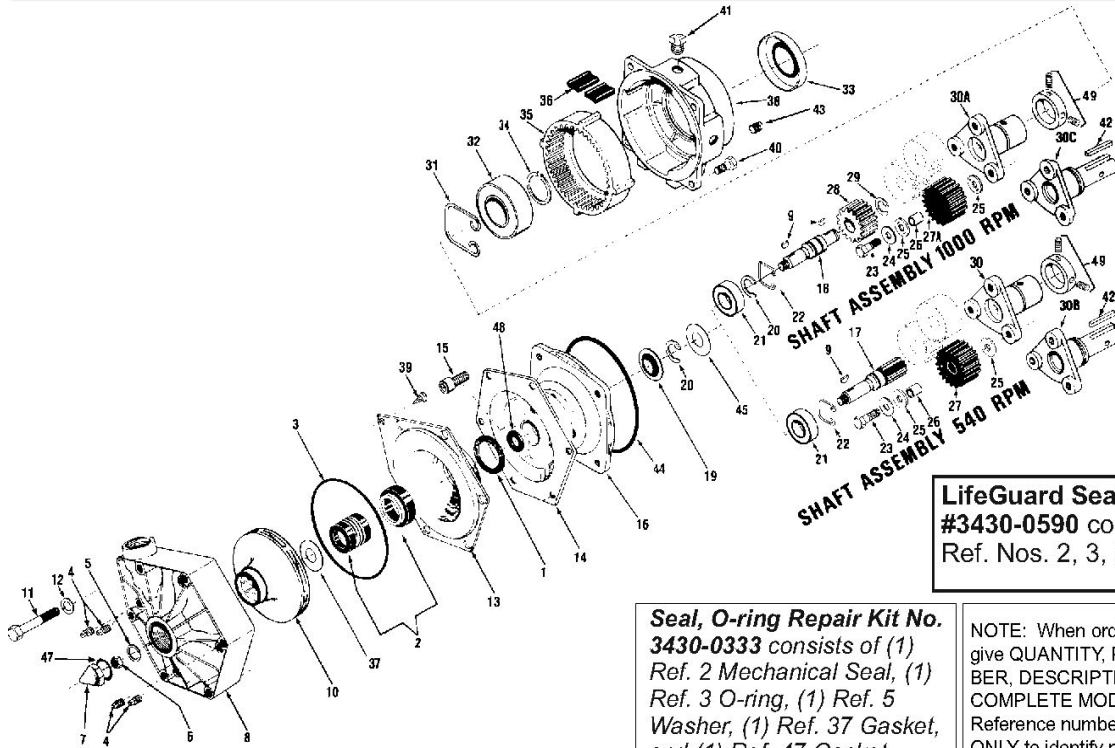

LifeGuard Seal Kit #3430-0590 consists of Ref. Nos. 2, 3, 5 and 47.

Seal, O-ring Repair Kit No. 3430-0333 consists of (1) Ref. 2 Mechanical Seal, (1) Ref. 3 O-ring, (1) Ref. 5 Washer, (1) Ref. 37 Gasket, and (1) Ref. 47 Gasket.

Gear Lube Requirement:
Phillube SAE 80W90 Oil

NOTE: When ordering parts, give QUANTITY, PART NUMBER, DESCRIPTION, and COMPLETE MODEL NUMBER. Reference numbers are used ONLY to identify parts in the drawing and are NOT to be used as order numbers.

Ref. No.	Qty. Req'd.	Part No.	Description
1	1	1410-0082	Spacer
2	1	2120-0011	Mechanical Seal
3	1	1721-0083	O-Ring
4	4	2406-0020	Plug
5	1	2270-0057	Washer
6	1	2250-0051	Jam Nut
7	1	2250-0052	Impeller Nut
8	1	0700-9000P	Pump Casing
9	**	1610-0042	Woodruff Key ** (1) required for Model 9006P, (2) for Model 9008P
10	1	0403-9000P	Impeller (Polypropylene)
11	6	2210-0087	Capscrew
12	6	2270-0041	Washer
13	1	0750-9000P	Back Cover
14	1	0750-9006C	Flange
15	4	2220-0013	Capscrew
16	1	0752-9006C	Flange
17	1	0503-9000	Shaft (Model 9006P)
18	1	0504-9000	Shaft (Model 9008P)
19	1	2130-0018	Bearing Lip Seal
20	*	1810-0013	Retaining Ring * (1) required for 9006P (2) for 9008P
21	1	2008-0001	Ball Bearing
22	1	1820-0025	Retaining Ring
23	3	2210-0046	Capscrew
24	3	2270-0003	Washer
25	6	2265-0003	Thrustwasher

Ref. No.	Qty. Req'd.	Part No.	Description
26	3	2007-0022	Bearing Inner Race
27	3	3900-0039	Driver Gear (Model 9006P) w/ bearing 540
27A	3	3900-0040	Driver Gear (Model 9008P) w/ bearing 1000
28	1	3900-0013	Sun Gear (Model 9008P)
29	1	1810-0011	Retaining Ring (Model 9008P)
30	1	0562-9000D	Driver Hub (9006P) 1-3/8" PTO 540 rpm
30A	1	0562-9002D	Driver Hub (9008P) 1-3/8" PTO 1000 rpm
30B	1	0501-9016D	Shaft (Solid) 540 rpm
30C	1	0501-9018D	Shaft (Solid) 1000 rpm
31	1	1800-0014	Retaining Ring
32	1	2005-0002	Ball Bearing
33	1	2102-0025	Oil Seal
34	1	1810-0001	Retaining Ring
35	1	3900-0009	Ring Gear
36	8	1450-0004	Cushion Bumper
37	1	1700-0101	Gasket
38	1	0754-9000C	Gear Casing
39	1	2210-0088	Hex Head Screw
40	4	2210-0026	Capscrew
41	1	2404-0193	Breather Vent
43	4	2406-0019	Oil Plug
44	1	1720-0139	O-Ring
45	1	1700-0098	Gasket
47	1	1700-0097	Gasket
48	1	1410-0083	Slinger Ring
	1		Nameplate (not shown)
49	1	3435-0058	Locking Collar Kit (hollow shaft only)

The Spray Tech part number can be derived by adding the prefix 'HY' to the listed Hypro numbers.

9202 Cast Iron and Stainless Steel Series

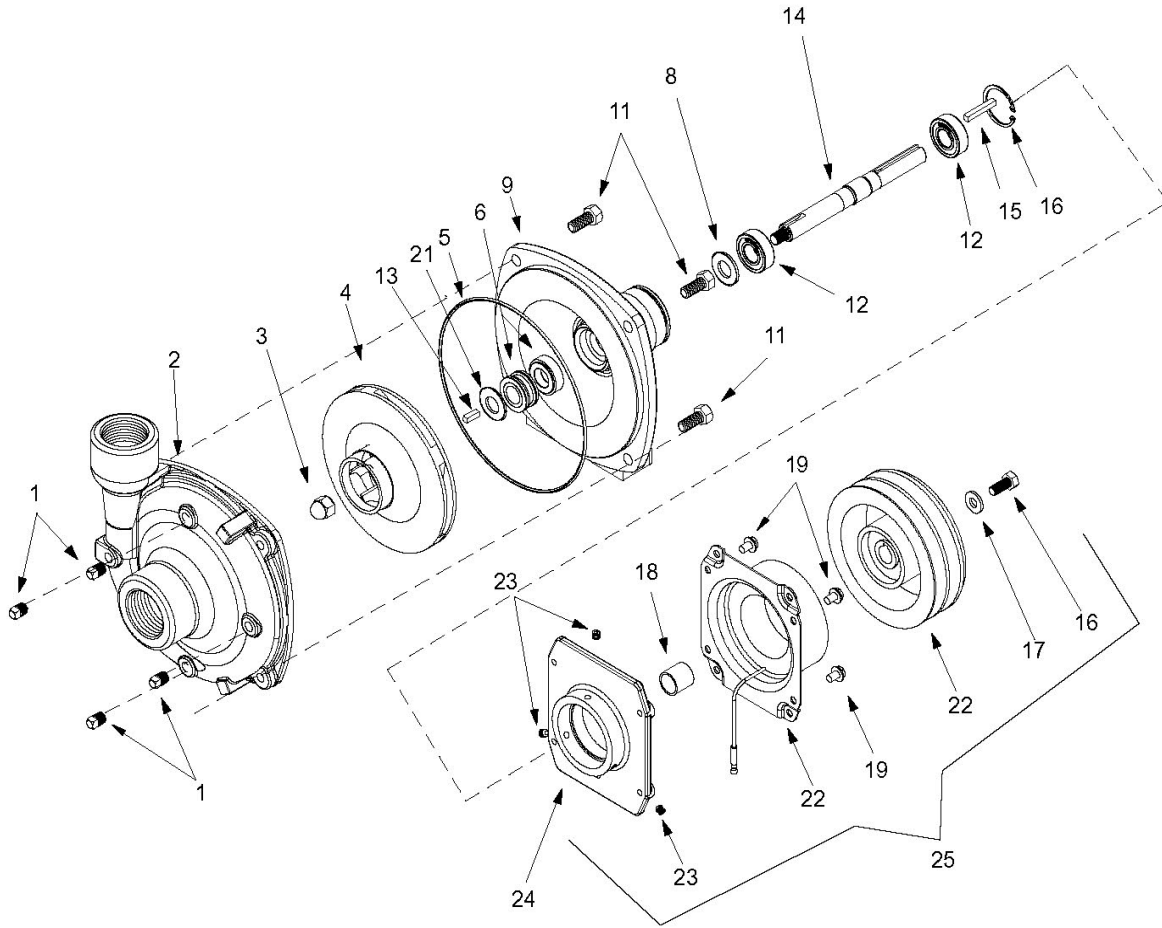

Seal Kit for 9202C, 9262C-C
No. 3430-0332 consists of:
(1) Ref. 5 O-Ring
(1) Ref. 6 Mechanical seal
(1) Ref. 21 Gasket

Seal Kit for 9202S,9262S-C
No. 3430-0589 consists of:
(1) Ref. 5 O-Ring
(1) Ref. 6 Mechanical seal

Ref. No.	Qty. Req'd	Part No.	Description
1	4	2406-0007	Drain Plug
1	4	2406-0016	Drain Plug (316 S.S. Model 9202S)
2	1	0150-9200C	Pump Casing (Model 9202C)
2	1	0150-9200S	Pump Casing (Model 9202S)
3	1	2253-0002	Impeller Nut
3	1	2253-0006	Impeller Nut (Model 9202S)
4	1	0401-9100P	Impeller (Model 9202C) (Nylon)
4	1	0402-9100P	Impeller (Model 9202S) (Poly)
5	1	1720-0083	O-Ring
6	1	2120-0008	Mechanical Seal (Optional Buna-N)
6	1	2120-0009	Mechanical Seal (Model 9202C)
6	1	3430-0589	Mech. Seal (Silicon Carbide) Model 9202S Includes ref #5 O-Ring
8	1	1410-0056	Slinger Ring
9	1	0750-9200C3	Mounting Flange (Model 9202C)
9	1	0756-9200S	Mounting Flange (Model 9202S)
11	4	2210-0020	Bolt (Model 9202C)

Ref. No.	Qty. Req'd	Part No.	Description
11	4	2210-0125	Bolt (Model 9202S)
12	2	2000-0010	Ball Bearing
13	1	1610-0015	Key (Model 9202C)
13	1	1610-0057	Key (Model 9202S)
14	1	0505-9200	Pump Shaft
15	1	1610-0004	Key
16	1	2210-0003	Bolt
17	1	2270-0092	Retaining Washer
18	1	1410-0107	Spacer
19	4	N/A	Bolt (part of Clutch Assy)
20	1	1820-0013	Bearing Retainer
21	1	1700-0100	Gasket (Model 9262C-C)
22	1	2526-0012	Clutch (Model 9262S-C)
23	3	2230-0001	Set Screw
24	1	0753-9200C	Mounting Bracket
25	1	3430-0592	Clutch Kit

The Spray Tech part number can be derived by adding the prefix 'HY' to the listed Hypro numbers.

9203 Cast Iron and Stainless Steel Series

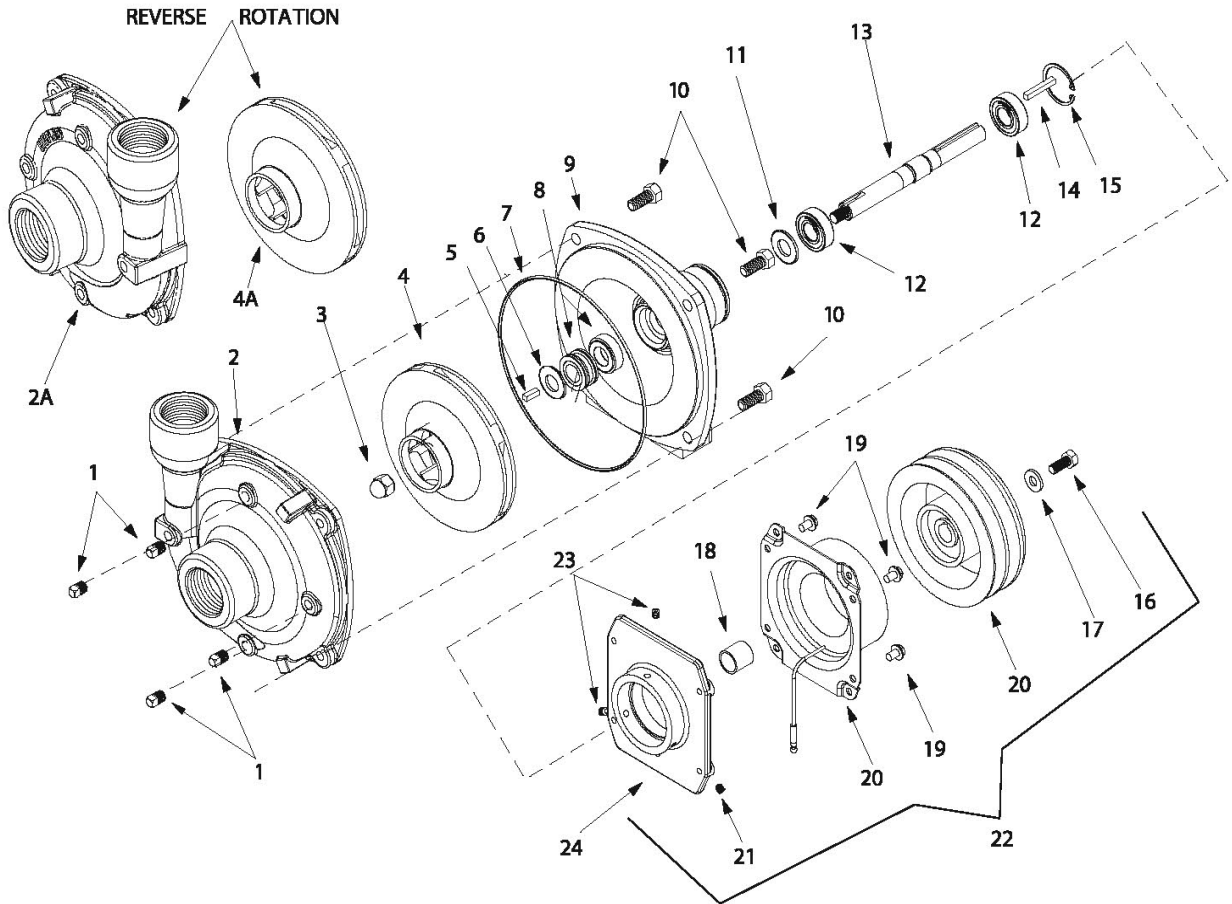

Seal Kit for Stainless Series:
No. 3430-0589 consists of:
(1) Ref. 7 O-Ring
(1) Ref. 8 Mechanical seal

Seal Kit for Cast Iron Series
No. 3430-0332 consists of:
(1) Ref. 7 O-Ring
(1) Ref. 8 Mech. seal
(1) Ref. 6 Gasket

No.	Qty. Req'd.	Part No.	Description
1	4	2406-0007	Drain Plug (Cast series)
1	4	2406-0016	Drain Plug (316 Stainless series)
2	1	0150-9000C	Pump Casing (Cast series)
2	1	0150-9000S	Pump Casing (Stainless series)
2A	1	0152-9000C	Pump Casing (Reverse)(Cast series)
2A	1	0152-9000S	Pump Casing (Reverse)(Stainless)
3	1	2253-0002	Impeller Nut (Cast series)
3	1	2253-0006	Impeller Nut (Stainless series)
4	1	0401-9100P	Impeller (Model 9203C) (Nylon)
4	1	0402-9100P	Impeller (Model 9203S) (Poly)
4A	1	0404-9100P	Impeller (Reverse)(Cast series)
4A	1	0403-9100P	Impeller (Reverse)(Stainless series)
5	1	1610-0015	Key (Cast series)
5	1	1610-0057	Key (Stainless series)
6	1	1700-0100	Gasket (Cast series)
7	1	1720-0083	O-Ring
8	1	2120-0008	Mechanical Seal (Optional Buna-N)
8	1	2120-0009	Mechanical Seal (Cast series)

Ref. No.	Qty. Req'd.	Part No.	Description
8	1	3430-0589	Mech. Seal (Silicon Carbide) (Stainless) Includes ref #5 O-Ring
9	1	0750-9200C3	Mounting Flange (Cast series)
9	1	0756-9200S	Mounting Flange (Stainless series)
10	4	2210-0020	Bolt (Cast series)
10	4	2210-0125	Bolt (Stainless series)
11	1	1410-0056	Slinger Ring
12	2	2000-0010	Ball Bearing
13	1	0505-9200	Pump Shaft
14	1	1610-0004	Key
15	1	1820-0013	Bearing Retainer
16	1	2210-0003	Bolt
17	1	2270-0092	Retaining Washer
18	1	1410-0107	Spacer
19	4	N/A	Bolt (part of clutch assy)
20	1	2526-0012	Clutch
21	3	2230-0001	Setscrew
22	1	3430-0592	Clutch Kit

The Spray Tech part number can be derived by adding the prefix 'HY' to the listed Hypro numbers.

Model 9205C

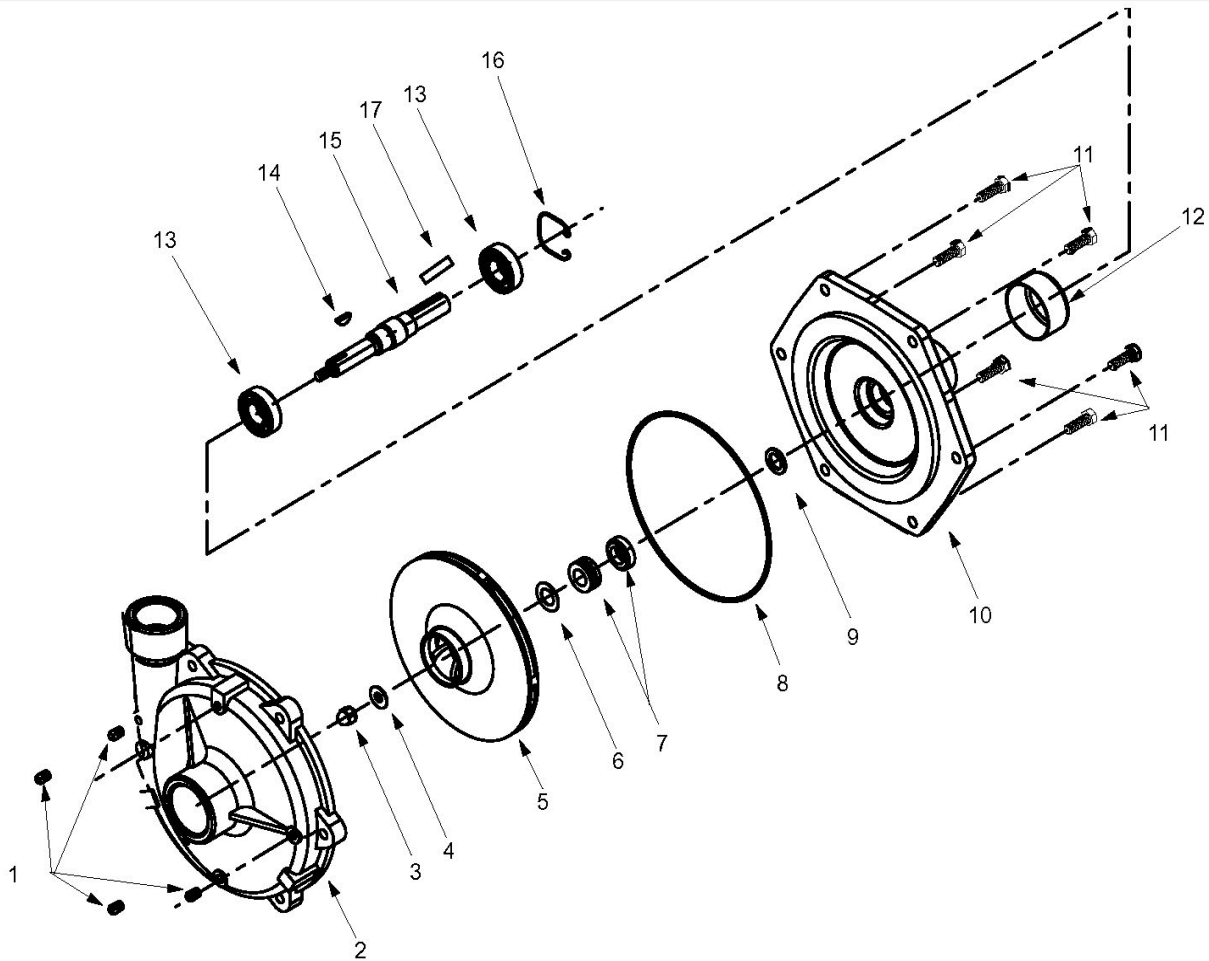

Seal Kit for 9205C
No. 3430-0537 consists of:
(1) Ref. 6 Gasket
(1) Ref. 7 Mechanical seal
(1) Ref. 8 O-Ring

Ref. No.	Qty. Req'd.	Part No.	Description
1	4	2406-0007	Drain Plug
2	1	0152-9200C	Pump Casing
3	1	2253-0002	Impeller Nut
4	1	2270-0071	Washer
5	1	0403-9200P	Impeller (Nylon)
6	1	1700-0101	Gasket
7	1	2120-0011	Mechanical Seal (Viton)
8	1	1720-0180	O-Ring

Ref. No.	Qty. Req'd.	Part No.	Description
9	1	1410-0083	Slinger Ring
10	1	0751-9200C	Mounting Flange
11	6	2210-0086	Bolt
12	1	2300-0035	Protective Cover
13	2	2008-0001	Ball Bearing
14	1	1610-0012	Key
15	1	0507-9200	Pump Shaft
16	1	1820-0025	Bearing Retainer
17	1	1610-0004	Key

The Spray Tech part number can be derived by adding the prefix 'HY' to the listed Hypro numbers.

Model 9206C and 9206S

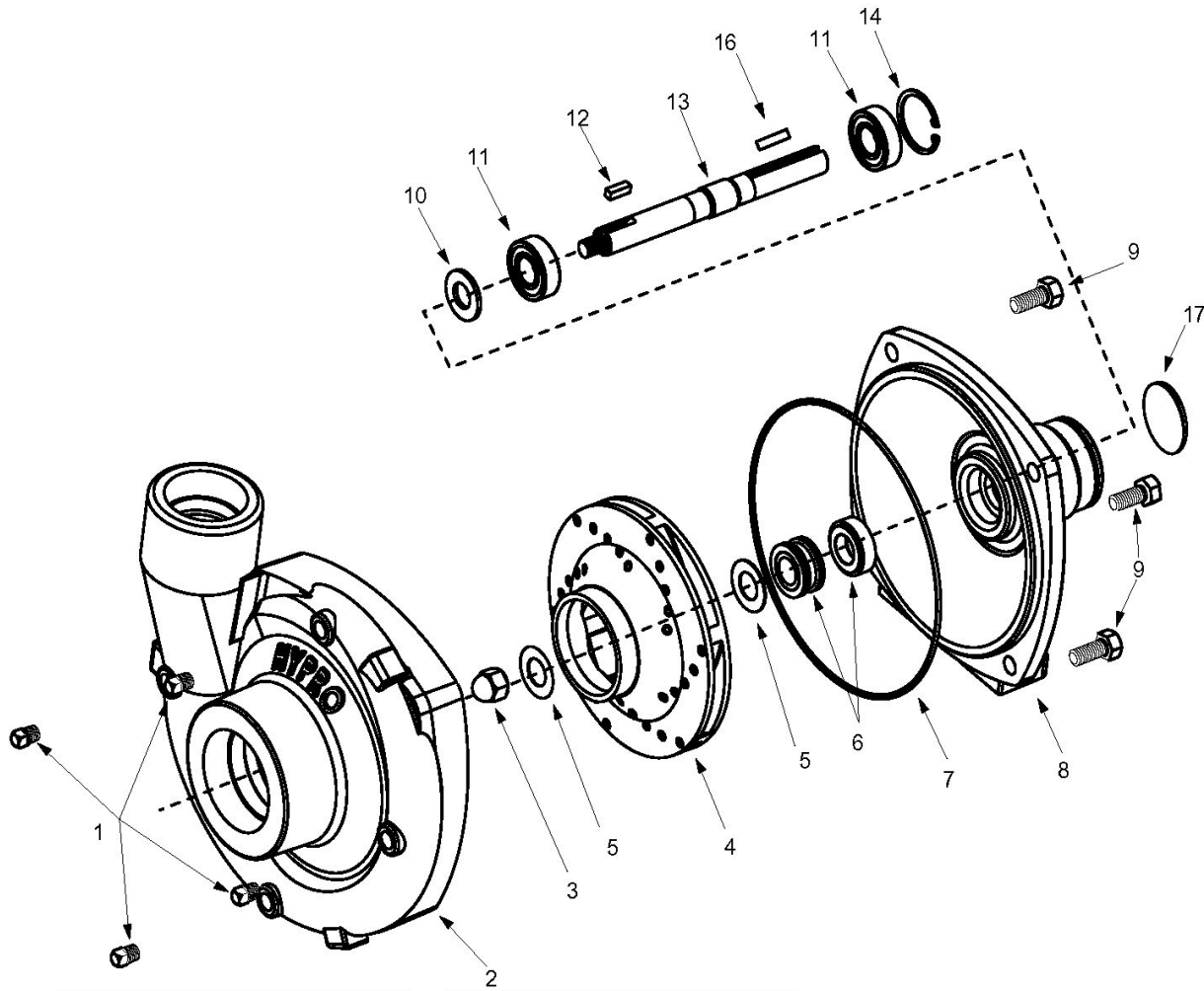

Seal Kit for 9206C
No. 3430-0332 consists of:
(1) Ref. 5 Gasket
(1) Ref. 6 Mechanical seal
(1) Ref. 7 O-Ring

Seal Kit for 9206S
No. 3430-0589 consists of:
(1) Ref. 6 Mechanical seal
(1) Ref. 7 O-Ring

Ref. No.	Qty. Req'd.	Part No.	Description
1	4	2406-0007	Pipe Plug 9206C
1	4	2406-0016	Pipe Plug 9206S
2	1	0154-9200C1	Cover 9206C
2	1	0154-9200S1	Cover 9206S
3	1	2253-0002	Impeller Nut 9206C
3	1	2253-0006	Impeller Nut 9206S
4	1	0401-9200P1	Nylon Impeller 9206C
4	1	0405-9200P	Poly Impeller 9206S
5	1	1700-0100	Gasket (Cast iron only)
6	1	2120-0009	Mech. Seal 9206C
6	1	3430-0589	Silicon Carbide Seal 9206S
7	1	1720-0083	O-Ring
8	1	0750-9200C4	Mounting Flange 9206C

Ref. No.	Qty. Req'd.	Part No.	Description
8	1	0756-9200S	Mounting Flange 9206S
9	4	2210-0020	Screw Hex Head 9206C
9	4	2210-0125	Screw Hex Head 9206S
10	1	1410-0056	Slinger Ring
11	2	2000-0010	Bearing
12	1	1610-0053	Key 9206C
12	1	1610-0057	Key 9206S
13	1	0505-9200	Shaft
14	1	1820-0013	Retaining Ring
15	1	2270-0071	Washer
16	1	1610-0004	Key
17	1	2300-0025	Protective Cover

The Spray Tech part number can be derived by adding the prefix 'HY' to the listed Hypro numbers.



All 9302C and 9302S Series Pumps

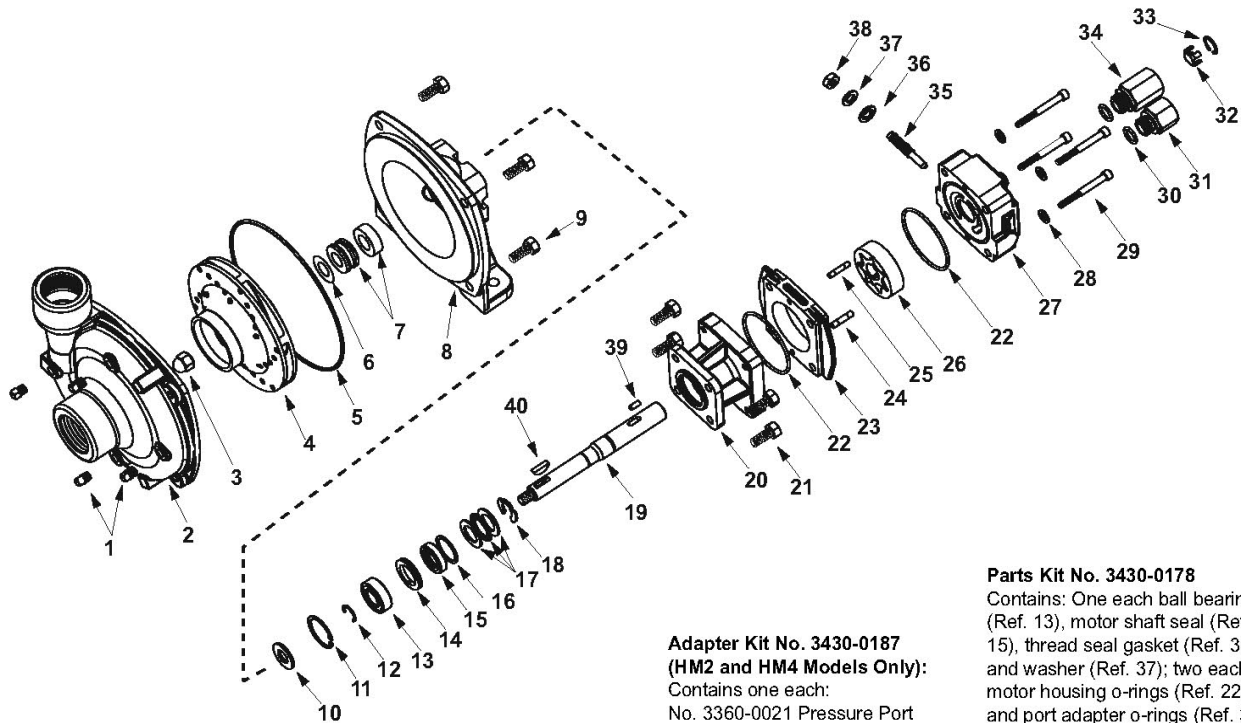

Repair Parts Kit No. 3430-0332

Contains: One o-ring (Ref. 5), one rubber gasket (Ref. 6), and one mechanical seal (Ref. 7).

Silicon Seal Kit No. 3430-0589

Contains one each: 1720-0083 o-ring (Ref. 5) and mechanical seal (silicon carbide) (Ref.7).

Adapter Kit No. 3430-0187 (HM2 and HM4 Models Only):

Contains one each:
 No. 3360-0021 Pressure Port Adapter
 No. 3373-0020 (Size #1)
 No. 3373-0021 (Size #2)
 No. 3373-0022 (Size #3).
 No. 1720-0108 Adapter O-ring and
 No. 1720-0105 Orifice O-ring (Qty 3)

Parts Kit No. 3430-0178

Contains: One each ball bearing (Ref. 13), motor shaft seal (Ref. 15), thread seal gasket (Ref. 36), and washer (Ref. 37); two each motor housing o-rings (Ref. 22), and port adapter o-rings (Ref. 30).

Hydraulic Motor Part Nos.

2500-0009C (HM1C Models)
 2500-0010C (HM2C Models)
 2500-0012C (HM4C Models)

Ref. No.	Qty. Req'd	Part No.	Description
1	4	2406-0007	Drain/Vent Plug (9302C)
1	4	2406-0016	Drain/Vent Plug (9302S)
2	1	0150-9200C	Pump Casing (9302C)
2	1	0156-9200S	Pump Casing (Model 9302S)
3	1	2253-0002	Impeller Nut (9302C)
3	1	2253-0006	Impeller Nut (Model 9302S)
4	1	0401-9100P	Impeller (Nyglass, std. 9302C)
4	1	0402-9100P	Impeller (Optional Polypropylene) (Std 9302S)
5	1	1720-0083	O-ring
6	1	1700-0100	Rubber Gasket (9302C)
7	1	2120-0009	Mechanical Seal (Viton) (Std 9302C)
7	1	3430-0589	Mechanical Seal (Silicon Carbide) (9302S)
8	1	0750-9300C	Mounting Flange (9302C)
8	1	0756-9300S	Mounting Flange (Model 9302S)
9	4	2210-0020	Hex Head Cap Screw (9302C)
9	4	2210-0125	Hex Head Cap Screw (Model 9302S)
10	1	1410-0056	Slinger Ring
11	1	1820-0013	Retaining Ring
12	1	1810-0014	Snap Ring
13	1	2000-0010	Ball Bearing
14	1	1410-0073	Spacer
15	1	2104-0005	Shaft Seal
16	1	1410-0074	Seal Spacer
17	1	2029-0014	Thrust Bearing Assembly—Consists of: (1) Thrust Bearing & (2) Thrust Brg. Races
18	1	1810-0026	Snap Ring
19	1	0509-2500	Shaft (HM2C & HM4C Models) 6 3/4" Long
19	1	0511-2501	Shaft (HM1C) 7" Long
20	1	0151-2500C	Motor Body (Includes Main Bearing)

Ref. No.	Qty. Req'd	Part No.	Description
21	4	2210-0005	Hex Head Cap Screw
22	2	1720-0110	O-ring
23	1	0701-2500C1	Gerotor Housing (HM2C Models) 1/4" Wide
23	1	0700-2500C1	Gerotor Housing (HM1C Models) 1/2" Wide
23	1	0703-2500C1	Gerotor Housing (HM4C Models) 5/16" Wide
24	1	1600-0045	Dowel Pin (HM2C & HM4C Models)
24	1	1600-0044	Dowel Pin (HM1C)
25	1	1600-0042	Dowel Pin (HM2C & HM4C Models)
25	1	1600-0037	Dowel Pin (HM1C)
26	1	3900-0022	Gerotor (HM1C Models)
26	1	3900-0023	Gerotor (HM2C Models)
26	1	3900-0025	Gerotor (HM4C Models)
27	1	0251-2500C2	Motor End Plate (Includes Main Bearing)
28	4	2270-0039	Washer
29	4	2220-0045	Cap Screw (HM2C & HM4C Models)
29	4	2220-0021	Cap Screw (HM1C)
30	2	1720-0108	O-ring
31	1	3360-0021	Pressure Port Adapter
32	1	3260-0068	Poppet
33	1	1820-0038	Retaining Ring
34	1	3320-0049	Tank Port Adapter
35	1	3220-0029	Bypass Adjusting Screw
36	1	1700-0047	Gasket
37	1	2270-0027	Washer
38	1	2250-0038	Lock Nut
39	1	1610-0032	Roll Pin (HM2C & HM4C Models)
39	1	1610-0031	Roll Pin (HM1C)
40	1	1610-0012	Woodruff Key(9302C)
40	1	04432	S.S. Woodruff Key (Model 9302S)

The Spray Tech part number can be derived by adding the prefix 'HY' to the listed Hypro numbers.

All 9303C and 9303S Series Pumps

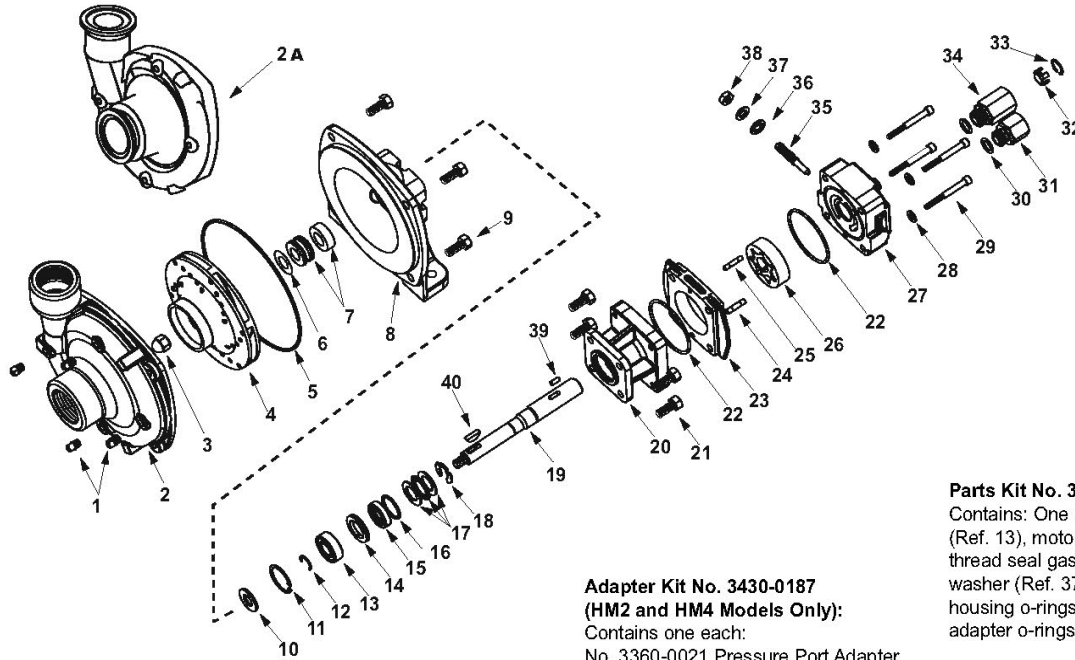

Repair Parts Kit No. 3430-0332

Contains: One o-ring (Ref. 5), one rubber gasket (Ref. 6), and one mechanical seal (Ref. 7).

Silicon Seal Kit No. 3430-0589

Contains one each: 1720-0083 o-ring (Ref. 5) and one mechanical seal (silicon carbide) (Ref. 7).

Adapter Kit No. 3430-0187

(HM2 and HM4 Models Only):
Contains one each:

- No. 3360-0021 Pressure Port Adapter
- No. 3373-0020 (Size #1)
- No. 3373-0021 (Size #2)
- No. 3373-0022 (Size #3).
- No. 1720-0108 Adapter O-ring and
- No. 1720-0105 Orifice O-ring (Qty 3).

Parts Kit No. 3430-0178

Contains: One each ball bearing (Ref. 13), motor shaft seal (Ref. 15), thread seal gasket (Ref. 36), and washer (Ref. 37); two each motor housing o-rings (Ref. 22), and port adapter o-rings (Ref. 30).

Hydraulic Motor Part Nos.

- 2500-0009C (HM1C Models)
- 2500-0010C (HM2C Models)
- 2500-0011C (HM3C Models)
- 2500-0012C (HM4C Models)
- 2500-0018C (HM5C Models)

Ref. No.	Qty. Req'd.	Part No.	Description
1	4	2406-0007	Drain/Vent Plug (9303C)
1	4	2406-0016	Drain/Vent Plug (9303S)
2	1	0150-9000C	Pump Casing (Model 9303C)
2	1	0150-9000S	Pump Casing (Model 9303S)
2A	1	0153-9000C	Pump Casing (Universal Flange)
3	1	2253-0002	Impeller Nut (9303C)
3	1	2253-0006	Impeller Nut (Model 9303S)
4	1	0401-9100P	Impeller (Nylglass, std.) (9303C)
4	1	0402-9100P	Impeller (Optional Polypropylene) (Std 9303S)
5	1	1720-0083	O-ring
6	1	1700-0100	Rubber Gasket (9303C)
7	1	2120-0009	Mechanical Seal (Viton) (Std 9303C)
7	1	3430-0589	Mechanical Seal (Silicon Carbide) (Std 9303S)
8	1	0750-9300C	Mounting Flange
8	1	0756-9300S	Mounting Flange (Model 9303S)
9	4	2210-0020	Hex Head Cap Screw (9303C)
9	4	2210-0125	Hex Head Cap Screw (Model 9303S)
10	1	1410-0056	Slinger Ring
11	1	1820-0013	Retaining Ring
12	1	1810-0014	Snap Ring
13	1	2000-0010	Ball Bearing
14	1	1410-0073	Spacer
15	1	2104-0005	Shaft Seal
16	1	1410-0074	Seal Spacer
17	1	2029-0014	Thrust Bearing Assembly—Consists of: (1) Thrust Bearing & (2) Thrust Brg. Races
18	1	1810-0026	Snap Ring
19	1	0509-2500	Shaft (HM2C & HM4C Models) 6-3/4" Long
19	1	0511-2501	Shaft (HM1C & HM5C Models) 7" Long
19	1	0510-2500	Shaft (HM3C Models) 7 -1/2" Long
20	1	0151-2500C	Motor Body (Includes Main Bearing)
21	4	2210-0005	Hex Head Cap Screw
22	2	1720-0110	O-ring
23	1	0701-2500C1	Gerotor Housing (HM2C Models) 1/4" Wide

Ref. No.	Qty. Req'd.	Part No.	Description
23	1	0700-2500C1	Gerotor Housing (HM1C Models) 1/2" Wide
23	1	0703-2500C1	Gerotor Housing (HM4C Models) 5/16" Wide
23	1	0702-2500C1	Gerotor Housing (HM3C Models) 1" Wide
23	1	0704-2500C1	Gerotor Housing (HM5C Models) 5/8" Wide
24	1	1600-0045	Dowel Pin (HM2C & HM4C Models)
24	1	1600-0044	Dowel Pin (HM1C & HM5C Models)
24	1	1600-0052	Dowel Pin (HM3C Models)
25	1	1600-0042	Dowel Pin (HM2C & HM4C Models)
25	1	1600-0037	Dowel Pin (HM1C & HM5C Models)
25	1	1600-0068	Dowel Pin (HM3C Models)
26	1	3900-0022	Gerotor (HM1C Models)
26	1	3900-0023	Gerotor (HM2C Models)
26	1	3900-0024	Gerotor (HM3C Models)
26	1	3900-0025	Gerotor (HM4C Models)
26	1	3900-0048	Gerotor (HM5C Models)
27	1	0251-2500C2	Motor End Plate (Includes Main Bearing)
28	4	2270-0039	Washer
29	4	2220-0045	Cap Screw (HM2C & HM4C Models)
29	4	2220-0021	Cap Screw (HM1C)
29	4	2220-0044	Cap Screw (HM3C Models)
29	4	2220-0032	Cap Screw (HM5C)
30	2	1720-0108	O-ring
31	1	3360-0021	Pressure Port Adapter
32	1	3260-0068	Poppet
33	1	1820-0038	Retaining Ring
34	1	3320-0049	Tank Port Adapter
35	1	3220-0029	Bypass Adjusting Screw
36	1	1700-0047	Gasket
37	1	2270-0027	Washer
38	1	2250-0038	Lock Nut
39	1	1610-0032	Roll Pin (HM2C & HM4C Models)
39	1	1610-0031	Roll Pin (HM1C & HM5C Models)
39	1	1610-0055	Roll Pin (HM3C)
40	1	1610-0012	Woodruff Key (9303C)
40	1	04432	S.S. Woodruff Key (Model 9303S)

The Spray Tech part number can be derived by adding the prefix 'HY' to the listed Hypro numbers.



All 9300 Polypropylene Series Pumps

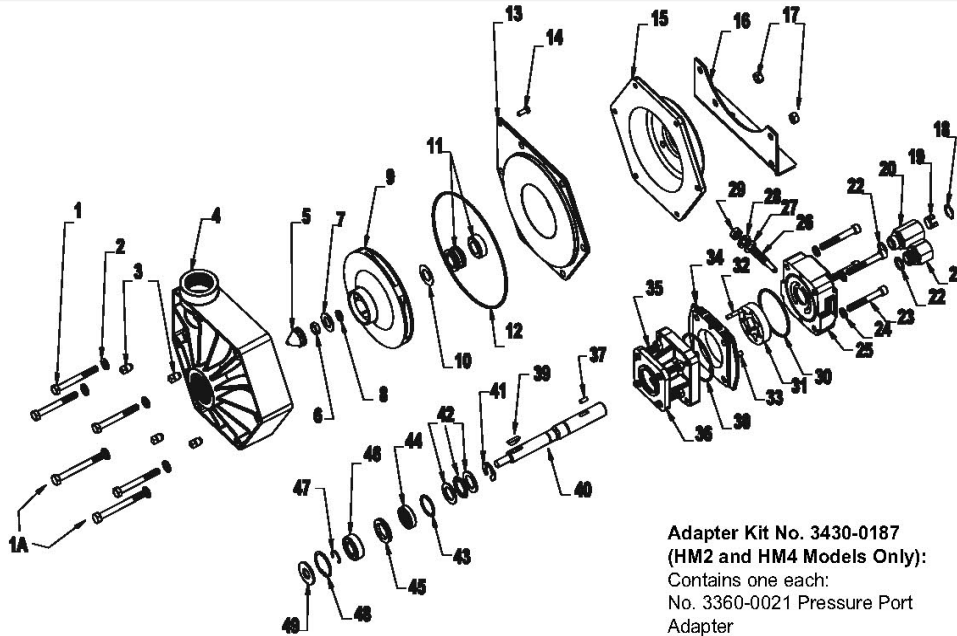

Repair Parts Kit No. 3430-0445

Contains: One o-ring (Ref. 12), one rubber gasket (Ref. 10), one mechanical seal (Ref. 11), one gasket (Ref. 7) and one washer (Ref. 8).

Silicon Seal Parts Kit # 3430-0593

Contains one each: mechanical seal (Ref. 11) and o-ring (Ref. 12).

Adapter Kit No. 3430-0187 (HM2 and HM4 Models Only):

Contains one each:
 No. 3360-0021 Pressure Port Adapter
 No. 3373-0020 (Size #1)
 No. 3373-0021 (Size #2)
 No. 3373-0022 (Size #3).
 No. 1720-0108 Adapter O-ring and
 No. 1720-0105 Orifice O-ring (Qty 3).

Parts Kit No. 3430-0178

Contains: One each ball bearing (Ref. 46), motor shaft seal (Ref. 44), thread seal gasket (Ref. 27), and washer (Ref. 28); two each motor housing o-rings (Ref. 30), and port adapter o-rings (Ref. 22).

Hydraulic Motor Part Nos.

2500-0019C (HM1C Models)
 2500-0022C (HM2C Models)
 2500-0013C (HM3C Models)
 2500-0014C (HM4C Models)
 2500-0021C (HM5C Models)

Ref. No.	Qty. Req'd.	Part No.	Description
1	4	2210-0087	Hex Head Cap Screw
1A	2	2210-0016	Hex Head Cap Screw (Base Only)
2	6	2270-0041	Washer
3	4	2406-0020	Pipe Plug
4	1	0700-9000P	Pump Casing
5	1	2250-0052	Impeller Nut
6	1	2250-0051	Jam Nut
7	1	1700-0097	Gasket (Viton)
8	1	2270-0057	Washer
9	1	0402-9100P	Impeller
10	1	1700-0100	Rubber Gasket
11	1	2120-0009	Mechanical Seal (Std)
11	1	3430-0593	Mechanical Seal (Silicon Carbide)(Optional)
12	1	1721-0083	O-Ring
13	1	0750-9300P	Cover
14	1	2210-0088	Screw
15	1	0750-9006C	Intermediate Flange
16	1	1510-0063	Base Plate
17	2	2250-0008	Hex Nut
18	1	1820-0038	Retaining Ring
19	1	3260-0068	Poppet
20	1	3320-0049	Check Valve Body
21	1	3360-0021	Pressure Port Adapter
22	2	1720-0108	O-ring
23	4	2220-0045	Socket Head Cap Screw (HM2, HM4C Model)
23	4	2220-0044	Socket Head Cap Screw (HM3C Model)
23	4	2220-0021	Socket Head Cap Screw (HM1C Model)
23	4	2220-0032	Socket Head Cap Screw (HM5C)
24	4	2270-0039	Washer
25	1	0251-2500C2	Motor End Plate: Includes (1) Main Bearing
26	1	3220-0029	Valve Stem
27	1	1700-0047	Gasket
28	1	2270-0027	Washer
29	1	2250-0038	Lock Nut
30	2	1720-0110	O-Ring
31	1	3900-0022	Gerotor (HM1C Models)

Ref. No.	Qty. Req'd.	Part No.	Description
31	1	3900-0023	Gerotor (HM2C Models)
31	1	3900-0024	Gerotor (HM3C Models)
31	1	3900-0025	Gerotor (HM4C Models)
31	1	3900-0048	Gerotor (HM5C Models)
32	1	1600-0042	Dowel Pin (HM2C & HM4C Models)
32	1	1600-0037	Dowel Pin (HM1C & HM5C Models)
32	1	1600-0068	Dowel Pin (HM3C Models)
33	1	1600-0045	Dowel Pin (HM2C & HM4C Models)
33	1	1600-0044	Dowel Pin (HM1C & HM5C Models)
33	1	1600-0052	Dowel Pin (HM3C Models)
34	1	0701-2500C1	Gerotor Housing (HM2C Models) 1/4" Wide
34	1	0700-2500C1	Gerotor Housing (HM1C Models) 1/2" Wide
34	1	0703-2500C1	Gerotor Housing (HM4C Models) 5/16" Wide
34	1	0702-2500C1	Gerotor Housing (HM3C Models) 1" Wide
34	1	0704-2500C1	Gerotor Housing (HM5C Models) 5/8" Wide
35	4	2210-0021	Hex Head Cap Screw
36	1	0151-2500C	Motor Body: Includes (1) Main Bearing
37	1	1610-0032	Roll Pin (HM2C & HM4C Models)
37	1	1610-0031	Roll Pin (HM1C & HM5C Models)
37	1	1610-0055	Roll Pin (HM3C)
39	1	1610-0012	Woodruff Key
40	1	0507-2500	Shaft (HM2C & HM4C Models) 7-1/16" Long
40	1	0506-2501	Shaft (HM1C & HM5C Models) 7-21/64" Long
40	1	0514-2500	Shaft (HM3C Models) 7-13/16" Long
41	1	1810-0026	Snap Ring
42	1	2029-0014	Thrust Bearing Assembly - Consists of: (1) Thrust Bearing & (2) Thrust Bearing Races
43	1	1410-0074	Seal Spacer
44	1	2104-0005	Shaft Seal
45	1	1410-0073	Spacer
46	1	2000-0010	Ball Bearing
47	1	1810-0014	Snap Ring
48	1	1820-0013	Retaining Ring
49	1	1410-0056	Slinger Ring

The Spray Tech part number can be derived by adding the prefix 'HY' to the listed Hypro numbers.

All 9304C Series Pumps (Discontinued)

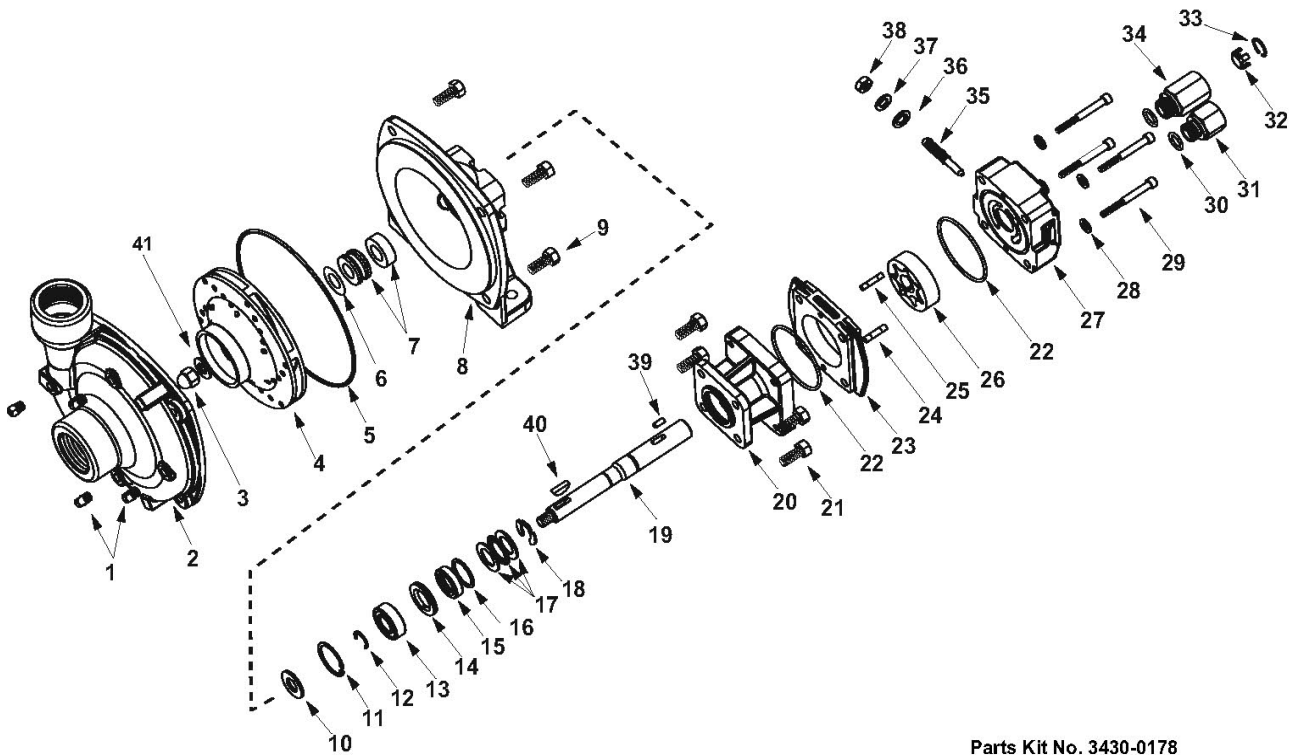

Repair Parts Kit No. 3430-0332
Contains: One o-ring (Ref. 5), one rubber gasket (Ref. 6), and one mechanical seal (Ref. 7).

Silicon Seal Kit No. 3430-0589
Contains one each: 1720-0083 o-ring (Ref. 5) and mechanical seal (silicon carbide) (Ref.7).

Hydraulic Motor Part Nos.
2500-0009C (HM1C Models)
2500-0011C (HM3C Models)
2500-0018C (HM5C Models)

Parts Kit No. 3430-0178

Contains: One each ball bearing (Ref. 13), motor shaft seal (Ref. 15), thread seal gasket (Ref. 36), and washer (Ref. 37); two each motor housing o-rings (Ref. 22), and port adapter o-rings (Ref. 30).

Ref. No.	Qty. Req'd.	Part No.	Description
1	4	2406-0007	Drain/Vent Plug
2	1	0151-9200C	Pump Casing
3	1	2253-0002	Impeller Nut
4	1	0401-9200P2	Impeller (Nyglass, std.)
4	1	0405-9200P2	Impeller (Optional Polypropylene)
5	1	1720-0083	O-ring
6	1	1700-0100	Rubber Gasket
7	1	2120-0009	Mechanical Seal (Viton) (Std)
7	1	3430-0589	Mechanical Seal (Silicon Carbide) (Optional)
8	1	0750-9300C	Mounting Flange
9	4	2210-0020	Hex Head Cap Screw
10	1	1410-0056	Slinger Ring
11	1	1820-0013	Retaining Ring
12	1	1810-0014	Snap Ring
13	1	2000-0010	Ball Bearing
14	1	1410-0073	Spacer
15	1	2104-0005	Shaft Seal
16	1	1410-0074	Seal Spacer
17	1	2029-0014	Thrust Bearing Assembly—Consists of: (1) Thrust Bearing & (2) Thrust Brg. Races
18	1	1810-0026	Snap Ring
19	1	0511-2501	Shaft (HM1C & HM5C Models) 7" Long
19	1	0510-2500	Shaft (HM3C Models) 7-1/2" Long
20	1	0151-2500C	Motor Body (Includes Main Bearing)
21	4	2210-0005	Hex Head Cap Screw
22	2	1720-0110	O-ring
23	1	0700-2500C1	Gerotor Housing (HM1C Models) 1/2" Wide

Ref. No.	Qty. Req'd.	Part No.	Description
23	1	0702-2500C1	Gerotor Housing (HM3C Models) 1" Wide
23	1	0704-2500C1	Gerotor Housing (HM5C Models) 5/8" Wide
24	1	1600-0044	Dowel Pin (HM1C & HM5C Models)
24	1	1600-0052	Dowel Pin (HM3C Models)
25	1	1600-0037	Dowel Pin (HM1C & HM5C Models)
25	1	1600-0068	Dowel Pin (HM3C Models)
26	1	3900-0022	Gerotor (HM1C Models)
26	1	3900-0024	Gerotor (HM3C Models)
26	1	3900-0048	Gerotor (HM5C Models)
27	1	0251-2500C2	Motor End Plate (Includes Main Bearing)
28	4	2270-0039	Washer
29	4	2220-0021	Cap Screw (HM1C Model)
29	4	2220-0032	Cap Screw (HM5C Model)
29	4	2220-0044	Cap Screw (HM3C Model)
30	2	1720-0108	O-ring
31	1	3360-0021	Pressure Port Adapter
32	1	3260-0068	Poppet
33	1	1820-0038	Retaining Ring
34	1	3320-0049	Tank Port Adapter
35	1	3220-0029	Bypass Adjusting Screw
36	1	1700-0047	Gasket
37	1	2270-0027	Washer
38	1	2250-0038	Lock Nut
39	1	1610-0031	Roll Pin (HM1C & HM5C Models)
39	1	1610-0055	Roll Pin (HM3C)
40	1	1610-0012	Woodruff Key
41	1	2270-0071	Washer

The Spray Tech part number can be derived by adding the prefix 'HY' to the listed Hypro numbers.

Models 9305C-HM3C

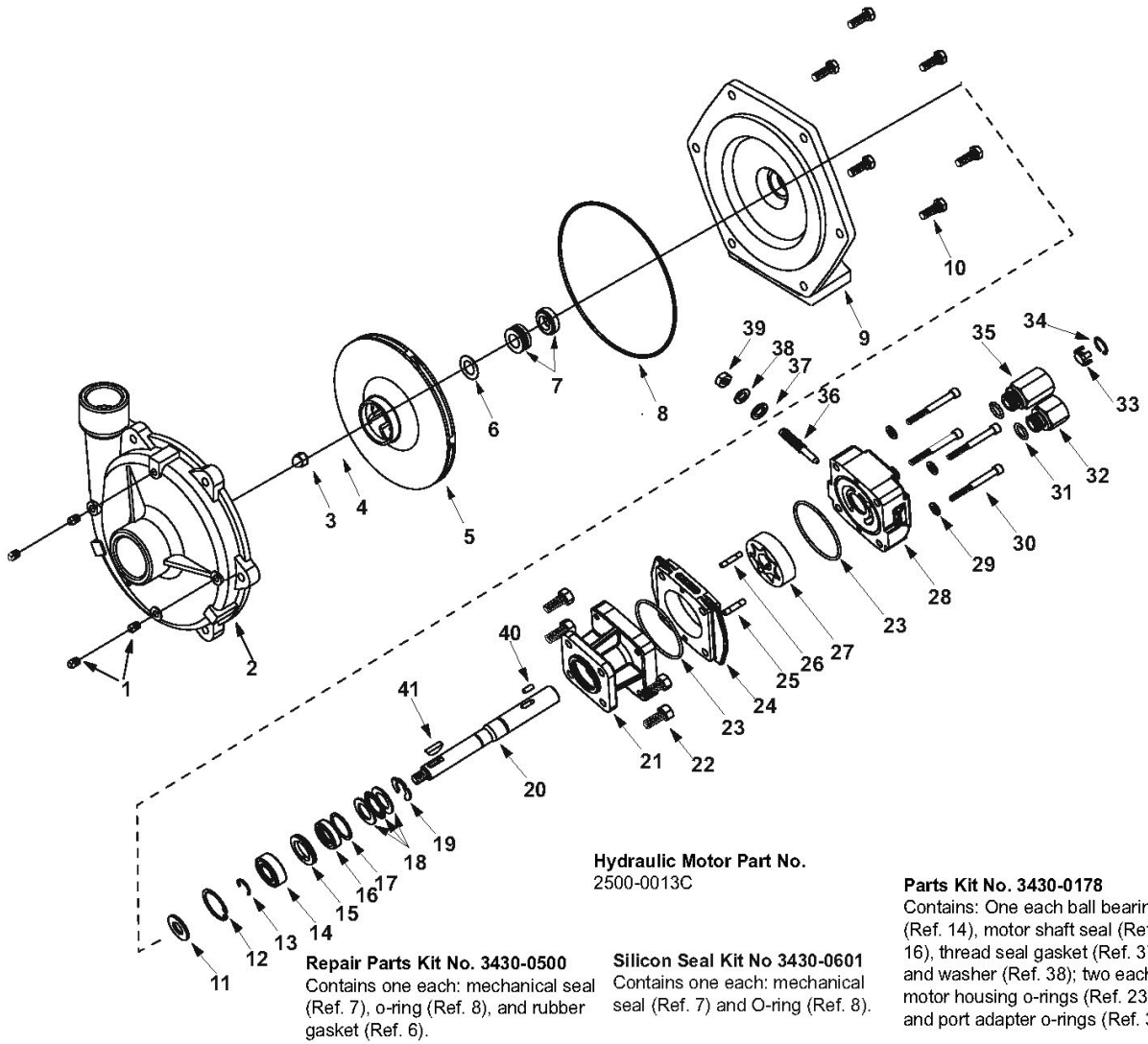

Ref. No.	Qty. Req'd.	Part No.	Description
1	1	2406-0007	Drain/Vent Plug
2	1	0152-9200CM	Pump Casing
3	1	2253-0002	Impeller Nut
4	1	2270-0071	Washer
5	1	0403-9200P1	Impeller
6	1	1700-0100	Rubber Gasket
7	1	2120-0009	Mechanical Seal (standard Viton)
7	1	3430-0601	Mechanical Seal (Silicon Carbide)(Optional)
8	1	1720-0180	O-ring
9	1	0752-9200C	Mounting Flange
10	6	2210-0086	Hex Head Cap Screw
11	1	1410-0056	Slinger Ring
12	1	1820-0013	Retaining Ring
13	1	1810-0014	Snap Ring
14	1	2000-0010	Ball Bearing
15	1	1410-0073	Spacer
16	1	2104-0005	Shaft Seal
17	1	1410-0074	Seal Spacer
18	1	2029-0014	Thrust Bearing Assembly - Consists of: (1) Thrust Bearing & (2) Thrust Brg. Races
19	1	1810-0026	Snap Ring
20	1	0514-2500	Shaft

Ref. No.	Qty. Req'd.	Part No.	Description
21	1	0151-2500C	Motor Body (Includes Main Bearing)
22	4	2210-0005	Hex Head Cap Screw
23	2	1720-0110	O-ring
24	1	0702-2500C1	Gerotor Housing 1" wide
25	1	1600-0052	Dowel Pin
26	1	1600-0068	Dowel Pin
27	1	3900-0024	Gerotor
28	1	0251-2500C2	Motor End Plate (Includes Main Bearing)
29	1	2270-0027	Washer
30	4	2220-0044	Cap Screw
31	2	1720-0108	O-ring
32	1	3360-0021	Pressure Port Adapter
33	1	3260-0068	Poppet
34	1	1820-0038	Retaining Ring
35	1	3320-0049	Tank Port Adapter
36	1	3220-0029	Bypass Adjusting Screw
37	1	1700-0047	Gasket
38	4	2270-0039	Washer
39	1	2250-0038	Lock Nut
40	1	1610-0055	Roll Pin
41	1	1610-0053	Key

The Spray Tech part number can be derived by adding the prefix 'HY' to the listed Hypro numbers.

All 9306C Series

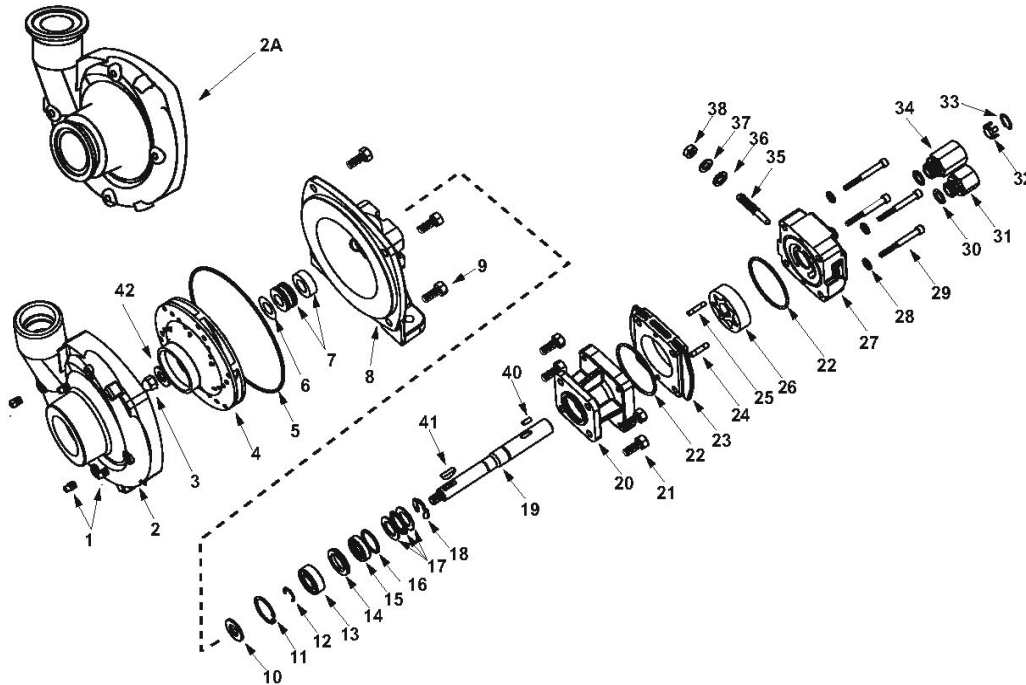

Repair Parts Kit No. 3430-0332
Contains: One mechanical seal (Ref. 7), one o-ring (Ref. 5) and one rubber gasket (Ref. 6).

Silicon Carbide Seal Kit No. 3430-0589
Contains one each: mechanical seal (Ref. 7) and o-ring (Ref. 5).

Hydraulic Motor Part Nos.
2500-0009C (HM1C Models)
2500-0011C (HM3C Models)
2500-0018C (HM5C Models)

Parts Kit No. 3430-0178
Contains: One each ball bearing (Ref. 13), motor shaft seal (Ref. 15), thread seal gasket (Ref. 36), and washer (Ref. 37); two each motor housing o-rings (Ref. 22), and port adapter o-rings (Ref. 30).

Ref. No.	Qty. Req'd.	Part No.	Description
1	4	2406-0007	Drain/Vent Plug
2	1	0154-9200C1	Pump Casing (Volute) (Includes a stainless steel wear ring)
2A	1	0157-9200C	Pump Casing (Universal Flange)
3	1	2253-0002	Impeller Nut
4	1	0401-9200P2	Impeller
5	1	1720-0083	O-ring
6	1	1700-0100	Rubber Gasket
7	1	2120-0009	Mechanical Seal (Viton)
7	1	3430-0589	Mechanical Seal (Silicon Carbide) (Optional)
8	1	0750-9300C	Mounting Flange
9	4	2210-0020	Hex Head Cap Screw
10	1	1410-0056	Slinger Ring
11	1	1820-0013	Retaining Ring
12	1	1810-0014	Snap Ring
13	1	2000-0010	Ball Bearing
14	1	1410-0073	Spacer
15	1	2104-0005	Shaft Seal
16	1	1410-0074	Seal Spacer
17	1	2029-0014	Thrust Bearing Assembly - Consists of: (1) Thrust Bearing & (2) Thrust Brg. Races
18	1	1810-0026	Snap Ring
19	1	0510-2500	Shaft (HM3C Model) 7-1/2" long
19	1	0511-2501	Shaft (HM1C & HM5C Models) 7" long
20	1	0151-2500C	Motor Body (Includes Main Bearing)
21	4	2210-0005	Hex Head Cap Screw
22	2	1720-0110	O-ring
23	1	0700-2500C1	Gerotor Housing (HM1C Model) 1/2" wide

Ref. No.	Qty. Req'd.	Part No.	Description
23	1	0702-2500C1	Gerotor Housing (HM3C Model) 1" wide
23	1	0704-2500C1	Gerotor Housing (HM5C Model) 5/8" wide
24	1	1600-0052	Dowel Pin (HM3C Models)
24	1	1600-0044	Dowel Pin (HM1C and HM5C Models)
25	1	1600-0068	Dowel Pin (HM3C Model)
25	1	1600-0037	Dowel Pin (HM1C and HM5C Models)
26	1	3900-0022	Gerotor (HM1C Model)
26	1	3900-0024	Gerotor (HM3C Model)
26	1	3900-0048	Gerotor (HM5C Model)
27	1	0251-2500C2	Motor End Plate (Includes Main Bearing)
28	4	2270-0039	Washer
29	4	2220-0044	Cap Screw (HM3C)
29	4	2220-0021	Cap Screw (HM1C)
29	4	2220-0032	Cap Screw (HM5C)
30	2	1720-0108	O-ring
31	1	3360-0021	Pressure Port Adapter
32	1	3260-0068	Poppet
33	1	1820-0038	Retaining Ring
34	1	3320-0049	Tank Port Adapter
35	1	3220-0029	Bypass Adjusting Screw
36	1	1700-0047	Gasket
37	1	2270-0027	Washer
38	1	2250-0038	Lock Nut
40	1	1610-0055	Roll Pin (HM3C Models)
40	1	1610-0031	Roll Pin (HM1C and HM5C Models)
41	1	1610-0012	Woodruff Key
42	1	2270-0071	Washer

The Spray Tech part number can be derived by adding the prefix 'HY' to the listed Hypro numbers.

All 9306 Stainless Steel Series

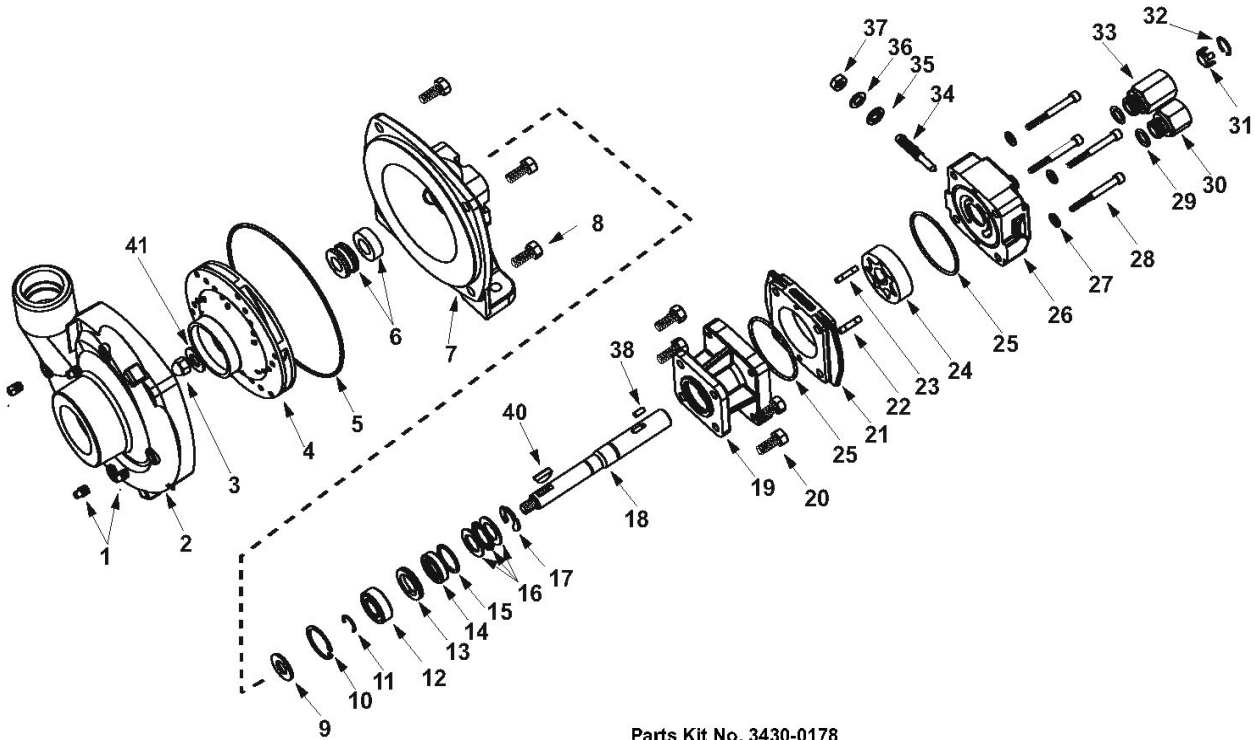

**Silicon Carbide Seal Kit
No. 3430-0589**

Contains one each:
mechanical seal (Ref. 5) and
o-ring (Ref. 6).

Hydraulic Motor Part Nos.

2500-0009C (HM1C Models)
2500-0011C (HM3C Models)
2500-0018C (HM5C Models)

Parts Kit No. 3430-0178

Contains: One each ball bearing
(Ref. 12), motor shaft seal (Ref.
14), thread seal gasket (Ref. 35),
and washer (Ref. 36); two each
motor housing o-rings (Ref. 25),
and port adapter o-rings (Ref. 29).

Ref. No.	Qty. Req'd.	Part No.	Description
1	4	2406-0016	Drain/Vent Plug
2	1	0154-9200S1	Pump Casing (Volute)
3	1	2253-0006	Impeller Nut
4	1	0405-9200P2	Impeller
5	1	1720-0083	O-ring
6	1	3430-0589	Mechanical Seal (Silicon Carbide)
7	1	0750-9300C	Mounting Flange
8	4	2210-0125	Hex Head Cap Screw
9	1	1410-0056	Slinger Ring
10	1	1820-0013	Retaining Ring
11	1	1810-0014	Snap Ring
12	1	2000-0010	Ball Bearing
13	1	1410-0073	Spacer
14	1	2104-0005	Shaft Seal
15	1	1410-0074	Seal Spacer
16	1	2029-0014	Thrust Bearing Assembly - Consists of: (1) Thrust Bearing & (2) Thrust Brg. Races
17	1	1810-0026	Snap Ring
18	1	0510-2500	Shaft (HM3C Model) 7-1/2" long
18	1	0511-2501	Shaft (HM1C & HM5C Models) 7" long
19	1	0151-2500C	Motor Body (Includes Main Bearing)
20	4	2210-0005	Hex Head Cap Screw
21	1	0700-2500C1	Gerotor Housing (HM1C Model) 1/2" wide
21	1	0702-2500C1	Gerotor Housing (HM3C Model) 1" wide
21	1	0704-2500C1	Gerotor Housing (HM5C Model) 5/8" wide

Ref. No.	Qty. Req'd.	Part No.	Description
22	1	1600-0052	Dowel Pin (HM3C Models)
22	1	1600-0044	Dowel Pin (HM1C and HM5C Models)
23	1	1600-0068	Dowel Pin (HM3C Model)
23	1	1600-0037	Dowel Pin (HM1C and HM5C Models)
24	1	3900-0022	Gerotor (HM1C Model)
24	1	3900-0024	Gerotor (HM3C Model)
24	1	3900-0048	Gerotor (HM5C Model)
25	2	1720-0110	O-ring
26	1	0251-2500C2	Motor End Plate (Includes Main Bearing)
27	4	2270-0039	Washer
28	4	2220-0044	Cap Screw (HM3C)
28	4	2220-0021	Cap Screw (HM1C)
28	4	2220-0032	Cap Screw (HM5C)
29	2	1720-0108	O-ring
30	1	3360-0021	Pressure Port Adapter
31	1	3260-0068	Poppet
32	1	1820-0038	Retaining Ring
33	1	3320-0049	Tank Port Adapter
34	1	3220-0029	Bypass Adjusting Screw
35	1	1700-0047	Gasket
36	1	2270-0027	Washer
37	1	2250-0038	Lock Nut
38	1	1610-0031	Roll Pin (HM1C and HM5C Models)
38	1	1610-0055	Roll Pin (HM3C Models)
40	1	04432	Woodruff Key (Stainless)
41	1	2270-0071	Washer

The Spray Tech part number can be derived by adding the prefix 'HY' to the listed Hypro numbers.

Model 9307C

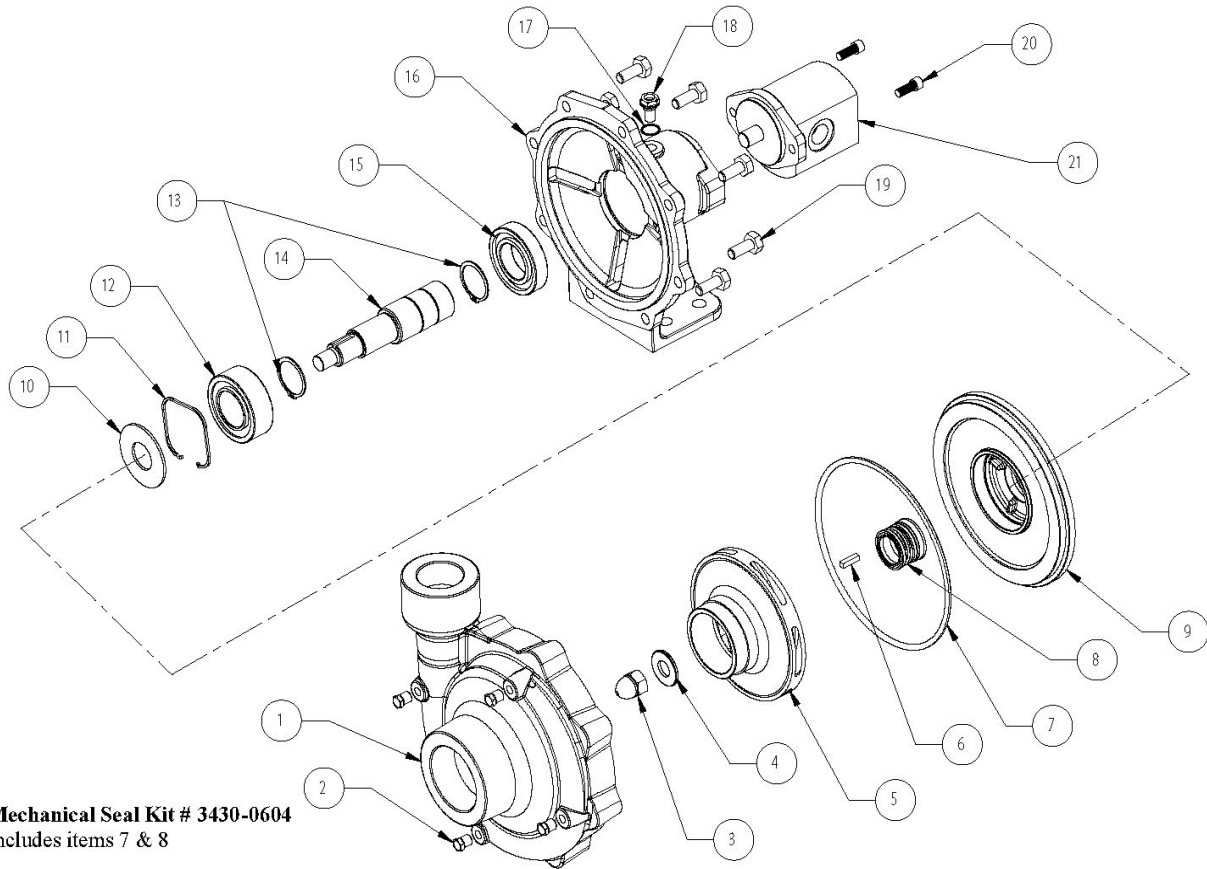

Mechanical Seal Kit # 3430-0604
Includes items 7 & 8

Bearing Kit # 3430-0671
Includes items 10, 11, 12, 13, & 15

Impeller Hardware Kit #3430-0612
Includes items 3, 4, & 6

Hydraulic Motor Seal Replacement #3430-0611
For seal replacement in motor # 2500-0036 (GM10)

Hydraulic Motor Seal Replacement #3430-0616
For seal replacement in motor # 2500-0046 (GM12)

Ref. No.	Qty. Req'd	Part No.	Description
1**	1	0151-9300C	Pump Casing
2	4	2406-0039	Pipe Plug
3	1	2253-0010	Acorn Nut
4	1	2270-0094	Washer
5	1	0400-9300S	Impeller
6	1	1610-0058	Key
7	1	1721-0208	O-Ring
8	1	2120-0043	Mechanical Seal
9	1	0755-9300C	Seal Flange
10	1	2270-0093	Slinger
11	1	1820-0040	Retaining Ring

Ref. No.	Qty. Req'd	Part No.	Description
12	1	2005-0006	Double Row Ball Bearing
13	2	1810-0001	Retaining Ring
14	1	0500-9305	Shaft Assembly
15	1	2007-0063	Ball Bearing
16	1	0757-9300C	Mounting Flange
17	1	1720-0209	O-Ring
18	1	2300-0040	Plug
19	8	2210-0131	Bolt
20	2	2210-0026	Bolt
21	1	2500-0036	Hydraulic Motor (GM10)
21	1	2500-0046	Hydraulic Motor (GM12)

*Includes a Stainless Steel Wear Ring and 4 Pipe Plugs Ref. No. 2

**Used in -U "Universal Flange" models; includes Stainless Steel Wear Ring and 4 Pipe Plugs Ref. No. 2

The Spray Tech part number can be derived by adding the prefix 'HY' to the listed Hypro numbers.

Models 9510P and 9513P

(CW Rotation when viewed from shaft end)

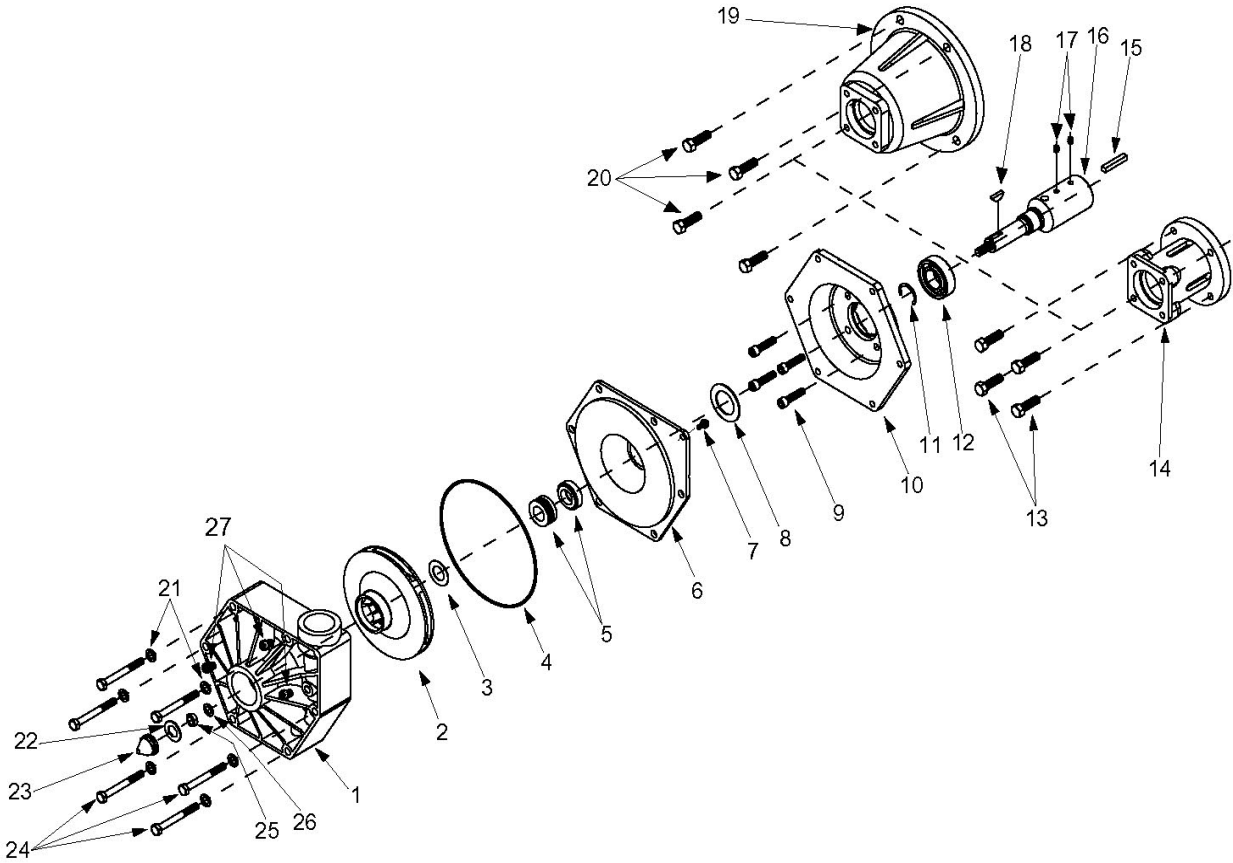

Seal Kit for 9510P, 9513P
No. 3430-0333 consists of:
(1) Ref. 3 Gasket
(1) Ref. 4 O-ring
(1) Ref. 5 Mechanical Seal
(1) Ref. 22 Gasket
(1) Ref. 26 Washer

Ref. No.	Qty. Req'd	Part No.	Description
1	1	0701-9500P	Pump Casing
2	1	0402-9000P	Impeller (Polypropylene)
3	1	1700-0101	Gasket
4	1	1721-0083	O-Ring
5	1	2120-0011	Mechanical Seal
6	1	0700-9500P	Back Cover
7	1	2210-0088	Screw
8	1	1410-0082	Spacer
9	4	2220-0055	Socker Head Capscrew
10	1	0702-9500C	Intermediate Flange
11	1	1810-0013	Retainer Ring
12	2	2008-0001	Bearing
13	4	2210-0077	Hex head bolt
14	1	0705-9500C	Flange (Model 9513P)
15	1	1610-0005	Key (9510P)

Ref. No.	Qty. Req'd	Part No.	Description
15	1	1610-0004	Key (9513P)
16	1	0508-9500	416 Stainless Shaft (Model 9513P)
16	1	0505-9500	Shaft (Model 9510P)
17	2	2230-0017	Set Screw
18	1	1610-0042	Woodruff Key (316 SS)
19	1	0703-9500C	Flange (Model 9510P)
20	4	2210-0026	Hex head bolt
21	6	2270-0041	Washer
22	1	1700-0097	Gasket
23	1	2250-0052	Impeller Nut
24	6	2210-0087	Hex Head Capscrew
25	1	2250-0051	Jam Nut
26	1	2270-0057	Washer
27	4	2406-0020	Plug

The Spray Tech part number can be derived by adding the prefix 'HY' to the listed Hypro numbers.

Model 9402C, 9403C, 9403S and 9403C-SP

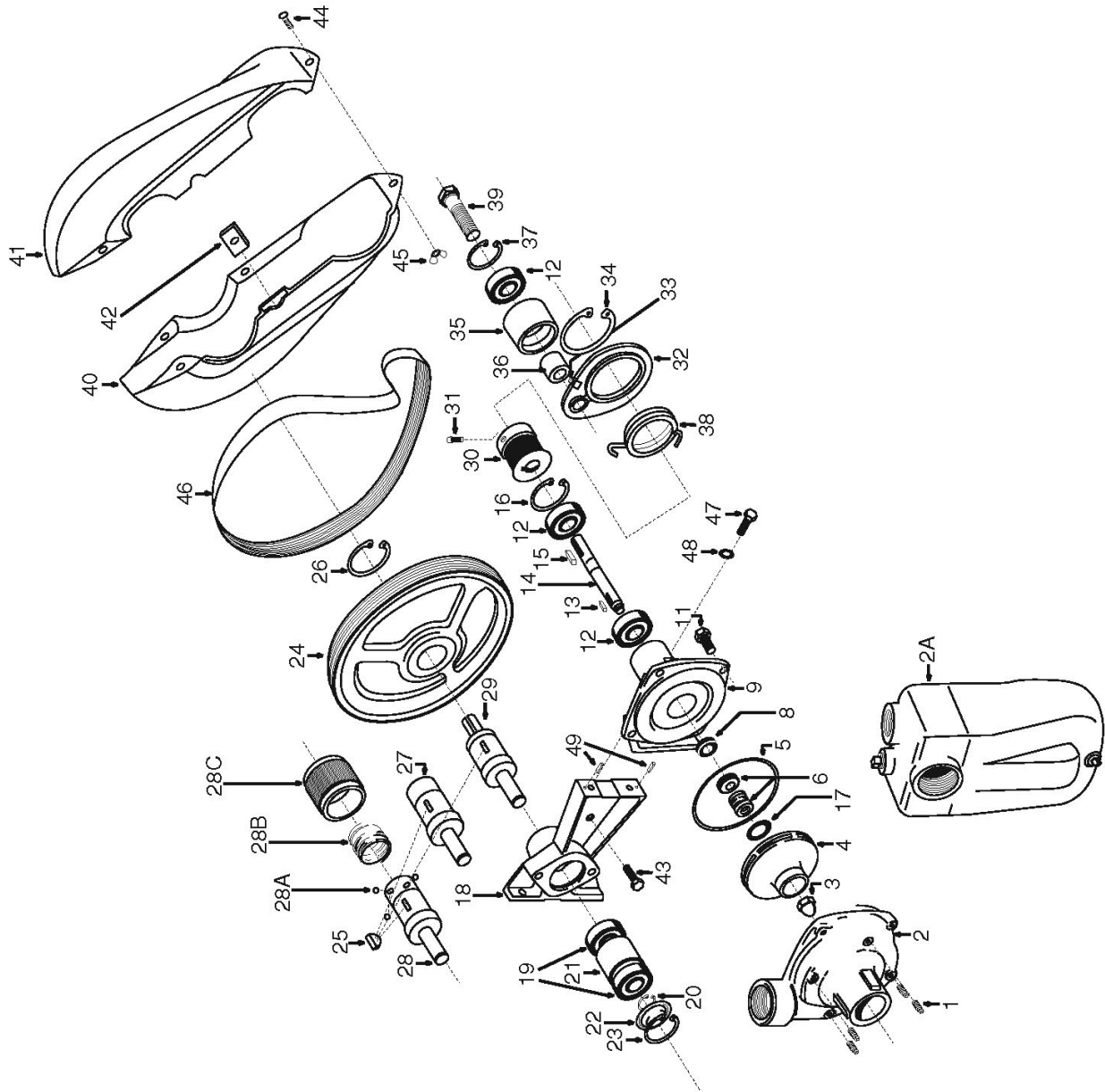

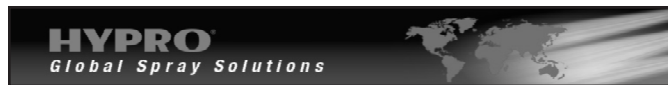

Series 9402C, 9403C, 9403S and 9403C-SP

Ref. No.	Qty. Req'd	Part No.	Description
1	4	2406-0007	Drain Plug
2	1	0150-9000C	Pump Casing (Model 9403C)
2	1	0150-9000S1	Pump Casing (Model 9403S)
2	1	0150-9200C	Pump Casing (Model 9402C)
2A	1	3430-0480SP	Pump Casing (Model 9403C-SP) (The above casings include a stainless steel wear ring.)
3	1	2253-0002	Impeller Nut
3	1	2253-0006	Impeller Nut (Model 9403S)
4	1	0401-9100P	Impeller (Nylon) (standard)
4	1	0402-9100P	Impeller (Polypropylene) (9403S std.)
5	1	1720-0083	O-Ring
6	1	2120-0008	Mechanical Seal (optional Buna-N)
6	1	2120-0009	Mechanical Seal (standard Viton)
6	1	3430-0589	Mechanical Seal (opt. Silicon Carbide)
8	1	1410-0056	Slinger Ring
9	1	0750-9200C	Mounting Flange
9	1	0750-9200S	Mounting Flange (Model 9403S)
10	1	6031-0252	Nameplate (Specify Model Number)
11	4	2210-0020	Bolt
11	4	2210-0125	Bolt (Model 9403S)
12	3	2000-0010	Ball Bearing
13	1	1610-0015	Key
14	1	0505-9200	Pump Shaft
15	1	1610-0004	Key
16	1	1820-0013	Bearing Retainer
17	1	1700-0100	Gasket
18	1	0703-9400D	Pedestal Bracket
19	2	2001-0006	Driver Shaft Bearings
20	1	1810-0012	Driver Shaft Bearing Retainer Ring
21	1	1410-0094	Bearing Spacer
22	1	2840-0053	End Cap (label)
23	1	1820-0032	Bearing Bore Retaining Ring
24	1	3115-0031	Driver Pulley (540 rpm)
24	1	3115-0032	Driver Pulley (1000 rpm)
24	1	3115-0033	Driver Pulley (1000 rpm, 1-3/4" shaft)
25	1	1610-0033	Key (Driver Pulley)
25	1	1610-0034	Key (Driver Pulley, 1-3/4" shaft)
26	1	1810-0031	Retaining Ring (Driver Pulley)
26	1	1810-0032	Retain. Ring (Dr. Pulley, 1-3/4" shaft)
27	1	0555-9400F	Shaft (540 rpm)(3430-0207 kit used on 0555-9400F and 0556-9400F shafts)
27	1	0556-9400F	Shaft (1000 rpm) (3430-0207 kit used on 0555-9400F and 0556-400F shafts)
27	1	0557-9400F	Shaft (1-3/4" 1000 rpm) (3430-0190 kit used on 0557-9400F shaft)
28	1	0555-9400F1	Shaft (540 Quick Coupler)

Ref. No.	Qty. Req'd.	Part No.	Description
28A	3	3250-0004	Locking Ball
28B	1	1900-0115	Collar Spring
28C	1	1400-0021	Collar
29	1	0503-9400	Shaft (1" solid)
30	1	3115-0034	Driven Pulley (5/8" dia. bore)
31	2	2230-0003	Set Screw for Driven Pulley
32	1	0706-9400C	Idler Bracket (Cast Iron Pumps)
33	1	2405-0003	Grease Zerk Fitting
34	1	1810-0036	Retaining Ring (Idler Bracket, Cast Iron)
35	1	3115-0036	Idler Pulley
36	1	1410-0095	Spacer (Idler Pulley)
37	1	1820-0013	Retaining Ring (Idler Pulley)
38	1	1900-0156	Torsion Spring (Idler for Cast Iron)
39	1	2210-0111	Idler Bolt/Shaft
40	1	2840-0075	Belt Shield
41	1	2840-0076	Belt Shield
42	1	1520-0062	Bracket for Belt Shield
43	1	2210-0021	Attachment Bolt for Shield
44	4	2240-0017	Assembly Bolts for Shield
45	4	2252-0002	Assembly Nuts for Shield
46	1	3100-0006	Poly V-Belt (540 rpm)
46	1	3100-0005	Poly V-Belt (1000 rpm)
47	2	2210-0055	Bolts for Pump to Bracket
48	2	2260-0006	Lock Washers for Bracket Bolts
49	2	1600-0070	Roll Pin

Repair Kit No. 3430-0476
(for 540 rpm drives)
consists of (1) Ref. 46 Poly V-Belt, (1) Ref. 5 O-ring, (1) Ref. 6 Mechanical Seal (Viton) and (1) Ref. 17 Gasket.

Repair Kit No. 3430-0477
(for 1000 rpm drives)
consists of (1) Ref. 46 Poly V-Belt, (1) Ref. 5 O-ring, (1) Ref. 6 Mechanical Seal (Viton) and (1) Ref. 17 Gasket.

Seal Repair Kit No. 3430-0332 consists of (1) Ref. 6 Mechanical Seal (Viton-Std.), (1) Ref. 5 O-ring and (1) Ref. 17 Gasket.

Seal Repair Kit No. 3430-0589 consists of (1) Ref. 6 Mechanical Seal (Silicon Carbide-optional) and (1) Ref. 5 O-ring.

The Spray Tech part number can be derived by adding the prefix 'HY' to the listed Hypro numbers.

Models 1536,1537,1538,1539 and 1540

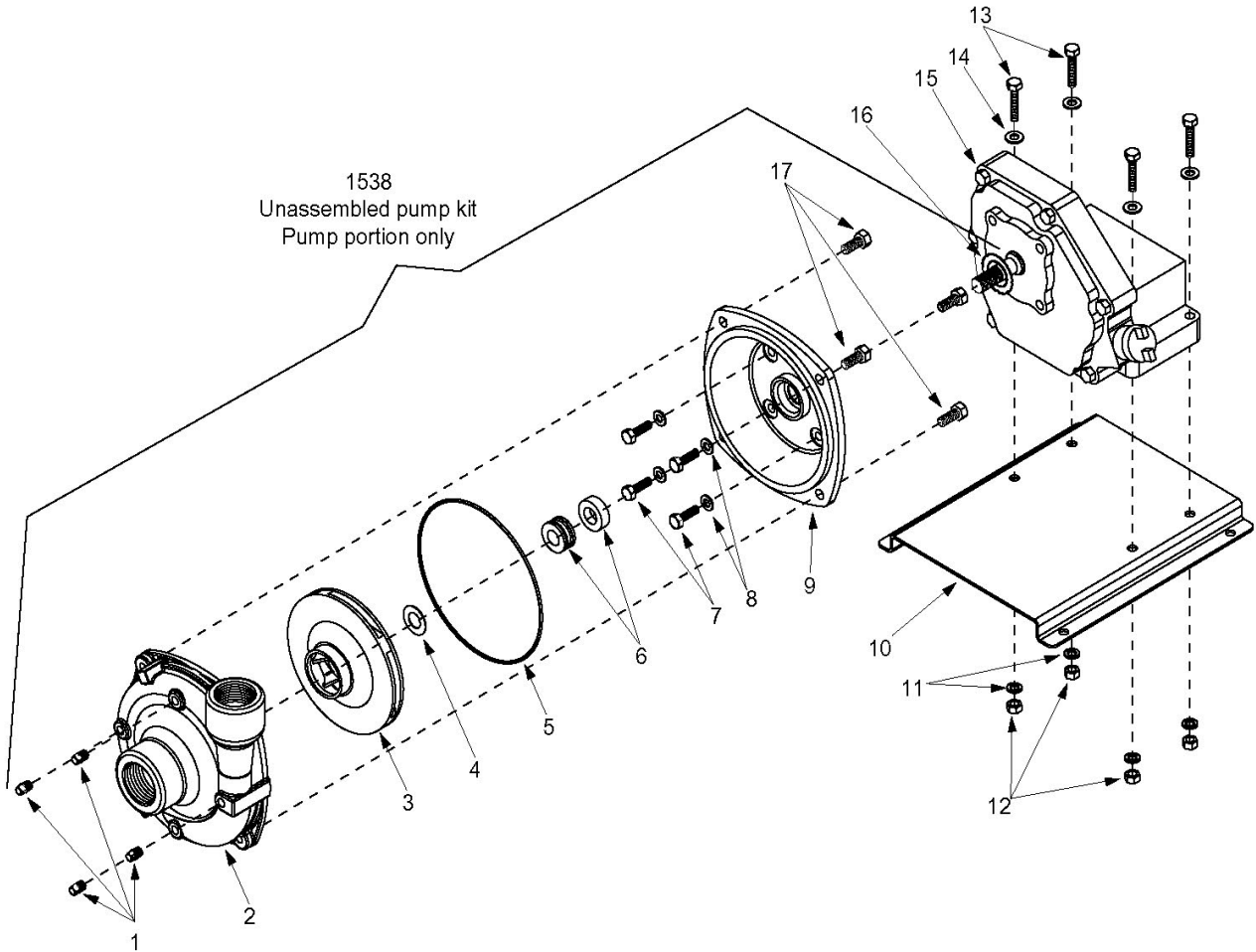

Seal Kit for 1536 thru 1540 (Std.) No. 3430-0332 consists of: (1) Ref. 4 Gasket (1) Ref. 5 O-Ring (1) Ref. 6 Mechanical seal	Seal Kit for 1536 thru 1540 (Opt.) No. 3430-0589 (Silicon carbide) consists of: (1) Ref. 5 O-Ring (1) Ref. 6 Mechanical seal
------------------------------------------------------------------------------------------------------------------------------------------	------------------------------------------------------------------------------------------------------------------------------------------

Ref. No.	Qty. Req'd.	Part No.	Description
1	4	2406-0007	Drain Plug
2	1	0152-9000C	Pump Casing (with SS wear ring)
3	1	0402-9200P	Impeller (Nylon)
4	1	1700-0100	Gasket
5	1	1720-0083	O-ring
6	1	2120-0009	Mechanical Seal - Viton
7	4	2210-0098	Bolt
8	4	1700-0119	Seal
9	1	0703-9200C	Flange
10	1	1510-0083	Mounting Plate
11	4	2260-0002	Lock Washer
12	4	2250-0003	Nut

Ref. No.	Qty. Req'd.	Part No.	Description
13	4	2210-0021	Bolt
14	4	2270-0040	Washer
15	1	2541-0033 (135232-0035-01)*	Briggs & Stratton Engine (Model 1536 and 1539)
15	1	2541-0034 GX160K1 Type-TX2*	Honda Engine (Model 1537)
15	1	2541-0035 GX160KIT1C3	Honda Engine (Model 1540)
16	1	1410-0088	Bearing Shield (5 HP Briggs)
16	1	1410-0105	Bearing Shield (5.5 HP Briggs)
17	4	2210-0020	Bolt

* Contact the engine manufacturer for this product number.

The Spray Tech part number can be derived by adding the prefix 'HY' to the listed Hypro numbers.

Models 1550, 1550-SP, 1550-BSP. 1551, 1551-SP, 1551-BSP

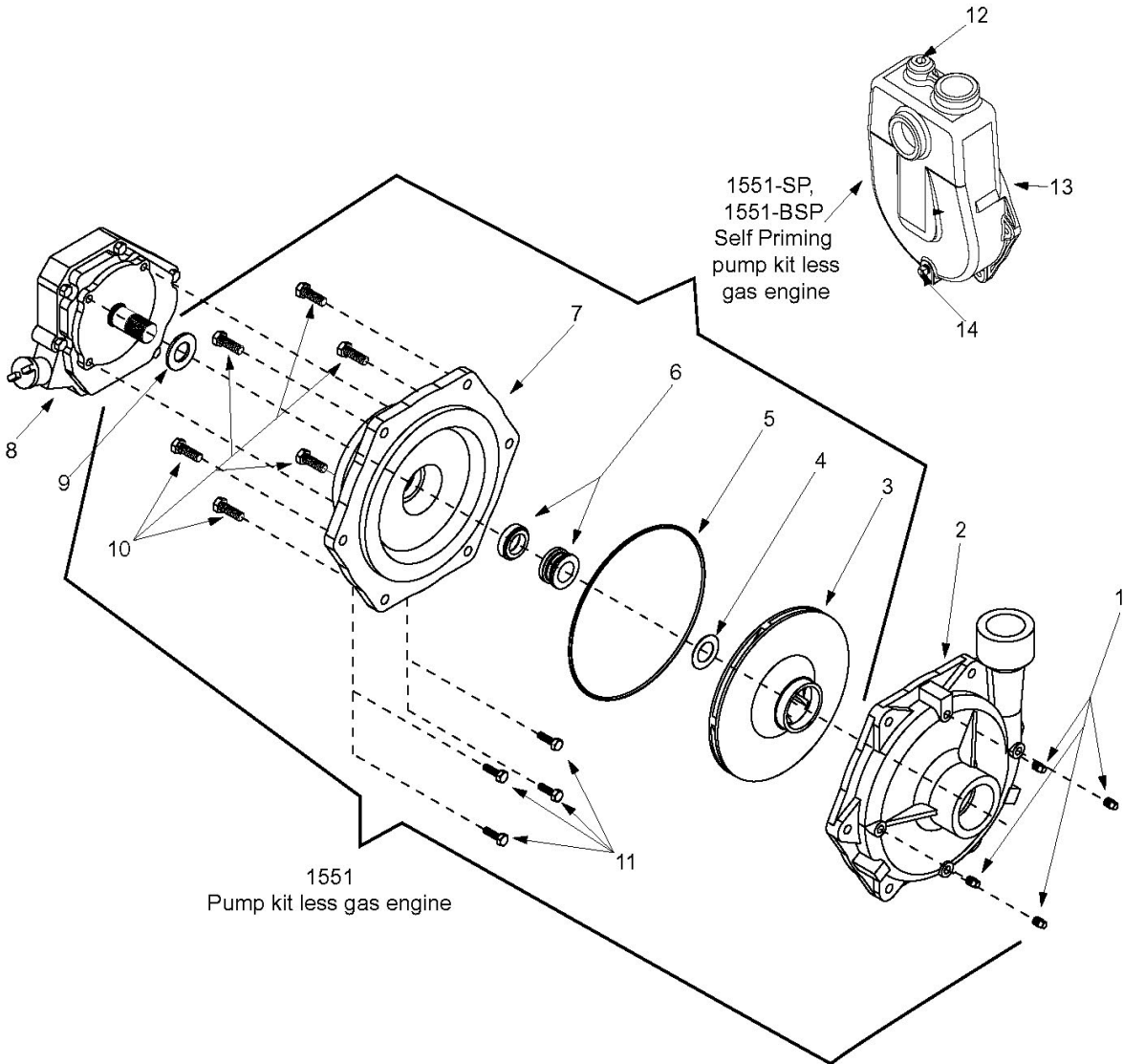

Seal Kit for 1550 and 1551
No. 3430-0464 consists of:
(1) Ref. 4 Gasket
(1) Ref. 5 O-ring
(1) Ref. 6 Mechanical Seal

Ref. No.	Qty. Req'd	Part No.	Description
1	4	2406-0007	Drain Plug
2	1	0153-9200C	Pump Casing (Includes SS wear ring)
3	1	0404-9200P	Impeller (Nylon)
4	1	1700-0121	Gasket
5	1	1720-0180	O-Ring
6	1	2120-0034	Mechanical Seal - Viton
7	1	0707-9200C	Flange
8	1	2541-0037	Honda eng. (Model 1550) (GX-270PA)*

Ref. No.	Qty. Req'd	Part No.	Description
9	1	1410-0091	Slinger Ring
10	6	2210-0086	Bolt
11	4	2210-0098	Bolt
12	1	2406-0034	Priming port plug (Standard)
12	1	2406-0036	Priming port plug (BSP)
13	1	0152-9075C	Pump Casing (Standard NPT)
13	1	0152-9075C1	Pump Casing (BSP)
14	1	2406-0002	Drain plug

* CONTACT THE ENGINE MANUFACTURER FOR THIS PRODUCT NUMBER

The Spray Tech part number can be derived by adding the prefix 'HY' to the listed Hypro numbers.

1542P-5SP Gasoline Engine-Driven Plastic Transfer Pump

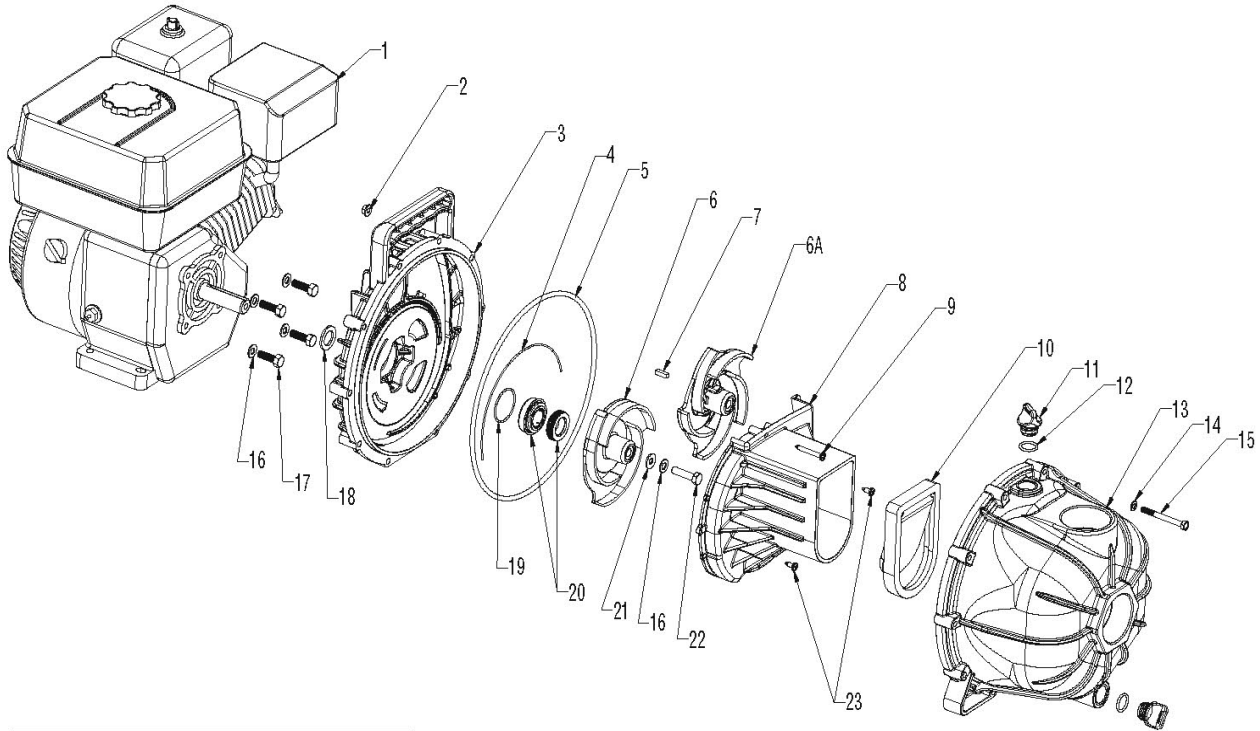

Seal Repair Kit 3430-0635 contains:
 (1) Ref. 4 Diffuser Gasket, (1) Ref. 5 Pump Body O-Ring, (1) Ref. 19 Seal O-Ring, (1) Ref. 20 Mechanical Seal, and (1) Ref. 21 Impeller Gasket

Viton Seal Repair Kit 3430-0659 contains:
 (1) Ref. 4 Diffuser Gasket, (1) Ref. 5 Pump Body O-Ring, (1) Ref. 10 Flapper Valve, (1) Ref. 19 Seal O-Ring, (1) Ref. 20 Mechanical Seal, and (1) Ref. 21 Impeller Gasket

Pump Head Kit 3430-0637 (1542P-3SP) Includes all items less 1, 6A and 7.

Pump Head Kit 3430-0648 (1542P-5SP) Includes all items less 1 and 6.

Optional Viton Pump Head Kit 3430-0660 (1542P-3SP) Includes all items less 1, 6A and 7.

Optional Viton Pump Head Kit 3430-0661 (1542P-5SP) Includes all items less 1 and 6.

Ref#	Torque Spec.
#17	10 ft-lbs.
#22	10 ft-lbs.
#15	45 in-lbs.

REF. NO.	QTY.	PART NO.	DESCRIPTION
1	1	2549-0039	5.5 HP PowerPro Gas Engine (1542P-3SP)
1A	1	2549-0041	6.5 HP PowerPro Gas Engine (1542P-5SP)
2	10	2250-0087	Hex Flange Nut, M6
3	1	0750-1540P	Mounting Flange
4	1	1700-0209	Diffuser Gasket
5	1	1720-0229	Pump Body O-Ring
6	1	0400-1540P	3 Vane Impeller (1542P-3SP)
6A	1	0401-1540P	5 Vane Impeller (1542P-5SP)
7	1	1610-0044	Key 3/16 X 5/8 SS (1542P-5SP)
8	1	0150-1540P	Diffuser
9	1	2210-0144	Diffuser Mounting Screw (Long)
10	1	1700-0208	Flapper Valve
11	2	2404-0350P	Fill/Drain Plug

REF. NO.	QTY.	PART NO.	DESCRIPTION
12	2	1720-0035	Plug O-Ring
13	1	0100-1540P	Pump Housing
14	10	2270-0115	Flat Washer 6M
15	10	2210-0141	Bolt 6M X1 X 60
16	5	2270-0114	Washer 5/16 SS
17	4	2210-0143	Mounting Bolt 5/16-24 X 1
18	1	1410-0083	Slinger Ring
19	1	1720-0231	Seal O-Ring
20	1	2120-0044	Mechanical Seal
21	1	1700-0210	Impeller Gasket
22	1	2210-0142	Impeller Bolt 5/16-24 X 1-1/4
23	2	2210-0145	Diffuser Mounting Screw (Short)

The Spray Tech part number can be derived by adding the prefix 'HY' to the listed Hypro numbers.

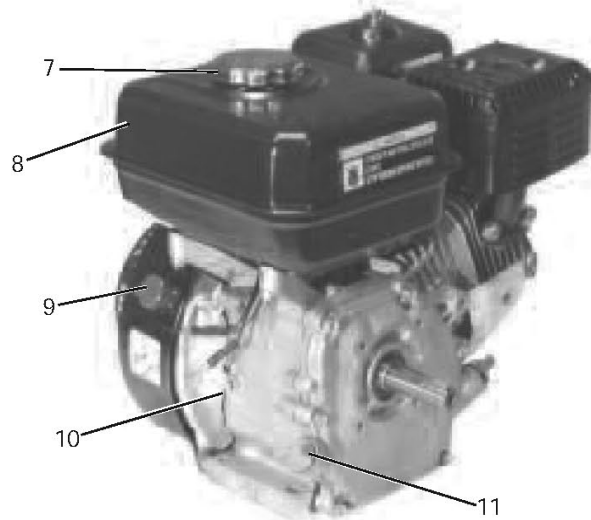
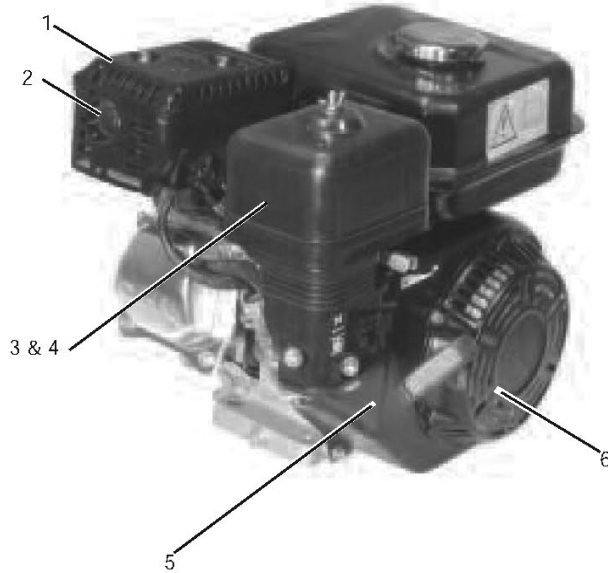

**Engine Gasket Kit
No. 2545-0015**

Includes:

- Head Cover Gasket
- Exhaust Pipe Gasket
- Crank Oil Seal
- Crankcase Cover Gasket
- Carb Gaskets (3)

Item	Description	Qty.	Part Number
1	Muffler Cover	1	2545-0011
2	Muffler	1	2545-0010
3	Air Cleaner Cover	1	2545-0006
4	Air Cleaner Element	1	2545-0001
5	Fan Cover	1	2545-0007
6	Recoil Assembly (includes rope, handle and recoil assembly)	1	2545-0005
7	Fuel Cap	1	2545-0002
8	Fuel Tank	1	2545-0009
9	ON/OFF Switch	1	2545-0004
10	Low Oil Sensor	1	2545-0008
11	Oil Dipstick	1	2545-0003
	Ignition Module (not shown)	1	2545-0014
	Carburetor - full assembly (not shown)	1	2545-0017

The Spray Tech part number can be derived by adding the prefix 'HY' to the listed Hypro numbers.



Models 5206C and 5210C

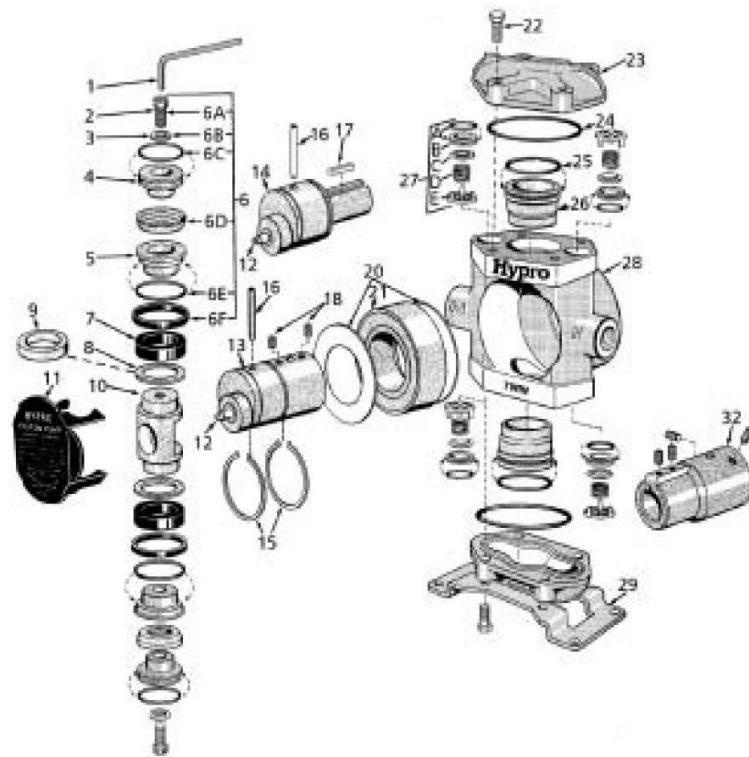

Piston Stack Parts Kits

Leather Cup Kit No. 3430-0037 (STD)

Consists of two each of the following parts: No. 2220-0013 Piston Cap Screw (Ref. 6A), No. 2270-0012 Washer (Ref. 6B), No. 1720-0030 O-Ring (Ref. 6C), No. 2150-0001 Leather Cup (Ref. 6D), No. 1720-0065 O-Ring (Ref. 6E) and No. 1440-0012 Seal Ring (Ref. 6F).

Fabric Cup Kit No. 3430-0039

Same as Leather Cup Kit except with two No. 2150-0012 Fabric Cups.

Rubber Cup Kit No. 3430-0189

Same as Leather Cup Kit except with two No. 2150-0042 Rubber Cups.

Crankshaft Assemblies

Sub-Assemblies

Include Grease Fitting (Ref. 12), Crankshaft with cam bearing (Ref. 13 or 14) and Crankpin Retainer (Ref. 16).

Complete Assemblies

Include Sub-Assembly components plus Retaining Rings (Ref. 15), slinger rings (Ref. 20) and Bearing (Ref. 21).

Sub-Assembly PART NO.	Complete Assembly PART NO.	Pump Model Number
with 1-3/8" Hollow PTO Shaft (Ref. 13)		
5503-5206	5501-5206	5206C-H
5503-5210	5501-5210	5210C-H
with 1" Solid Shaft (Ref. 14)		
5003-5206	5001-5206	5206C
5003-5210	5001-5210	5210C

Ref. No.	Qty. Req'd.	Part No.	Description
1	1	3020-0008	Allen Wrench (Optional)
2	2	2220-0013	Piston Cap Screw
3	2	2270-0012	Washer
4	2	1830-0039	Piston Cup Spreader
5	2	1410-0054	Cup Backing Plate
6	1	3430-0037	Piston Stack Parts Kit with Leather Cups (Standard)
6	1	3430-0039	Piston Stack Parts Kit with Fabric Cups (Models 5200-F)
6	1	3430-0189	Piston Stack Parts Kit with Buna-N Cups (Models 5200-R)
7	2	1440-0005	Piston Guide
8	2	1410-0018	Support Ring For 5210 Models Only
9	2	1410-0020	Support Ring For 5206 Models Only
10	1	0503-5200	Connecting Rod
11	1	0602-5200	Safety Cover
12	1	2405-0006	Grease Fitting Assembly
13	1	See Listing	Crankshaft (Hollow Shaft Models)
14	1	See Listing	Crankshaft (Solid Shaft Models)
15	2	1810-0001	Retainer Ring
16	1	1600-0013	Crankpin Retainer

Ref. No.	Qty. Req'd.	Part No.	Description
17	1	1810-0005	Key (Solid Shaft Models)
18	2	2230-0003	Set Screw
20	2	1410-0006	Slinger Ring
21	1	2005-0002	Main Bearing
22	8	2210-0062	Cylinder Head Bolt
23	2	0203-5200CB	Cylinder Head
24	2	1720-0028	O-Ring – for cylinder head
25	2	1720-0019	O-Ring – for cylinder sleeve
26	2	3550-0007	Cylinder Sleeve
27	4	3400-0038	Valve Assembly—Consists of: O-ring (Ref. A), Valve Seat (Ref. B), Valve Poppet (Ref. C), Valve Spring (Ref. D) and Valve Spring Retainer (Ref. E)
28	1	0100-5200C	Body
29	1	1510-0024	Base
32	1	1320-0081	Adapter-Adapts 1" solid shaft to 1-3/8" 6-spline PTO hollow shaft. (Includes set screws.)

The Spray Tech part number can be derived by adding the prefix 'HY' to the listed Hypro numbers.

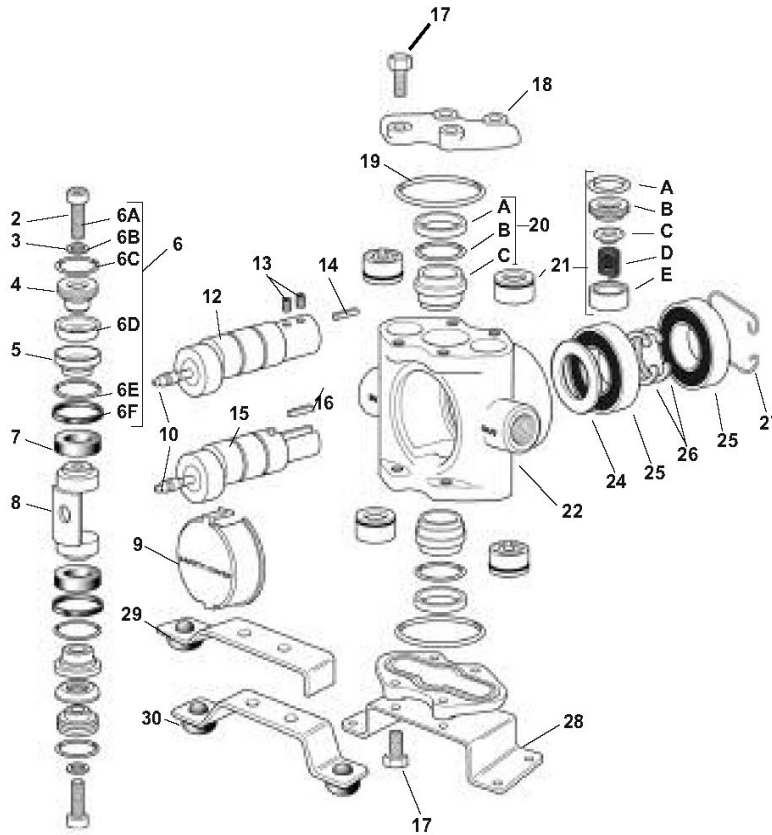

Piston Stack Parts Kit

Leather Cup Kit No. 3430-0007

Consists of two each of the following parts: No. 2220-0012 Piston Cap Screw (Ref. 6A), No. 2270-0011 Washer (Ref. 6B), No. 1720-0029 O-ring (Ref. 6C), No. 2150-0002 Leather Cup (Ref. 6D), No. 1720-0039 O-Ring (Ref. 6E), and No. 1440-0008 Seal Ring (Ref. 6F).

Rubber Cup Kit No. 3430-0009

Same as above kit except with No. 2150-0005 Rubber Cups.

Piston Stack and Guide Parts Kits

Leather Cup and Guide Kit No. 3430-0008

Consists of Leather Cup Kit No. 3430-0007 plus two No. 1440-0004 Piston Guides (Ref. 7).

Rubber Cup and Guide Kit No. 3430-0010

Consists of Rubber Cup Kit No. 3430-0009 plus two No. 1440-0004 Piston Guides.

Teflon Cup and Guide Kit No. 3430-0046

Consists of Teflon Cup Stack Kit plus 2 Piston Guides.

Crankshaft Assemblies

Sub-Assemblies include Shaft (Ref. 12 or 15) with Cam Bearing, Grease Fitting Assembly (Ref. 10), Set Screws for Hollow Shaft (Ref. 13) and Spline Key (Ref. 14 or 16).

Complete Assemblies include the Sub-Assembly plus parts identified by Reference Numbers 24-26.

Sub-Assembly Part No.	Complete Assembly Part No.	Pump Model
with 5/8" (I.D.) Hollow Shaft (Ref. 12)		
5501-5315	5500-5315	5315C-H
5501-5320	5500-5320	5320C-H
5501-5325	5500-5325	5325C-H
5501-5330	5500-5330	5330C-H
with 5/8" Solid Shaft (Ref. 15)		
5001-5315	5000-5315	5315C
5001-5320	5000-5320	5320C
5001-5325	5000-5325	5325C
5001-5330	5000-5330	5330C

Ref. No.	Qty. Req'd.	Part No.	Description
2	2	2220-0012	Piston Cap Screw
3	2	2270-0011	Washer
4	2	1830-0017	Piston Cup Spreader
5	2	1410-0030	Cup Backing Plate
6	1		Piston Stack Parts Kit (see listing above)
7	2	1440-0004	Piston Guide
8	1	0502-5300	Connecting Rod
9	1	0608-5300	Safety Cover
10	1	2405-0006	Grease Fitting Assembly
12	1		Crankshaft Assemblies — Hollow Shaft Models, see listing above
13	2	2230-0017	Set Screw for Hollow Shaft
14	1	1610-0011	Spline Key for Hollow Shaft
15	1		Crankshaft Assemblies — Solid Shaft Models, see listing above
16	1	1610-0007	Spline Key for Solid Shaft
17	8	2210-0062	Cylinder Head Bolt
18	2	0204-5300C	Cylinder Head (Cast Iron)
19	2	1720-0038	O-ring for Cylinder Head
20	1	3430-0209	Ni-Resist Cylinder Sleeve Assembly Consists of two each of No. 1830-0033 Retainer (Ref. A), No. 1720-0079 O-ring (Ref. V), and No. 3550-0018 Sleeve (Ref. C)

Ref. No.	Qty. Req'd.	Part No.	Description
21	1 set	3430-0197	Set of four No. 3400-0073 Unitized Valve Assemblies: Consists of four each: O-ring (Ref. A), Valve Seat (Ref. B), Valve Poppet (Ref. C), Valve Spring (Ref. D), Valve Spring Retainer (Ref. E)
22	1	0108-5300C	Body (Cast Iron)
24	1	2130-0007	Bearing Shield
25	2	2008-0001	Main Bearing (Ball Bearing)
26	2	1810-0013	Bearing Retainer Ring (shaft)
27	1	1820-0025	Bearing Retainer Ring (housing)
28	1	1510-0056	Mounting Base
29	1	2820-0040	Torque Arm — for Electric Motor Mounting
30	1	2820-0042	Torque Arm — for Gas Engine Mounting

The Spray Tech part number can be derived by adding the prefix 'HY' to the listed Hypro numbers.

Models 5321C and 5322C

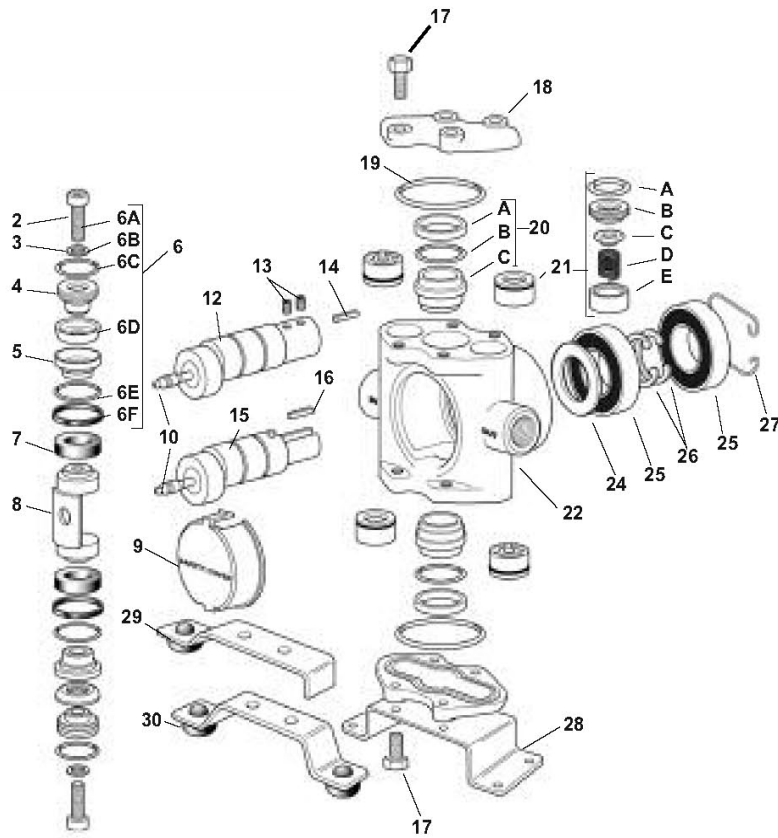

Piston Stack Parts Kit

Leather Cup Kit No. 3430-0007

Consists of two each of the following parts: No. 2220-0012 Piston Cap Screw (Ref. 6A), No. 2270-0011 Washer (Ref. 6B), No. 1720-0029 O-ring (Ref. 6C), No. 2150-0002 Leather Cup (Ref. 6D), No. 1720-0039 O-Ring (Ref. 6E), and No. 1440-0008 Seal Ring (Ref. 6F).

Rubber Cup Kit No. 3430-0009

Same as above kit except with No. 2150-0005 Rubber Cups.

Piston Stack and Guide Parts Kits

Leather Cup and Guide Kit No. 3430-0008

Consists of Leather Cup Kit No. 3430-0007 plus two No. 1440-0004 Piston Guides (Ref. 7).

Rubber Cup and Guide Kit No. 3430-0010

Consists of Rubber Cup Kit No. 3430-0009 plus two No. 1440-0004 Piston Guides.

Teflon Cup and Guide Kit No. 3430-0046

Consists of Teflon Cup Stack Kit plus 2 Piston Guides.

Crankshaft Assemblies

Sub-Assemblies include Shaft (Ref. 12 or 15) with Cam Bearing, Grease Fitting Assembly (Ref. 10), Set Screws for Hollow Shaft (Ref. 13) and Spline Key (Ref. 14 or 16).

Complete Assemblies include the Sub-Assembly plus parts identified by Reference Numbers 24-26.

Sub-Assembly Part No.	Complete Assembly Part No.	Pump Model
with 5/8" (I.D.) Hollow Shaft (Ref. 12)		
5501-5315	5500-5315	5315C-H
5501-5320	5500-5320	5320C-H
5501-5325	5500-5325	5325C-H
5501-5330	5500-5330	5330C-H
with 5/8" Solid Shaft (Ref. 15)		
5001-5315	5000-5315	5315C
5001-5320	5000-5320	5320C
5001-5325	5000-5325	5325C
5001-5330	5000-5330	5330C

Ref. No.	Qty. Req'd.	Part No.	Description
2	2	2220-0012	Piston Cap Screw
3	2	2270-0011	Washer
4	2	1830-0017	Piston Cup Spreader
5	2	1410-0030	Cup Backing Plate
6	1		Piston Stack Parts Kit (see listing above)
7	2	1440-0004	Piston Guide
8	1	0502-5300	Connecting Rod
9	1	0608-5300	Safety Cover
10	1	2405-0006	Grease Fitting Assembly
12	1		Crankshaft Assemblies — Hollow Shaft Models, see listing above
13	2	2230-0017	Set Screw for Hollow Shaft
14	1	1610-0011	Spline Key for Hollow Shaft
15	1		Crankshaft Assemblies — Solid Shaft Models, see listing above
16	1	1610-0007	Spline Key for Solid Shaft
17	8	2210-0062	Cylinder Head Bolt
18	2	0204-5300C	Cylinder Head (Cast Iron)
19	2	1720-0038	O-ring for Cylinder Head
20	1	3430-0209	Ni-Resist Cylinder Sleeve Assembly Consists of two each of No. 1830-0033 Retainer (Ref. A), No. 1720-0079 O-ring (Ref. V), and No. 3550-0018 Sleeve (Ref. C)

Ref. No.	Qty. Req'd.	Part No.	Description
21	1 set	3430-0197	Set of four No. 3400-0073 Unitized Valve Assemblies: Consists of four each: O-ring (Ref. A), Valve Seat (Ref. B), Valve Poppet (Ref. C), Valve Spring (Ref. D), Valve Spring Retainer (Ref. E)
22	1	0108-5300C	Body (Cast Iron)
24	1	2130-0007	Bearing Shield
25	2	2008-0001	Main Bearing (Ball Bearing)
26	2	1810-0013	Bearing Retainer Ring (shaft)
27	1	1820-0025	Bearing Retainer Ring (housing)
28	1	1510-0056	Mounting Base
29	1	2820-0040	Torque Arm — for Electric Motor Mounting
30	1	2820-0042	Torque Arm — for Gas Engine Mounting

The Spray Tech part number can be derived by adding the prefix 'HY' to the listed Hypro numbers.

DELAVAN Roller Pumps

Roller Pump 4400 Series

4-Roller Side Port Roller Pumps

- Models:** **4400C** ◇ **Solid shaft, Cast Iron (blue finish)**
4400N ◇ **Solid shaft, Ni-Resist (brown finish)**
4400D **Solid shaft, Diamond™ Series (silver finish)**
4401C ◇ **Hollow shaft, Cast Iron (blue finish)**
4401N ◇ **Hollow shaft, Ni-Resist (brown finish)**
4401D **Hollow shaft, Diamond™ Series (silver finish)**

Universal Repair Kit

44-4000 RK

4-Roller Pump Repair Kit for 4400 and 4401 Pumps

Part #	Description	Qty/ Kit
48234	Roller, Ultra, 1/2" diameter	4
20468	Universal Lip Seal, Viton	2
50047	Lip Seal, Viton	2
31350-138	Universal Seal Ring	1
31350-142	Seal Ring	1

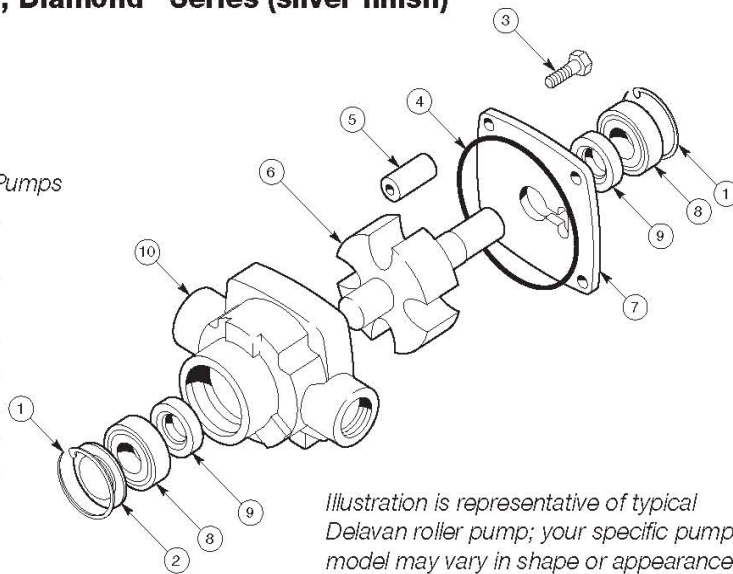

Illustration is representative of typical Delavan roller pump; your specific pump model may vary in shape or appearance.

4400 Series Pump Parts

Ref #	Qty/ Pump	Part #	Description
1	2	15070	Snap Ring
2	1	48237	Nameplate 4400C
		48237-1	Nameplate 4400N
		48237-2	Nameplate 4400D
3	4	48236	Cap Screw
4	1	31350-142	Seal Ring
5	4	48234	Ultra Rollers 1/2"
6	1	32401	Solid Shaft & Rotor (Cast Iron/Ni-Resist)
		32403	Solid Shaft & Rotor (Diamond)
		32402	Hollow Shaft & Rotor (Cast Iron/Ni-Resist)
		32404	Hollow Shaft & Rotor (Diamond)
7	1	48231-1	Endplate (Cast Iron)
		48231-2	Endplate (Ni-Resist)
		48231-3	Endplate (Diamond)
8	2	15072	Bearing STD#6203ZZ
9	2	50047	Lip Seal, Viton
10	1	48229-1	Pump Body (Cast Iron)
		48229-2	Pump Body (Ni-Resist)
		48229-3	Pump Body (Diamond)

Spray Tech part numbers for Delavan pumps and parts should have the prefix "DE" in front of the listed Delavan numbers.

◇ Delavan Cast and Ni-Resist pumps and parts are not standard stock items - special order item.

Series 4400/4401 4-Roller Pumps

Max Flow: 9.2 GPM (35 LPM)

Max Operating Speed: 2600 RPM

Specifications

Pump

Type: 4-roller design

Max Pressure: 150 PSIG (10.5 bar)

Max Recommended Temperature: 140°F (60°C)

Port Size: 3/4" NPT (female)

Mounting:

Base Mounted: 5/16-18 UNC-2B (2 holes)

PTO: Use torque bar and chain (see accessories)

Shaft

Size:

4400: 5/8" solid shaft

4401: 1/2" hollow shaft

Rotation: CW (standard)

(Shaft rotation is determined when looking at shaft end of pump)

Materials of Construction

Housing: Cast Iron, Ni-Resist or Diamond Series™

Rollers: 1/2" Ultra rollers (standard);

Polypropylene (optional)

Shaft Seals: Viton cartridge type lip seals

Seal Ring: Viton

Shaft & Rotor:

Cast Iron & Ni-Resist: Extra-fine finish 404 SST

Diamond Series™: Extra-fine finish 416 SST

Bearings: Permanently-lubricated, heavy-duty sealed bearings

Performance

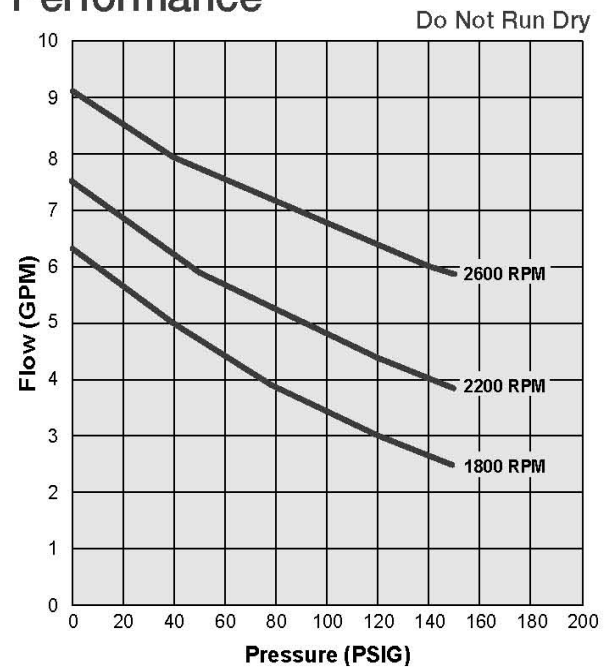

Flow (GPM) @ Specified Pressure and Speed

PSI	1800 RPM	2200 RPM	2600 RPM
0	6.3	7.7	9.2
20	5.8	6.9	8.5
40	5.0	6.2	7.9
60	4.4	5.6	7.5
80	3.8	5.2	7.2
100	3.4	4.8	6.8

Dimensions Inches (mm)

Weight 5 lbs (11 kg)

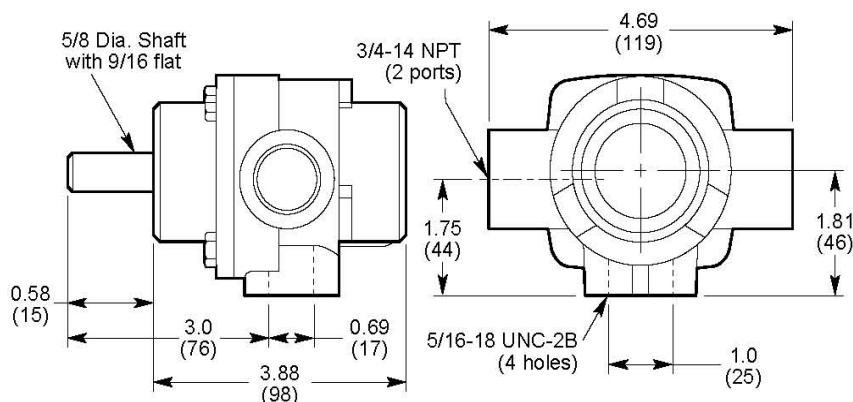

Shaft rotation is determined when looking at shaft end of pump.

Series 4400/4401 4-Roller Pumps

4400/4401 Cast Iron ♦



- 4400 C Cast Iron pump with 5/8" solid shaft; CW rotation
- 4401 C Cast Iron pump with 1/2" hollow shaft; CW rotation

4400/4401 Diamond Series™



"Roundup Ready"®

- 4400 D Diamond Series pump with 5/8" solid shaft; CW rotation
- 4401 D Diamond Series pump with 1/2" hollow shaft; CW rotation

Roundup® is a registered trademark of Monsanto Company

4400/4401 Ni-Resist ♦



- 4400 N Ni-Resist pump with 5/8" solid shaft; CW rotation
- 4401 N Ni-Resist pump with 1/2" hollow shaft; CW rotation

Shaft rotation is determined when looking at shaft end of pump.

Accessories:

See the accessories section for a complete listing

Torque Bar and Chain



Part #: 33680

Required to anchor PTO-mounted pumps in order to keep pump from rotating with the shaft

Coupler



Part #: 50101

For 5/8" diameter electric motor or gas engine shafts; 2600 RPM max. operating speed; mild steel with set screws

Spray Tech part numbers for Delavan pumps and parts should have the prefix "DE" in front of the listed Delavan numbers.

♦Delavan Cast and Ni-Resist pumps and parts are not standard stock items - special order item.

Roller Pump 5500 Series

5-Roller Side Port Roller Pumps

- Models:** 5500C ◇ Cast iron (blue finish)
 5500N ◇ Ni-Resist (brown finish)
 5500D Diamond™ Series (silver finish)

Universal Repair Kit

55-1700 RK

5-Roller Pump Repair Kit for 5500 Pump

Part #	Description	Qty/Kit
48253	Roller, Ultra, 1" diameter	5
47927	Lip Seal, Viton	2
31350-157	Universal Seal Ring	1
48252	Seal Ring	1

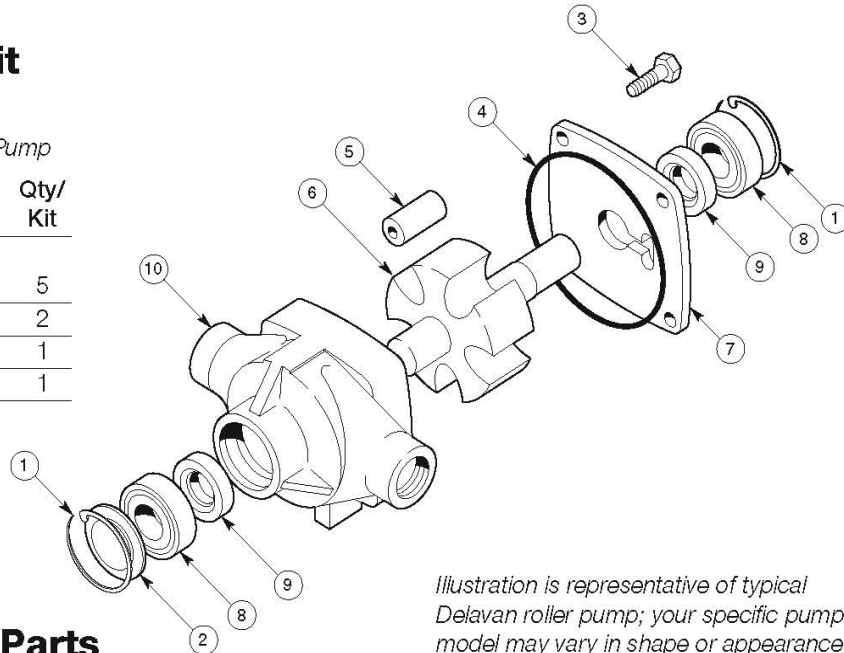

Illustration is representative of typical Delavan roller pump; your specific pump model may vary in shape or appearance.

5500 Series Pump Parts

Ref #	Qty/ Pump	Part #	Description
1	2	15334	Snap Ring
2	1	48255-2	Nameplate 5500C
		48255-1	Nameplate 5500N
		48255-6	Nameplate 5500D
3	4	15341	Cap Screw
4	1	48252	Seal Ring
5	5	48253	Ultra Rollers 1"
6	1	32501	Shaft & Rotor (Cast Iron/Ni-Resist)
		32503	Shaft & Rotor (Diamond)
7	1	48248-1	Endplate (Cast Iron)
		48248-2	Endplate (Ni-Resist)
		48248-3	Endplate (Diamond)
8	2	16228	Bearing STD#6705ZZ
9	2	47927	Lip Seal, Viton
10	1	48246-1	Pump Body (Cast Iron)
		48246-2	Pump Body (Ni-Resist)
		48246-3	Pump Body (Diamond)

Spray Tech part numbers for Delavan pumps and parts should have the prefix "DE" in front of the listed Delavan numbers.

◇ Delavan Cast and Ni-Resist pumps and parts are not standard stock items - special order item.

Series 5500 5-Roller Pumps

Max Flow: 46.5 GPM (176.7 LPM)

Max Operating Speed: 1000 RPM

Specifications

Pump

Type: 5-roller design

Max Pressure: 200 PSIG (14 bar); 100 PSIG (7 bar) for continuous duty at 850 RPM and higher

Max Recommended Temperature: 140°F (60°C)

Port Size: 1" NPT (female)

Mounting:

Base Mounted: 3/8-18 UNC-2B (2 holes)

PTO: Use torque bar and chain (see accessories)

Shaft

Size: 15/16" solid shaft

Rotation: CCW (standard); CW (optional)

(Shaft rotation is determined when looking at shaft end of pump)

Materials of Construction

Housing: Cast Iron, Ni-Resist or Diamond Series™

Rollers: 1" Ultra rollers (standard);

Polypropylene (optional)

Shaft Seals: Viton cartridge type lip seals

Seal Ring: Viton

Shaft & Rotor:

Cast Iron & Ni-Resist: Extra-fine finish 404 SST

Diamond Series™: Extra-fine finish 416 SST

Bearings: Permanently-lubricated, heavy-duty sealed bearings

Performance

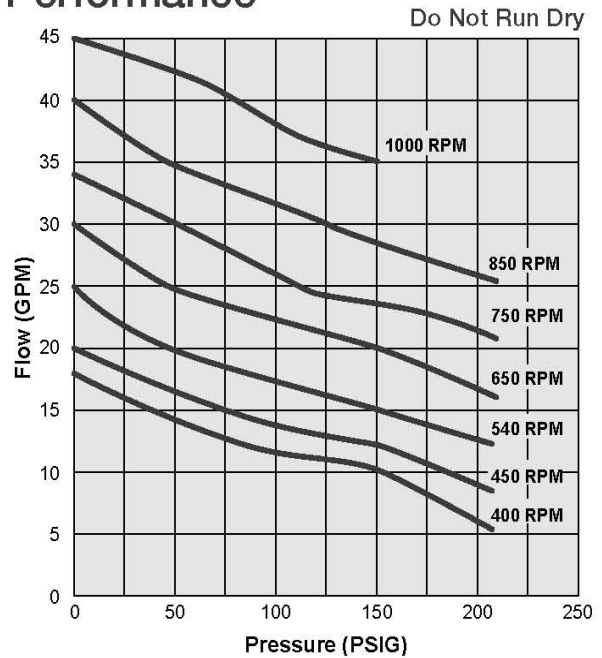

Flow (GPM) @ Specified Pressure and Speed

PSI	540 RPM	850 RPM	1000 RPM
0	25.0	41.0	46.5
50	21.0	37.1	43.3
100	19.1	34.3	41.7
150	17.4	30.1	39.0
200	14.9	28.2	0.0

Dimensions Inches (mm)

Weight 19 lbs (41.8 kg)

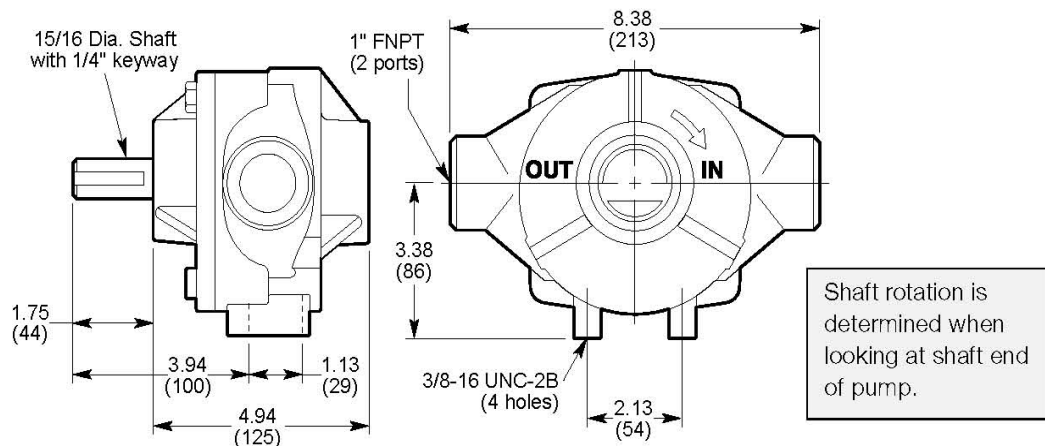

Series 5500 5-Roller Pumps

5500 Cast Iron ♦



5500C Cast Iron pump with CCW rotation
5500C-R Cast Iron pump with CW rotation

5500 Diamond Series™



"Roundup Ready"®

5500D Diamond Series pump with CCW rotation
5500D-R Diamond Series pump with CW rotation

Roundup® is a registered trademark of Monsanto Company

5500 Ni-Resist ♦



5500N Ni-Resist pump with CCW rotation
5500N-R Ni-Resist pump with CW rotation

Shaft rotation is determined when looking at shaft end of pump.

Accessories:

See the accessories section for a complete listing

Torque Bar and Chain



Part #: 39680

Required to anchor PTO-mounted pumps in order to keep pump from rotating with the shaft

Couplers



Part #: 39735

For 1-3/8" diameter PTO; 15/16" pump shaft; 540 RPM; forged steel body, nylon collar*



Part #: 39979

For 1-3/8" diameter PTO; 15/16" pump shaft; 1000 RPM; forged steel body, nylon collar*



Part #: 39992

For 1-3/4" diameter PTO; 15/16" pump shaft; 1000 RPM; forged steel body, nylon collar*

*Nylon collar hardware included

Spray Tech part numbers for Delavan pumps and parts should have the prefix "DE" in front of the listed Delavan numbers.

♦Delavan Cast and Ni-Resist pumps and parts are not standard stock items - special order item.

Roller Pump 6600

Series

- Models:** **6600C** ◇ **Side Ports, Cast Iron (blue finish)**
6600N ◇ **Side Ports, Ni-Resist (brown finish)**
6600D **Side Ports, Diamond™ Series (silver finish)**

Universal Repair Kit

66-6500 RK

6-Roller Pump Repair Kit

Part #	Description	Qty/Kit
19341	Roller, Ultra, 11/16" diameter	6
20468	Universal Lip Seal, Viton	2
50047	Lip Seal, Viton	2
31350-238	Universal Seal Ring	1
24819	Seal Ring	1

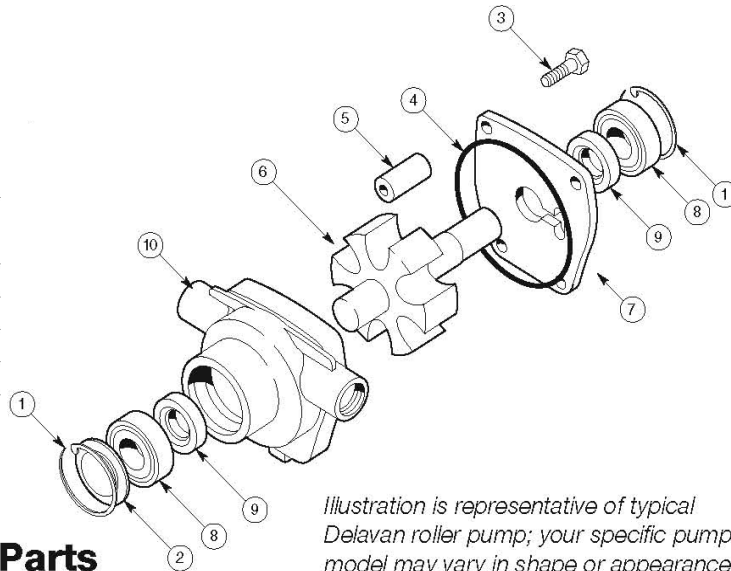

Illustration is representative of typical Delavan roller pump; your specific pump model may vary in shape or appearance.

6600 Series Pump Parts

Ref #	Qty/ Pump	Part #	Description
1	2	15070	Snap Ring
2	1	46210-2	Nameplate 6600C
		46210-7	Nameplate 6600N
		46210-3	Nameplate 6600D
3	4	15077	Cap Screw
4	1	24819	Seal Ring
5	6	19341	Ultra Rollers 11/16"
		19342	Polypropylene Rollers 11/16"
6	1	32601	Shaft & Rotor (Cast Iron/Ni-Resist)
		32603	Shaft & Rotor (Diamond)
7	1	34601	End Plate (Cast Iron)
		31664-2	End Plate (Ni-Resist)
		31664-3	End Plate (Diamond)
8	2	15072	Bearing (STD#6203ZZ)
9	2	50047	Lip Seal, Viton
10	1	33601	Pump Body (Cast Iron, Side Ports)
		50073-2	Pump Body (Ni-Resist, Side Ports)
		50073-3	Pump Body (Diamond, Side Ports)

Spray Tech part numbers for Delavan pumps and parts should have the prefix "DE" in front of the listed Delavan numbers.

◇ Delavan Cast and Ni-Resist pumps and parts are not standard stock items - special order item.

6600

Series 6-Roller Pumps

Max Flow: 19.6 GPM (74.5 LPM)

Max Operating Speed: 1000 RPM

Specifications

Pump

- Type:** 6-roller design
- Max Pressure:** 300 PSIG (21 bar)
- Max Recommended Temperature:** 140°F (60°C)
- Port Size:** 3/4" NPT (female)
- 6600:** Side ports

Mounting:

- Base Mounted:** 5/16-18 UNC-2B (2 holes)
- PTO:** Use torque bar and chain (see accessories)

Shaft

- Size:** 5/8" solid shaft
- Rotation:** CCW (standard); CW (optional).
- (Shaft rotation is determined when looking at shaft end of pump)

Materials of Construction

- Housing:** Cast Iron, Ni-Resist or DiamondSeries™
- Rollers:** 11/16" Ultra rollers (standard); Polypropylene (optional)
- Shaft Seals:** Viton cartridge type lip seals
- Seal Ring:** Viton
- Shaft & Rotor:**
 - Cast Iron & Ni-Resist: Extra-fine finish 404 SST
 - DiamondSeries™: Extra-fine finish 416 SST
- Bearings:** Permanently-lubricated, heavy-duty sealed bearings

Performance

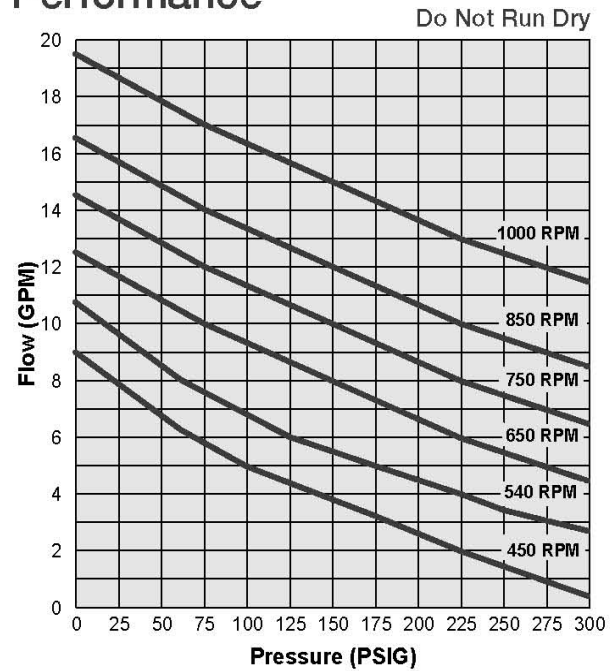

Flow (GPM) @ Specified Pressure and Speed

PSI	540 RPM	1000 RPM	1200 RPM
0	10.5	19.6	22.8
20	9.7	19.0	22.0
40	8.6	18.4	21.3
100	6.9	16.3	19.7
200	4.8	13.9	17.9
300	3.0	11.5	15.8

Dimensions Inches (mm)

Weight 9 lbs (19.8 kg)

6600 Models (side ports)

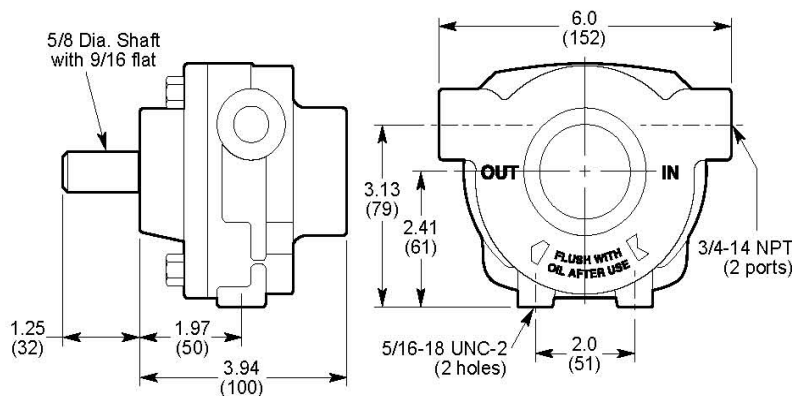

Shaft rotation is determined when looking at shaft end of pump.

Series 6600

6-Roller Pumps

6600 Cast Iron ♦



6600 C Cast iron pump with CCW rotation
6600 C-R Cast iron pump with CW rotation

6600 Diamond Series™



"Roundup Ready"®

6600 D Diamond Series pump with CCW rotation
6600 D-R Diamond Series pump with CW rotation

Roundup® is a registered trademark of Monsanto Company

6600 Ni-Resist ♦



6600 N Ni-Resist pump with CCW rotation
6600 N-R Ni-Resist pump with CW rotation

Accessories:

See the accessories section for a complete listing

Torque Bar and Chain Part #: 33680



Required to anchor PTO-mounted pumps in order to keep pump from rotating with the shaft

Coupler



Part #: 46814-1

For 1-3/8" diameter PTO; 5/8" pump shaft; dual speed 540-1000 RPM; corrosion-resistant cast aluminum, nylon collar; mounting hardware included

Spray Tech part numbers for Delavan pumps and parts should have the prefix "DE" in front of the listed Delavan numbers.

♦Delavan Cast and Ni-Resist pumps and parts are not standard stock items - special order item.

Roller Pump 7000 Series

7-Roller Side Port Roller Pumps

- Models:** 7000C ◇ Cast Iron (blue finish)
 7000N ◇ Ni-Resist (brown finish)
 7000D Diamond™ Series (silver finish)

Universal Repair Kit

70-7700 RK

7-Roller Pump Repair Kit for 7000 Series Pumps

Part #	Description	Qty/Kit
19341	Roller, Ultra, 11/16" diameter	7
47927	Lip Seal, Viton	2
31350-155	Universal Seal Ring	1
24829	Seal Ring	1

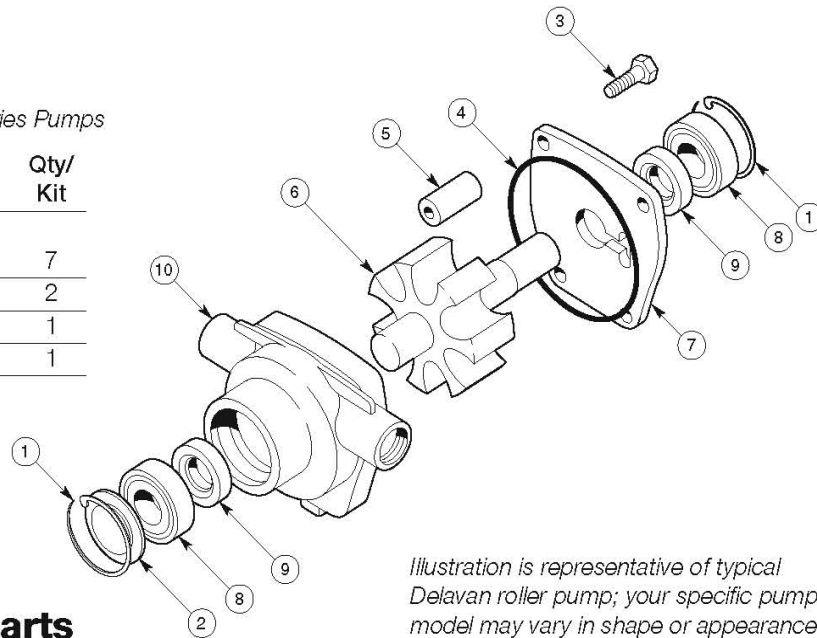

Illustration is representative of typical Delavan roller pump; your specific pump model may vary in shape or appearance.

7000 Series Pump Parts

Ref #	Qty/ Pump	Part #	Description
1	2	15334	Snap Ring
2	1	46209-3	Nameplate 7000C
		46209-4	Nameplate 7000N
		46209-7	Nameplate 7000D
3	4	15341	Cap Screw
4	1	24829	Seal Ring
5	7	19341	Ultra Rollers 11/16"
		19342	Polypropylene Rollers 11/16"
6	1	32702	Shaft & Rotor (Cast Iron/Ni-Resist)
		32705	Shaft & Rotor (Diamond)
7	1	34701	End Plate (Cast Iron)
		31666-2	End Plate (Ni-Resist)
		31666-5	End Plate (Diamond)
8	2	16228	Bearing (STD#6205ZZ)
9	2	47927	Lip Seal, Viton
10	1	33701	Pump Body (Cast Iron)
		24842-2	Pump Body (Ni-Resist)
		24842-5	Pump Body (Diamond)

Spray Tech part numbers for Delavan pumps and parts should have the prefix "DE" in front of the listed Delavan numbers.

◇ Delavan Cast and Ni-Resist pumps and parts are not standard stock items - special order item.

Series 7000 7-Roller Pumps

Max Flow: 22.5 GPM (85.5 LPM)

Max Operating Speed: 850 RPM

Specifications

Pump

Type: 7-roller design

Max Pressure: 200 PSIG (14 bar)

Max Recommended Temperature: 140°F (60°C)

Port Size: 3/4" NPT (female)

Mounting:

Base Mounted: 3/8-18 UNC-2B (2 holes)

PTO: Use torque bar and chain (see accessories)

Shaft

Size: 15/16" solid shaft

Rotation: CCW (standard); CW (optional)

(Shaft rotation is determined when looking at shaft end of pump)

Materials of Construction

Housing: Cast Iron, Ni-Resist or Diamond Series™

Rollers: 11/16" Ultra rollers (standard);

Polypropylene (optional)

Shaft Seals: Viton cartridge type lip seals

Seal Ring: Viton

Shaft & Rotor:

Cast Iron & Ni-Resist: Extra-fine finish 404 SST

Diamond Series™: Extra-fine finish 416 SST

Bearings: Permanently-lubricated, heavy-duty sealed bearings

Performance

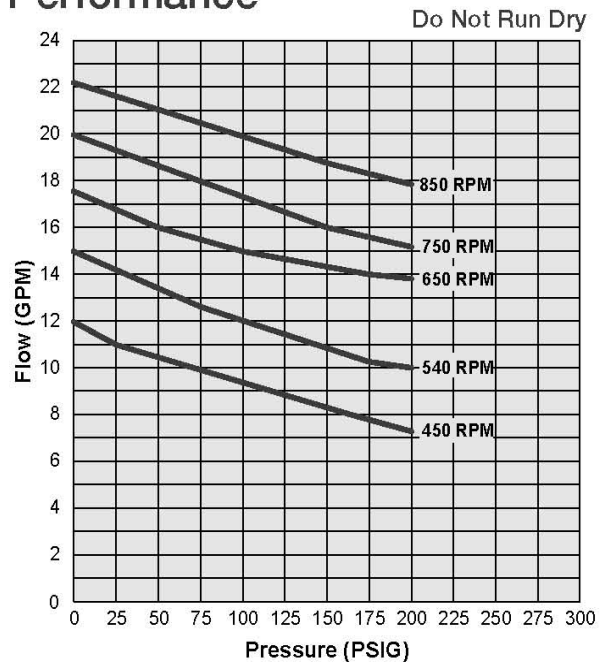

Flow (GPM) @ Specified Pressure and Speed

PSI	540 RPM	650 RPM	850 RPM
0	15.2	17.7	22.5
20	14.5	17.0	21.8
40	13.6	16.2	21.0
100	12.0	15.0	20.0
200	10.0	13.9	18.0

Dimensions Inches (mm)

Weight 14 lbs (30.8 kg)

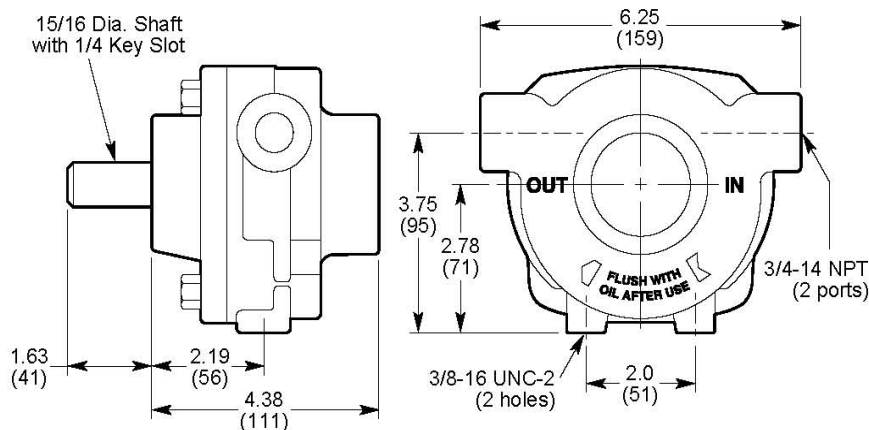

Series 7000 7-Roller Pumps

7000 Cast Iron ♦



7000C Cast Iron pump with CCW rotation
7000C-R Cast Iron pump with CW rotation

7000 Diamond Series™



"Roundup Ready"®

7000D Diamond Series pump with CCW rotation
7000D-R Diamond Series pump with CW rotation

7000 Ni-Resist ♦



7000N Ni-Resist pump with CCW rotation
7000N-R Ni-Resist pump with CW rotation

Roundup® is a registered trademark of Monsanto Company

Accessories:

See the accessories section for a complete listing

Torque Bar and Chain

Part #: 93680

Required to anchor PTO-mounted pumps in order to keep pump from rotating with the shaft



Couplers

Part #: 46814-3

For 1-3/8" diameter PTO, 15/16" pump shaft; dual speed 540-1000 RPM; corrosion-resistant cast aluminum, nylon collar*



Part #: 95735

For 1-3/8" diameter PTO; 15/16" pump shaft; 540 RPM; forged steel body, nylon collar*



*Mounting hardware included

Shaft rotation is determined when looking at shaft end of pump.

Spray Tech part numbers for Delavan pumps and parts should have the prefix "DE" in front of the listed Delavan numbers.

♦Delavan Cast and Ni-Resist pumps and parts are not standard stock items - special order item.

Roller Pump 8800 Series

8-Roller Side Port Roller Pumps

- Models:** 8800C ◇ Cast Iron (blue finish)
 8800N ◇ Ni-Resist (brown finish)
 8800D Diamond™ Series (silver finish)

Universal Repair Kit

88-7560 RK

8-Roller Pump Repair Kit for 8800 Series Pumps

Part #	Description	Qty/Kit
19341	Roller, Ultra, 11/16" diameter	8
47927	Lip Seal, Viton	2
31350-155	Universal Seal Ring	1
24829	Seal Ring	1

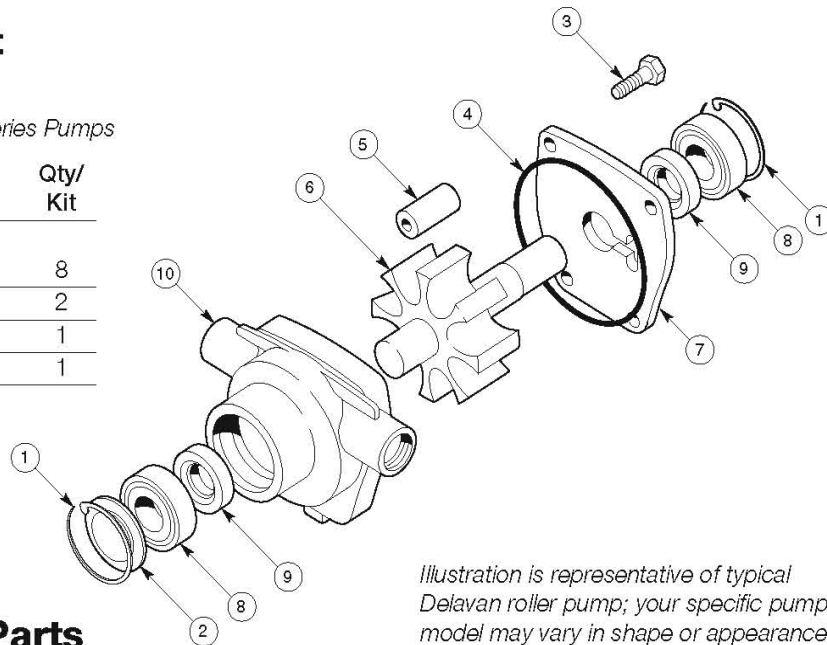

Illustration is representative of typical Delavan roller pump; your specific pump model may vary in shape or appearance.

8800 Series Pump Parts

Ref #	Qty/ Pump	Part #	Description
1	2	15334	Snap Ring
2	1	46209-1	Nameplate 8800C
		46209-2	Nameplate 8800N
		46209-6	Nameplate 8800D
3	4	15341	Cap Screw
4	1	24829	Seal Ring
5	8	19341	Ultra Rollers 11/16"
		19342	Polypropylene Rollers 11/16"
6	1	32802	Shaft & Rotor (Cast Iron/Ni-Resist)
		32805	Shaft & Rotor (Diamond)
7	1	34801	End Plate (Cast Iron)
		31666-4	End Plate (Ni-Resist)
		31666-6	End Plate (Diamond)
8	2	16228	Bearing (STD#6205ZZ)
9	2	47927	Lip Seal, Viton
10	1	33801	Pump Body (Cast Iron)
		24842-4	Pump Body (Ni-Resist)
		24842-6	Pump Body (Diamond)

Spray Tech part numbers for Delavan pumps and parts should have the prefix "DE" in front of the listed Delavan numbers.

◇ Delavan Cast and Ni-Resist pumps and parts are not standard stock items - special order item.

Series 8800 8-Roller Pumps

Max Flow: 24 GPM (91.2 LPM)

Max Operating Speed: 1000 RPM

Specifications

Pump

Type: 8-roller design
Max Pressure: 300 PSIG (21 bar)
Max Recommended Temperature: 140°F (60°C)
Port Size: 3/4" NPT (female)

Mounting:

Base Mounted: 3/8-18 UNC-2B (2 holes)
PTO: Use torque bar and chain (see accessories)

Shaft

Size: 15/16" solid shaft
Rotation: CCW (standard); CW (optional)
 (Shaft rotation is determined when looking at shaft end of pump)

Materials of Construction

Housing: Cast Iron, Ni-Resist or DiamondSeries™

Rollers: 11/16" Ultra rollers (standard);
 Polypropylene (optional)

Shaft Seals: Viton cartridge type lip seals

Seal Ring: Viton

Shaft & Rotor:

Cast Iron & Ni-Resist: Extra-fine finish 404 SST
 DiamondSeries™: Extra-fine finish 416 SST

Bearings: Permanently-lubricated, heavy-duty sealed bearings

Performance

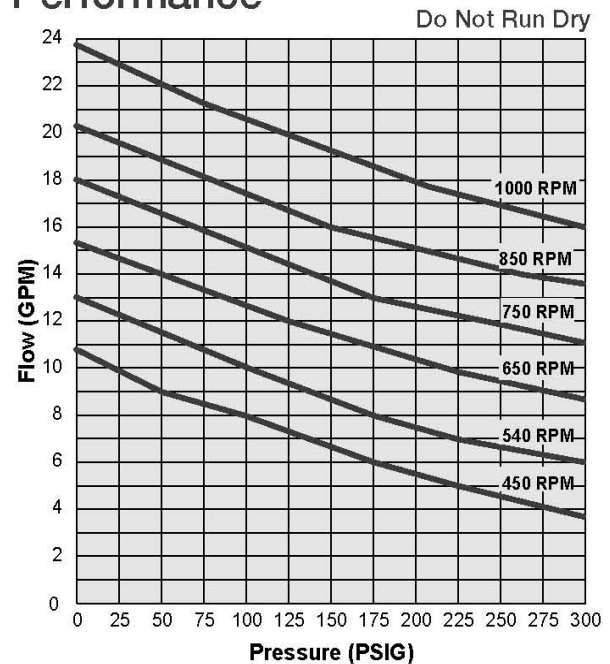

Flow (GPM) @ Specified Pressure and Speed

PSI	540 RPM	850 RPM	1000 RPM
0	13.0	20.2	24.0
20	12.4	19.8	23.2
40	11.6	19.1	22.4
100	10.6	18.6	21.8
200	8.9	15.7	18.0
300	7.0	14.0	17.1

Dimensions Inches (mm)

Weight 14 lbs (30.8 kg)

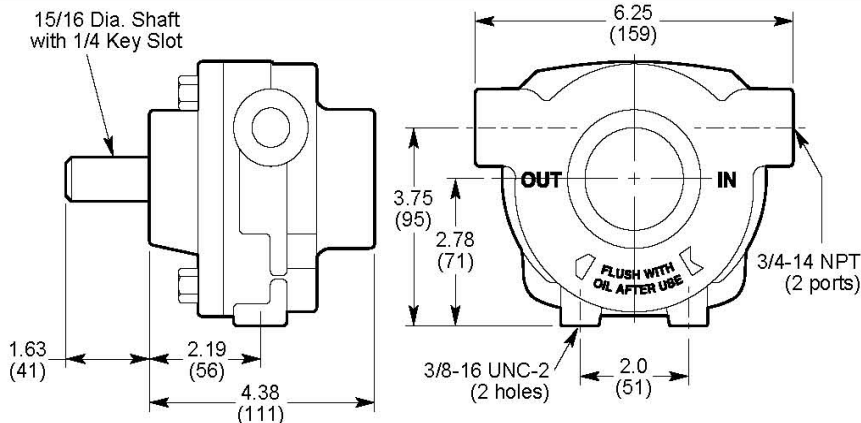

Shaft rotation is determined when looking at shaft end of pump.

Series 8800 8-Roller Pumps

8800 Cast Iron ♦



8800C Cast Iron pump with CCW rotation
 8800C-R Cast Iron pump with CW rotation
 88680C-3 Cast Iron pump with CCW rotation,

8800 Diamond Series™



"Roundup Ready"®

8800D Diamond Series pump with CCW rotation
 8800D-R Diamond Series pump with CW rotation

Roundup® is a registered trademark of Monsanto Company

8800 Ni-Resist ♦



8800N Ni-Resist pump with CCW rotation
 8800N-R Ni-Resist pump with CW rotation

Shaft rotation is determined when looking at shaft end of pump.

Accessories:

See the accessories section for a complete listing

Torque Bar and Chain



Part #: 39680

Required to anchor PTO-mounted pumps in order to keep pump from rotating with the shaft

Couplers



Part #: 46814-3

For 1-3/8" diameter PTO; 15/16" pump shaft; dual speed 540-1000 RPM; corrosion-resistant cast aluminum, nylon collar*



Part #: 36795

For 1-3/8" diameter PTO; 15/16" pump shaft; 540 RPM; forged steel body, nylon collar*



Part #: 36979

For 1-3/8" diameter PTO; 15/16" pump shaft; 1000 RPM; forged steel body, nylon collar*



Part #: 36992

For 1-3/4" diameter PTO; 15/16" pump shaft; 1000 RPM; forged steel body, nylon collar*

*Missing hardware included

Spray Tech part numbers for Delavan pumps and parts should have the prefix "DE" in front of the listed Delavan numbers.

♦Delavan Cast and Ni-Resist pumps and parts are not standard stock items - special order item.

Turbo 90™ Pump



Features:

The **Turbo™ 90** is designed to operate directly from a 1000 RPM PTO shaft without attachments. Peak performance at slower rotation means longer life of the seals. The Turbo 90 can pump suspended materials without accumulation unlike a conventional turbine pump. This is possible because of **Pressure Relief Passages** from the seal cavities to the inlet port. The suspension circulates, and therefore is cleaned from the inner cavities. It can be used for large quantity liquid transfer, from truck to tanks, for instance. It is well suited to high volume sprayer pumping applications.

The **impeller** is made of low moisture absorption, corrosion-resist, engineering grade thermoplastic. It has been designed to increase pump life and smooth operation because of less rotation weight.

Seals available are either face seals or lip seals. Specify face seals for severe service (such as abrasives). Face seals feature hard, wear-resistant phenolic rings pressing against ceramic seats.

Bearings are isolated by drain cavities. **1 1/2" inlet and outlet ports** permit unrestricted high volume flow. Because of the high capacity of the Turbo 90, sufficient bypass flow is available to maintain maximum agitation. **Shaft** is made of stainless steel and has a 15/16" diameter with 1/4" keyway.

Turbo™ 90 Flow Rates — Gallons per minute

PUMP SPEED (RPM)	GALLONS PER MINUTE (GPM) AT POUNDS PER SQUARE INCH AT THE GAUGE (PSIG)										
	0	10	20	30	40	50	60	70	80	90	100
600	45	30	19	8	—	—	—	—	—	—	—
800	60	47	37	27	19	11	3	—	—	—	—
1000	75	65	55	46	37	30	24	18	12	6	—
1200	90	80	73	65	57	49	42	36	31	25	20

Severe Service model: A Turbo 90 pump is available with a **stainless steel impeller** and long life **face seals** for severe service. The stainless steel impeller will not swell or absorb chemicals because of its steel construction; is tough, durable and virtually indestructible; and is corrosion resistant.

Caution: Failure to use a suction strainer, as specified, may void the product warranty.

Note: A high capacity strainer with a 20-mesh screen must be used on the inlet side.

Note: A 1000 RPM PTO coupler must be used. The capacity or flow of the Turbo 90 pump used with a 540 RPM PTO coupler is about zero.

1000 RPM Quick Couplers: Quick couplers provide quick and simple on-off installation. The body is steel and the collar is Super Tough Nylon, color-coded International Orange for 35979, 1 3/8" PTO Coupler, and International Yellow for 35992, 1 3/4" PTO Coupler, according to safety standards.

Collar Coupler: This coupler reduces the chances of vibration because it clamps a full 360° on a 15/16" pump shaft, and on either 1 3/8" or 1 3/4" tractor PTO, like a collet. This provides better centering of the pump shaft to the tractor PTO. Both ends of the coupler must be wrench tightened onto the PTO shaft and the pump shaft prior to operation.

Note: Do not force coupler onto the PTO spline too far. 1/4" to 3/8" of PTO spline should be visible after coupler is in position.

Torque Bar and Chain: This part is needed to anchor a pump mounted directly on a PTO to keep it from turning with the PTO shaft.

Turbo 90 Repair Kits: 28455-1 repair kit for 26556-11 cast iron pump with face seals includes one gasket, two seal rings, for O-rings, two ceramic seats, two seat rings, two springs, and two seal supports. P/N 28455-2 repair kit for 26556-4 cast iron pump with lip seals includes one gasket and two lip seals.

Warning: When using PTO-driven equipment, leave shields in place. Do not wear loose-fitting clothing near rotating PTO shafts.

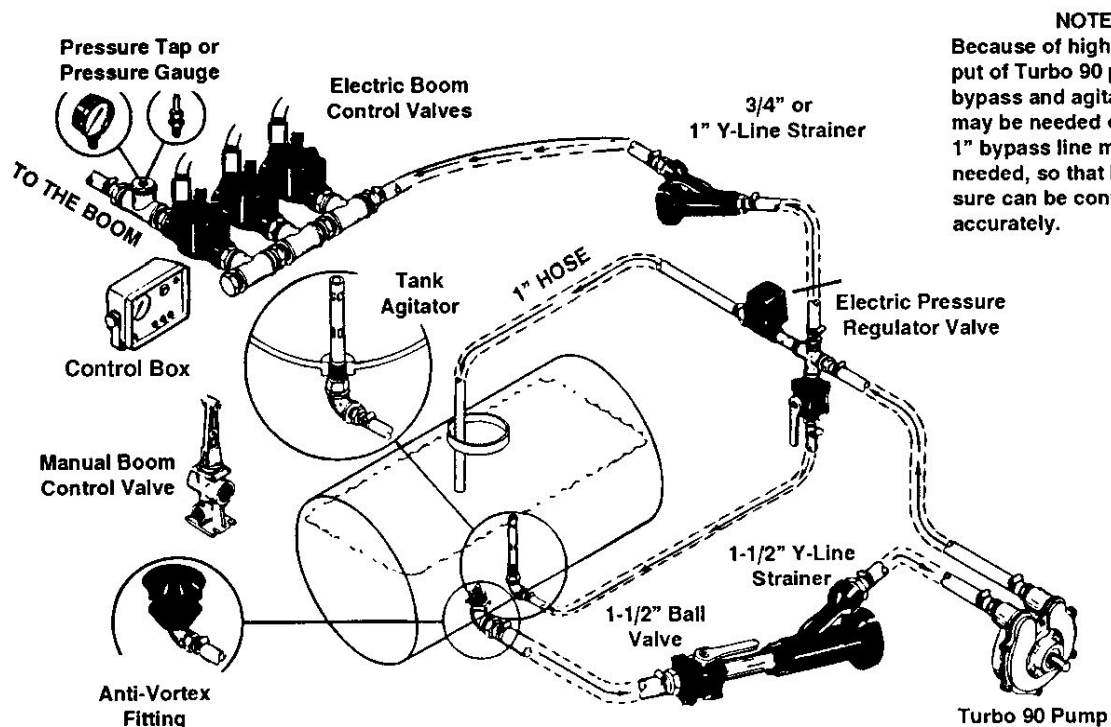

Figure 1. Plumbing for Pump Installation

Pump Installation

1. When using a quick coupler, line up key in the quick coupler with keyway on pump shaft and slide coupler into place, also lining up other set screw with spot on shaft. Tighten the set screw over the spot on the shaft first, then the keyway set screw.
2. When using quick couplers, pull collar back and slide onto the PTO shaft until it locks into place, release collar.
3. When using a Collar Coupler, slide onto pump shaft, then PTO shaft, leaving 1/4" to 3/8" of PTO spline visible. Tighten both ends of the coupler with a wrench.
4. Position pump below liquid level in tank to assure priming.
5. On other than PTO installations, check pump rotation. An arrow on the pump shows direction of rotation.
6. To keep pump from rotating with PTO shaft, use a torque bar and chain assembly 33680 (Fig. 3). Bolt bar to pump, using two adjacent flange bolts. Snap one end of chain to the torque bar and the other end to a stationary part of the tractor. Mount the torque bar so the counter force will raise up on the pump and help relieve the side pressure due to weight of the pump

and hose. Do not fasten pump rigidly to the tractor.

7. With the pump in position, connect the inlet hose to the IN port. Use a 1 1/2" I.D. hose if you need maximum flow rates (Fig. 1).

Note: Support hoses where necessary to keep weight off the pump.

Caution: Failure to use a suction strainer, as specified, may void the product warranty.

8. A high capacity strainer with a 20-mesh screen must be used on the inlet side (Fig. 1).
9. For in-line protection of nozzles, use a 40-mesh strainer in the boom feed line. Use a 3/4" or 1" Y-type strainer (Fig. 1).
10. To regulate pressure, install either a 1 1/4" ball valve or 1" pressure regulating valve downstream from the pump discharge (Fig. 1). Do not use a spring-loaded valve.
11. Check all hose connections. Loose connections can permit air to be drawn in and the pump may not prime properly.

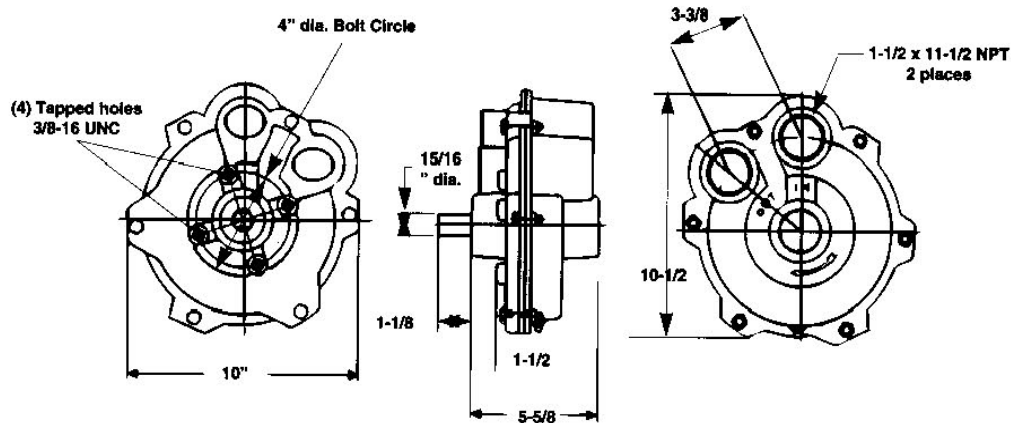

Figure 2. Dimensions

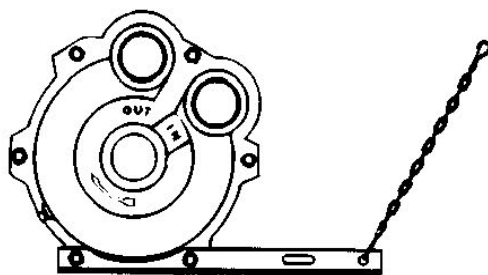

Figure 3. Torque bar and chain assembly, installed

Pump Operation

1. Before starting, make sure all air is removed from pump and lines.
2. Do not use rusty supply barrels or sandy water.

Caution: Running pump dry can cause excessive heat and damage seals.

3. Do not start pump before priming. The pump is NOT self-priming. Be sure suction line and pump are filled with liquid. Open the pressure regulating and boom regulating valves to be sure there is no back pressure on pump. Do not close the discharge line of the pump unless a means of bypassing the liquid relief valve has been installed. Pump can then be started and should prime. To assure ease in prime and the bleeding of air in pumping system, install pump so that ports are upright.

Caution: Operating above maximum limits can damage pump.

4. Do not operate pump at a PTO speed in excess of 1250 RPM, or a pressure higher than 100 psi (7 bars), or a temperature higher than 120° F (50° C).

Pump Maintenance

1. Bearings require no lubrication.
2. Drain. If pump remains installed on tractor, remove drain plug to drain pump. If pump has been removed from tractor, use IN and OUT ports for draining.
3. Flush. After use, thoroughly flush pump with clear water. If available, use a solution of one cup of ammonia in 10 gallons of water. This will dissolve most residue remaining in the pump. Drain, let dry, then flush pump with light lubricating oil.
4. Store.

Caution: Gasoline, kerosene or fuel oil can attack materials in pump. Do not use as storing solution.

If pump is to be stored, follow flush with a 50 percent permanent antifreeze solution. Plug ports.

**MAXIMUM RECOMMENDED PRESSURE:
100 PSIG (7 BARS)**

**MAXIMUM RECOMMENDED TEMPERATURE:
120° F (50° C)**

**MAXIMUM RECOMMENDED PTO SPEED:
1250 RPM**

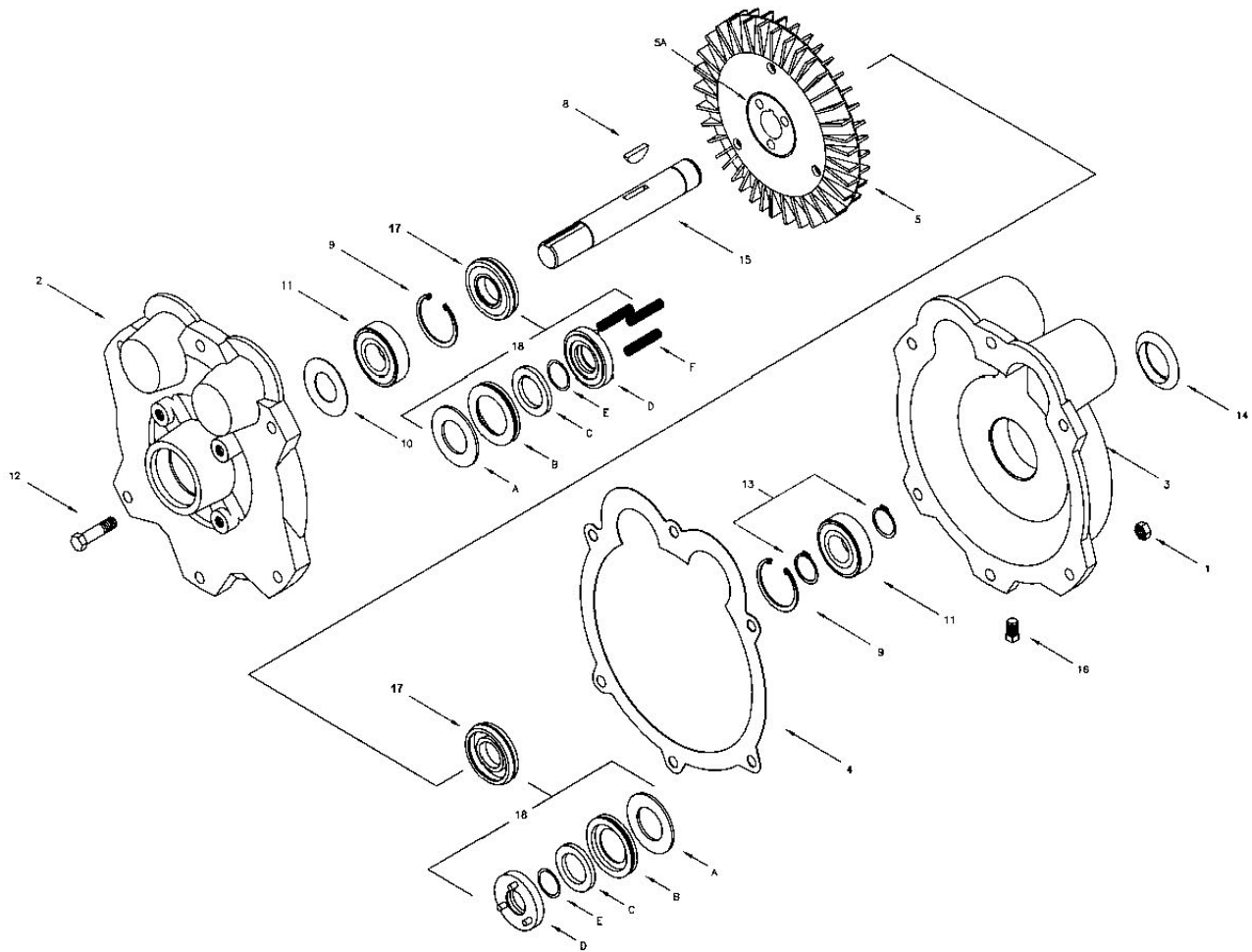

Figure 5. Turbo™ 90 Exploded View

Note: Turbo 90 pumps, P/N 26556-11 and 26556-14 are equipped with face seals. These seals are six-piece assemblies, P/N 50914. Replace worn face seals with P/N 50914. Be sure Wave Spring side is toward impeller (5).

Note: Turbo 90 pump P/N 26556-4 is equipped with lip seals. These seals are two-piece assemblies which include a seal and a seal adapter in each.

If your pump is equipped with two-piece seal assemblies, use P/N 45005 (Turbo 90 Lip Seal) as the replacement seal. This seal is about 1 3/4" in diameter.

If the seal adapter has been damaged, use P/N 45006 as the replacement adapter. When replacing seal, be sure spring side faces liquid flow.

Turbo™ 90 Pump and Accessories Parts List

REF. NO	PART NO.	DESCRIPTION	QUANTITY REQUIRED 26556-
			4
	26556-4	Cast Iron T-90 Pump Assembly with lip seals and thermoplastic impeller	
1	17902	Hex Nut (3/8"-16 UNC)	6
2	39923-1	End Plate, Cast Iron	1
3	39924-1	Body, Cast Iron	1
4	26545	Gasket	1
5	28709	Impeller, Thermoplastic	1
	50019	Impeller, Stainless Steel	—
5a	30512	Hub	1
8	26544	Woodruff Key	1
9	26548	Snap ring, Internal	2
10	26665	Dust Shield	1
11	16228	Bearing, Shielded	2
12	39934	Cap Screw, Hex Head (3/8"-16 UNCx1 5/8")	6
13	26547	Snap ring, External	2
14	39935	Nameplate	1
15	34793	Shaft	1
16	25785	Pipe Plug, Square Head	1
17	45005	Lip Seal Assembly - Includes Lip Seal and Adapter	2
18	50914	Face Seal Assembly	—
A	31352-225	Washer	
B	51210	Ceramic Seat	
C	51211	Seal Ring	
D	31352-214	O-Ring	
E	51212	O-Ring	
F	51213	Wave Spring	
Repair Kits	33680	Torque Bar and Chain Assembly	—
	28455-1 ¹	Repair Kit for 26556-11, -12, and -14 pumps with Face Seals (includes one P/N 26545, gasket, and two P/N 50914, Face Seals)	—
	28455-2 ¹	Repair Kit for 26556-4, -10 with Lip Seals (includes one P/N 26545, gasket and two P/N 45005 lip seal assemblies)	—

¹Both repair kits may be used in all Turbo 90 pumps.

Spray Tech part numbers for Delavan pumps and parts should have the prefix "DE" in front of the listed Delavan numbers.

The numbers in parentheses are reference numbers that are found in the exploded view on page 4. Underlined parts are included in repair kits, and can be discarded if using kit.

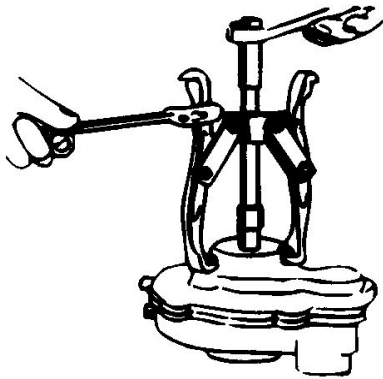

Figure 6. Pulling end plate from body

Pump Disassembly

1. If coupler is on pump shaft, remove.
2. With a 9/16" wrench, unscrew 6 nuts (1) from capscrews (12) and remove capscrews.
3. Screw two screws (12) into opposite threaded holes on end plate (2). Install puller (Fig. 6). Tighten puller with a wrench to pull end plate (2) from body (3). Lift off end plate (2).

Note: Although a puller is recommended, you can separate the end plate (2) from the body (3) by using a 1" diameter brass rod at the shaft end, tapping it with a hammer.

4. Remove gasket (4).

Note: Snap rings (9,13) bearings (11) and shaft (15) should not be removed unless damage has occurred.

5. Use snap ring pliers to remove snap ring (9) from end plate (2).
6. To remove bearing (11), push out with arbor press or use a small piece of brass rod and gently tap with hammer.
7. Remove dust shield (10).
8. Use snap ring pliers to remove snap ring (9) from body (3).
9. Using screwdriver, pry nameplate (14) from body (3).
10. Push shaft (15) and bearing (11) out of body (3) with an arbor press or by using a small piece of brass rod and tapping with hammer.
11. Remove snap rings (13) from shaft (15).
12. Press bearing (11) from shaft (15).
13. **P/N 26556-11, -12, and -14 pump with face seals (skip to next section if your pump has lip seals):**
 - a. Pry out ceramic seat (B) and seal ring (C) from end plate (2).
 - b. Lift out dust shield (10) from end plate.
 - c. Slide seal ring (C) with O-ring from shaft.
 - d. Lift out three springs (F) from impeller (5).
 - e. Lift impeller (5) from body (3).
 - f. Remove Woodruff key (8) from shaft.
 - g. Slide other seal ring (C) with O-ring from shaft.

- h. Pry out ceramic seat (B) and seal ring (C) from body (3).
- i. Remove dust shield (10) from body.

14. P/N 26556-4 and -10 pump with lip seals (return to previous section if your pump has face seals):

- a. Lift impeller (5) from body (3).
- b. Remove Woodruff key (8) from shaft (15).
- c. Using screwdriver, pry nameplate (14) from body (3).
- d. Remove snap ring (13) from pump shaft.
- e. Push the pump shaft out using an arbor press or a small brass rod by gently tapping with a hammer.
- f. Using a drift punch, from the painted side of each casting, drive the old lip seal (17) out by hitting on the old seal case. Discard old lip seals.

Pump Assembly

Preparation

1. Thoroughly clean all metal parts in solvent with a soft-bristle brush.
2. Coat metal parts with light lubricating oil to assure easier assembly.
3. Obtain repair kit 28455 which contains parts listed on the parts list, page 5. Replace all old parts with new parts from repair kit.

Assembly

1. If bearings (11) were removed, lightly oil bearing cavities.
2. Place dust shield (10) in end plate (2) and, applying pressure to outer bearing race, press bearing (11) downward until it bottoms.
3. Install snap ring (9) in end plate (2).
4. Press other bearing (11) into body (3).
5. Install snap ring (9) in body. Install inner snap ring (13) on shaft (15) and press shaft into bearing (11). Install outer snap ring (13) on end of shaft (15).

6. P/N 26556-11, -12, and -14 pump with face seals (skip to next section if your pump has lip seals):

- a. Place seal support (A) in body (3).
- b. Place the ceramic seat into the pump body all the way down on the O-ring (A).

Note: Ceramic seat (B) is installed with O-ring groove and side with marking toward the outside of the pump.

- c. Lubricate the O-ring groove on the ceramic seat (B) with clean oil or petroleum jelly. Place the ceramic seat into the body. Carefully force the seat down over the O-ring until it is against the seal support.

Caution: The ceramic seat may be cracked or broken if it is placed in the body cocked or if excessive force or metal objects are used to drive it in place.

- d. Slide the new seal ring (C) onto the shaft with the internal O-

- ring groove toward the inside of the pump. The small diameter of seal ring should mate with the ceramic seat.
- e. Slide the small O-ring (D) onto the shaft. Push the O-ring out of the key way to avoid cutting the O-ring. Push the O-ring into the groove in the seal ring.
- f. Slide the small washer (E) over the shaft and into the recess in the seal ring.
- g. Slide the wave spring (F) over the shaft and onto the washer (E). The spring will rest against the impeller hub.
- h. Install the face seal in the end plate (2) in the same way as into the body (3).

6. P/N 26556-4 pump with lip seals (return to previous section if your pump has face seals):

- a. Install lip seals (P/N 45005) using sealant such as Permatex on the mating surfaces. Press to the bottom of the seal bores in both end plate and body. See exploded view, page 4.
- b. Tap lip seal (17) into pump body using pipe nipple or seal driver of a diameter large enough to push on the inside of the concave side of the seal. The cupped, concave side of the seal faces towards the inside of the pump. The spring faces toward the liquid flow.
- c. Make sure the seal bottoms against the seal supporting edge machined into the casting.
- d. Install Woodruff key (8) in shaft (15). Be sure the key bottoms.
- e. Slide impeller (5) onto shaft.

- f. Tap lip seal (17) into end plate adapter (45006) using pipe nipple or seal driver. Cupped or concave side goes toward the inside of pump; spring faces toward liquid flow.
- g. Make sure the seal bottoms against the seal supporting edge machined into the casting.

- 7. Place gasket (4) on body (3).
- 8. With an arbor press, press on inner race and press end plate (2) onto shaft (15).

Caution: Uneven tightening of nuts (1) and cap-screws (12) to pull end plate (2) down can crack casting.

Note: Although an arbor press is recommended, if none is available, you can pull end plate onto body by carefully tightening nuts (1) and capscrews (12).

- 9. Install capscrews (12) and nuts (1) and tighten.
- 10. Turn shaft to be sure the pump is not binding. If pump seems to be binding, tap shaft lightly with a soft hammer.
- 11. Replace nameplate (14) in body (3). Nameplate is merely pushed into place.

Turbo™ 90 Troubleshooting Guide

PROBLEM	CAUSE	PROCEDURE
1. NO PRESSURE, OR NO CAPACITY	<ul style="list-style-type: none"> a. Inlet line not immersed in liquid or low level b. Pump not primed c. Plugged strainer d. Intake line air leaks e. Intake line blocked f. Pump turning wrong direction g. Pump parts worn 	<ul style="list-style-type: none"> a. Reposition inlet line or fill tank. b. Prime pump; be sure mounted below water level. c. Clean strainer with water and soft brush if needed. d. Tighten all connections, using pipe joint compound. Check hoses for leaks. e. Check line and clean. f. Check direction of arrow on pump, mount correctly. g. Replace using Repair Kit, or return for repair or if under warranty.
2. EXCESSIVE NOISE OR VIBRATION	<ul style="list-style-type: none"> a. Loose coupler b. Bent or damaged shaft, improperly aligned c. Intake line leaks; plugged strainer d. Worn parts, broken rotor vanes 	<ul style="list-style-type: none"> a. Tighten or replace coupler. b. Replace shaft. c. See PROCEDURES c. and d. above. d. See PROCEDURE g. above.
3. PUMP RUNS, BUT LOW CAPACITY	<ul style="list-style-type: none"> a. PTO speed too slow. b. Intake line partially blocked or too small c. Too many fittings, elbows, valves d. Plugged strainer or leaks 	<ul style="list-style-type: none"> a. 1000 RPM required. b. Clean line. Use 1 1/2" I.D. hose. c. Replumb for more direct path. d. See PROCEDURES c. and d., block 1.
4. PRESSURE AT PUMP, BUT LOW OUTPUT AT NOZZLES	<ul style="list-style-type: none"> a. Nozzle orifice too small or strainer plugged b. Discharge line too small c. Valves set incorrectly 	<ul style="list-style-type: none"> a. Replace nozzles; clean nozzle strainer. b. Use 1 1/2" I.D. hose. c. Check, adjust valves.
5. IMPOSSIBLE TO ROTATE SHAFT	<ul style="list-style-type: none"> a. Improper assembly b. Foreign material or corrosion in pump 	<ul style="list-style-type: none"> a. Gasket in place? Review assembly instructions. b. Disassemble and clean. Use clean water supply.
6. LEAK	<ul style="list-style-type: none"> a. Lip seal installed backward b. Worn parts c. Worn casting 	<ul style="list-style-type: none"> a. Check drawing page 4. Spring should be toward liquid. b. Repair using repair kit. c. Replace pump.

Repair Kits & Accessories

Turbo 90 Accessories

Turbo 90 Repair Kits



Kit contains appropriate style seals, gasket and instructions.

With Face Seals:
28455-1



With Lip Seals:
28455-2

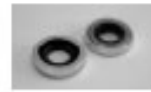

Roller Pump Accessories

Universal Roller Pump Repair Kits



Universal repair kits contain ultra rollers, shaft seals, O-rings and instructions.

4400 Pump44-4000RK
5500 Pump55-1700RK
6500 Pump66-6500RK
7000 Pump70-7700RK
8800 Pump88-7560RK

Quick Couplers (for Turbo-90 and Roller Pumps)

Quick couplers provide quick and simple on-off installation. The body is steel and the collar is durable nylon. 12 that is color-coded according to international safety standards.



Description	Part #	Pump Compatible	Shaft Diameter		Max RPM
			Pump	Drive	
Corrosion-resistant cast aluminum body, nylon collar; multi-speed quick coupler	46814-1	6500	5/8"	1-3/8"	540/1000
	46814-2	Old style pumps	7/8"	1-3/8"	540/1000
	46814-3	7000*, 8800	15/16"	1-3/8"	540/1000
<i>Do not use 46814 couplers on 5500 roller pumps or Turbo-90! * Use a 1540 RPM only</i>					
	35735	7000, 8800, 5500	15/16"	1-3/8"	540
	35979	Turbo, 8800, 5500	15/16"	1-3/8"	1000
	35992	Turbo, 8800, 5500	15/16"	1-3/4"	1000

Collar Couplers (for Turbo-90 Pumps)

Collar couplers reduce possible vibration by clamping a full 360° on the pump shaft and PTO. This provides better centering of the pump shaft to the tractor PTO, giving less chance of uneven wear. Both ends of the coupler must be wrench-tightened onto the PTO and pump shafts before operation. Note: Do not force coupler too far onto the PTO. After coupler is in position, 1/4" to 3/8" of PTO should be visible.



Description	Part #	Pump Compatible	Shaft Diameter		Max RPM
			Pump	Drive	
	46935-1	Turbo	15/16"	1-3/8"	1000
	47647	Turbo	15/16"	1-3/4"	1000

Set Screw Coupler (for 4400 Roller Pumps)



Description	Part #	Pump Compatible	Shaft Diameter		Max RPM
			Pump	Drive	
	50101	4400	5/8"	5/8"	2600

Torque Bar and Chain (for Turbo-90 and Roller Pumps)



The Torque Bar and Chain is needed to anchor a PTO-mounted pump to keep it from turning with the PTO shaft. Fits all Turbo-90 and Roller Pumps.
Part Number: 33680

Spray Tech part numbers for Delavan pumps and parts should have the prefix "DE" in front of the listed Delavan numbers.

BANJO PUMPS

1 1/2" & 2" Polypropylene Self-Priming Centrifugal Pumps

6.5 PRO HP MOTOR FEATURES

- Cast Iron Cylinder Sleeve.
- Heavy Duty Flywheel.
- Overhead Valve.
- High Oil Fill
- Oil Guard® Low Oil Sensor.
- Breather Through Air Cleaner.



**200P6PRO
190 GPM**

PUMP FEATURES

- Precision molded construction.
- Corrosion resistant.
- Low maintenance.
- Lightweight.
- Superior design.
- EPDM Standard, FKM (viton type) available.

Maximum Engine Protection!

- We have designed the new Banjo poly pump to protect the engine seal in the event of pump seal failure. We have separated the pump from the engine by 1/2" and installed a special slinger/engine seal that completely protects the engine from any corrosive fluids. This new slinger design is the best in the poly pump industry at protecting your engine.
- For additional seal protection, small vanes are molded into the back side of the impeller. During operation, these vanes (on back side of the impeller) pump out a major portion of the liquid from the seal area which reduces pressure. The internal operating pressure of the pump is approximately 50 P.S.I. with the seal area operating at only 5 P.S.I. This leaves enough liquid in the seal area to lubricate and cool.
- Priming is now made easier by the incorporation of two new prime and drain plugs. These plugs are now made to act as thumb screws with o-ring seals for quick priming and draining before and after use. Priming is from the bottom of the pump chamber. A very small amount of liquid in the bottom of the pump is sufficient for priming since the liquid enters the volute from the bottom side. The pump will prime with the check valve open.
- The impeller has been designed for easy removal during maintenance. A 7/16" — 14 hex nut is installed into the impeller during assembly at our plant. This nut is used to lift the impeller from the engine shaft by screwing a 7/16" — 14 bolt into nut at the end of the impeller.

CAUTION-WARNING: Please do not run pump dry, restrict or reduce port sizes, or dead head pump. This could cause component failure to pump.

DO NOT USE WITH FLAMMABLE LIQUIDS.

NOTE: Engine warranty service available at authorized Briggs & Stratton and Honda dealers.

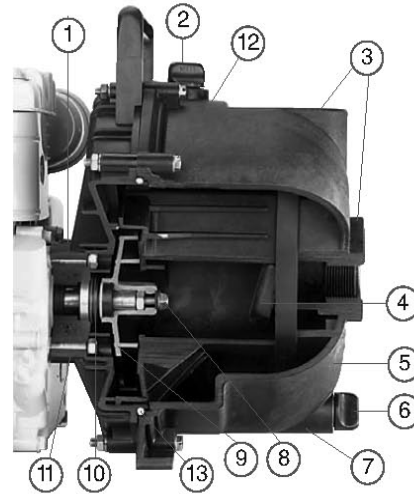

1. Maximum engine protection - pump end is separated from engine
2. Large prime plug thumb screw
3. 1 1/2" & 2" ports
4. Check valve
5. "V" shaped body for quicker priming
6. Large drain plug thumb screw
7. High strength glass-filled polypropylene construction
8. Impeller bolt easily removable
9. High performance precision molded impellers
10. Mechanical shaft seal (available in 3 materials)
11. Large weep holes
12. All stainless steel hardware
13. Heavy duty body O-ring

POLY PUMPS GAS ENGINE PUMPS WITH EPDM RUBBER PARTS (POLY)

PART NO.	DESCRIPTION	HP
150P-3	1 1/2" Pump x 3.5 HP Briggs	3.5
200P-3	2" Pump x 3.5 HP Briggs	3.5
200PH-5	2" Pump x 5.5 HP Honda Engine	5.5
200PH-5E	Complete Pump and 5.5 HP Honda w/Electric Start	5
200P6PRO	Gas Engine Complete Pump & 6.5 HP Briggs Stratton Pro Series Engine	6.5



The Spray Tech part number can be derived by adding the prefix 'TE' to the listed Banjo part numbers.

BANJO PUMPS

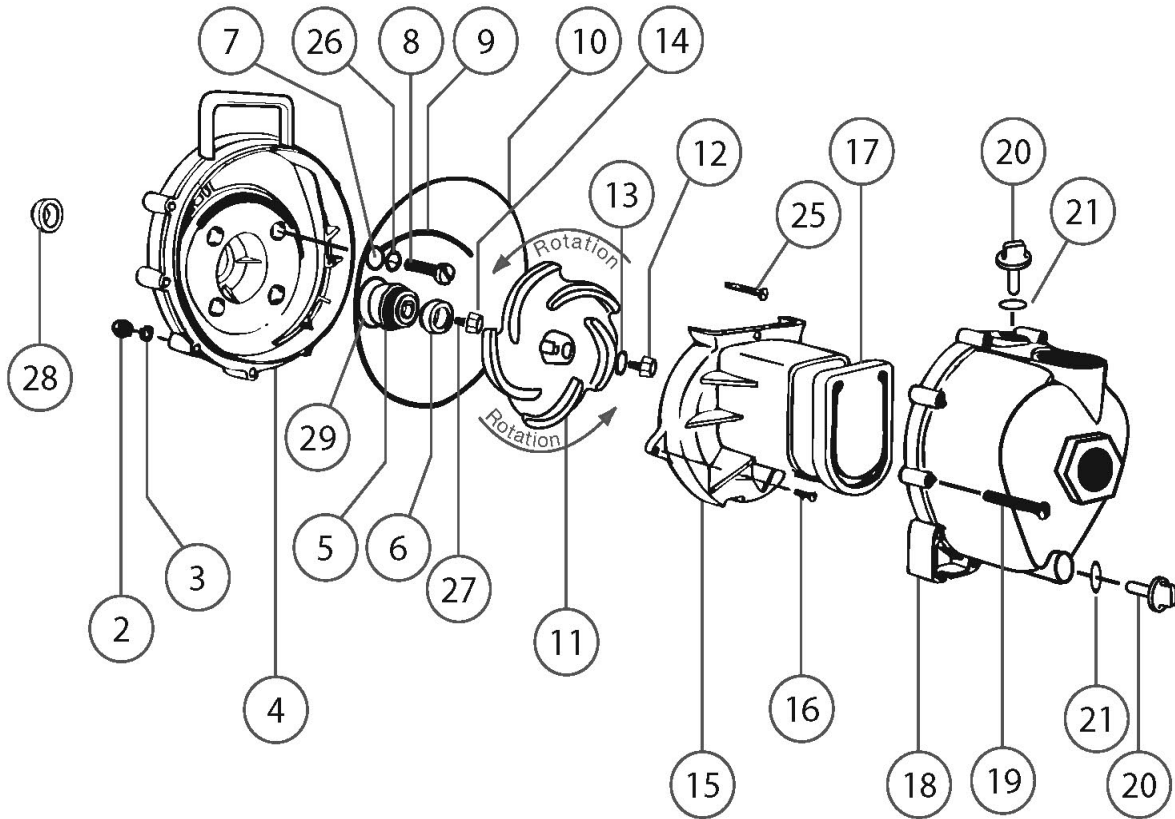

REPLACEMENT PARTS FOR PUMPS MANUFACTURED BEGINNING SEPT. 1996

ITEM	DESCRIPTION	PER PUMP	PART REF.		ITEM	DESCRIPTION	PER PUMP	PART REF.	
			1 1/2"	2"				1 1/2"	2"
2	Body Nuts SS	10	V07019	V07019	18	Poly Pump Body Assembly	1	12711A	12712A
3	Lock Washer SS	10	V07018	V07018	19	Body Screws SS	10	12720	12720
4	Poly Pump Rear Bracket	1	12703A	12703A	20	Prime / Drain Plug	2	12777	12777
5 & 6	Seal Assembly*+	1	12713	12713	21	Prime / Drain Plug O-Ring*	2	UV15163	UV15163
7	Screw Heads "O" Ring*+	4	12717	12717	25	Upper Volute Screw SS	1	12900	12900
8	Bracket Screws SS	4	12715A	12715A	26	Rear Bracket Washer SS	1	12901	12901
9	O-Ring Segment*+	1	12754	12754	27	Impeller Key	1	12902A	12902A
10	Body O-Ring*+	1	12719A	12719A	28	Poly Pump Slinger*+	1	12716	12716
11	3 Vane Poly Pump Impeller+ 3.5 h.p. 5 Vane Poly Pump Impeller+ 5.5 h.p.	1	12771A	12772	29	O-Ring for Seal Assembly*+	1	12710	12710
12	Impeller Bolt SS	1	12785A	12785A	N/S	Complete Bearing Pedestal	1	12882A	12882A
13	Impeller Bolt Gasket*+	1	12774VA	12774VA	N/S	Impeller Removal Bolt	1	12099	12099
14	Impeller Hex Nut	1	12775A	12775A		Pump Repair Kit — 3 Vane Impeller (Consists Of Items Marked With +)	1	12003A	12003A
15	Poly Pump Volute	1	12702A	12702A		Pump Repair Kit — 5 Vane Impeller (Consists Of Items Marked With +)	1	12000A	12000A
16	Volute Screws SS	2	12725	12725		Pump Seal/O-Ring Kit (Consists Of Items Marked with *)	1	12999A	12999A
17	Poly Pump Check Valve+	1	12705	12705					

The Spray Tech part number can be derived by adding the prefix 'TE' to the listed Banjo part numbers.



1 1/2" & 2" Polypropylene Self-Priming Centrifugal Pump Pedestal Pump (for Electric Motors) Pump Only (for Gasoline Engines)



BEARING PEDESTAL PUMPS (FOR ELECTRIC MOTORS)

PART NO.	DESCRIPTION	HP
150PB	1 1/2" Pump/Bearing Pedestal 3/4" Shaft	N/A
200PB	2" Pump/Bearing Pedestal 3/4" Shaft 3 Vane Impeller	N/A
205PB	2" Pump/Bearing Pedestal 3/4" Shaft 5 Vane Impeller	N/A

PUMP ONLY (FOR GASOLINE MOTORS)

PART NO.	DESCRIPTION	HP
150PO	1 1/2" Pump Only - 3/4" shaft, 3 Vane Impeller	N/A
200PO	2" Pump Only - 3/4" shaft, 3 Vane Impeller	N/A
205PO	2" Pump Only - 3/4" shaft, 5 Vane Impeller	N/A

PEDESTAL PUMPS

With the addition of the Banjo bearing pedestal, the pump is easily adaptable to electric power. A flexible shaft coupling is used between motor and pump shaft. Pump and motor assembly is mounted on a metal base.

CAUTION-WARNING: Please do not run pump dry, restrict or reduce port sizes, or dead head pump. This could cause component failure to pump.

DO NOT USE WITH FLAMMABLE LIQUIDS.

POLY PUMPS WITH FKM (viton type) RUBBER PARTS & 316 STAINLESS STEEL SEAL		
PART NO.	DESCRIPTION	QTY.
150P-3-V	1 1/2" Pump - 3.5 h.p. Briggs	1
200P-3-V	2" Pump - 3.5 h.p. Briggs	1
200P6PROV	2" Pump - 6.5 h.p. Briggs Intek	1
200PH-5V	2" Pump - 5.5 h.p. Honda	1
150PB-V	1 1/2" Pump With 3/4" Bearing Pedestal Shaft	1
200PB-V	2" Pump With 3/4" Bearing Pedestal Shaft - 3 Vane Impeller	1
205PB-V	2" Pump With 3/4" Bearing Pedestal Shaft - 5 Vane Impeller	1
150PO-V	1 1/2" Pump Only	1
200PO-V	2" Pump Only - 3 Vane Impeller	1
205PO-V	2" Pump only - 5 Vane Impeller	1

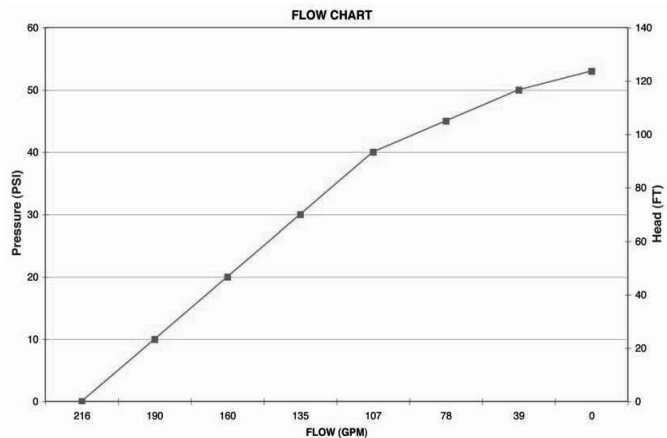

The Spray Tech part number can be derived by adding the prefix 'TE' to the listed Banjo part numbers.

BANJO PUMPS

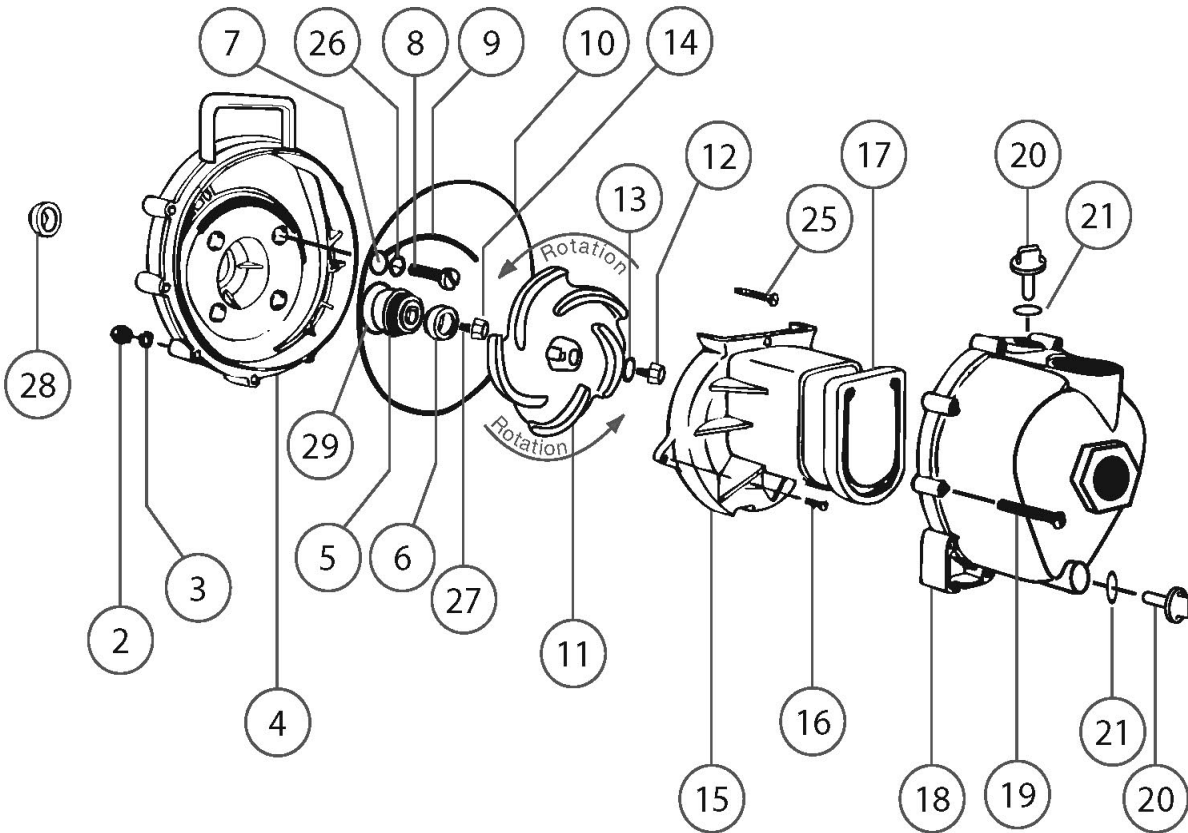

REPLACEMENT PARTS FOR PUMPS MANUFACTURED BEGINNING SEPT. 1996

ITEM	DESCRIPTION	PER PUMP	PART REF.	
			1 1/2"	2"
2	Body Nuts SS	10	V07019	V07019
3	Lock Washer SS	10	V07018	V07018
4	Poly Pump Rear Bracket	1	12703A	12703A
5 & 6	Seal Assembly*+	1	12713	12713
7	Screw Heads "O" Ring*+	4	12717	12717
8	Bracket Screws SS	4	12715A	12715A
9	O-Ring Segment*+	1	12754	12754
10	Body O-Ring*+	1	12719A	12719A
11	3 Vane Poly Pump Impeller+ 3.5 h.p. 5 Vane Poly Pump Impeller+ 5.5 h.p.	1	12771A	12772
12	Impeller Bolt SS	1	12785A	12785A
13	Impeller Bolt Gasket*+	1	12774VA	12774VA
14	Impeller Hex Nut	1	12775A	12775A
15	Poly Pump Volute	1	12702A	12702A
16	Volute Screws SS	2	12725	12725
17	Poly Pump Check Valve+	1	12705	12705
18	Poly Pump Body Assembly	1	12711A	12712A
19	Body Screws SS	10	12720	12720
20	Prime / Drain Plug	2	12777	12777
21	Prime / Drain Plug O-Ring*	2	UV15163	UV15163
25	Upper Volute Screw SS	1	12900	12900
26	Rear Bracket Washer SS	1	12901	12901
27	Impeller Key	1	12902A	12902A
28	Poly Pump Slinger*+	1	12716	12716
29	O-Ring for Seal Assembly*+	1	12710	12710
N/S	Complete Bearing Pedestal	1	12882A	12882A
N/S	Impeller Removal Bolt	1	12099	12099
	Pump Repair Kit — 3 Vane Impeller (Consists Of Items Marked With +)	1	12003A	12003A
	Pump Repair Kit — 5 Vane Impeller (Consists Of Items Marked With +)	1	12000A	12000A
	Pump Seal/O-Ring Kit (Consists Of Items Marked with *)	1	12999A	12999A

The Spray Tech part number can be derived by adding the prefix 'TE' to the listed Banjo part numbers.



2" Polypropylene Chemical Service Pump

FEATURES

1. Additional drive unit protection with added 1" spacer for ultimate protection.
2. Special non-metallic mechanical seal designed for better chemical resistance.
3. All elastomers are FKM (viton type).
4. All internal fasteners are TFE coated stainless steel.
5. The Banjo "Super Slinger" included for even more drive unit protection (not shown).

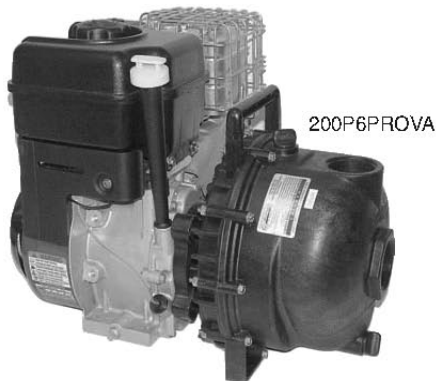
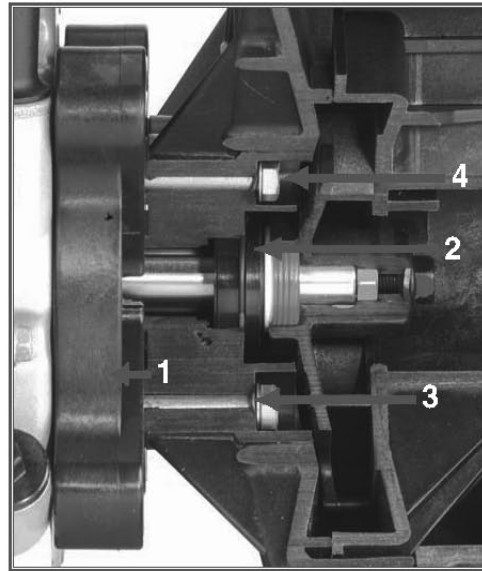

No warranty on chemical service pumps.

POLY PUMPS CHEMICAL SERVICE PUMPS WITH FKM (VITON TYPE) RUBBER PARTS

PART NO.	DESCRIPTION	HP
200P6PROVA	2" X 2" Polypropylene Chemical Service Pump w/ 6.5 HP Briggs & Stratton INTEK PRO Engine	6.5
200PB VA	2" X 2" Polypropylene Chemical Service Pump w/ Bearing Pedestal 3 Vane Impeller	N/A
206PB VA	2" X 2" Polypropylene Chemical Service Pump w/ Bearing Pedestal 5 Vane Impeller	N/A
234PPE5VA	2" X 2" Polypropylene Chemical Service Pump w/ 5.0 HP Three Phase Baldor Electric Motor	5



Poly Pump Engine Spacer Kit -

The 12758 spacer kit includes the poly adapter, adapter shaft, and related hardware to space the pump an additional 1" away from the motor.

NOTE: Advanced installation techniques and pump shimming required with this kit.

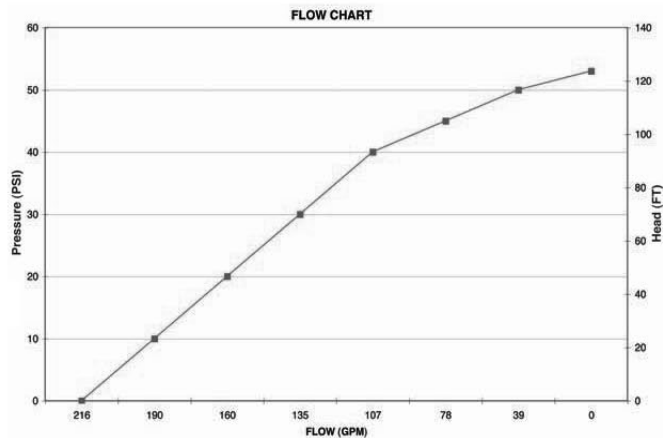

The Spray Tech part number can be derived by adding the prefix 'TE' to the listed Banjo part numbers.

BANJO PUMPS

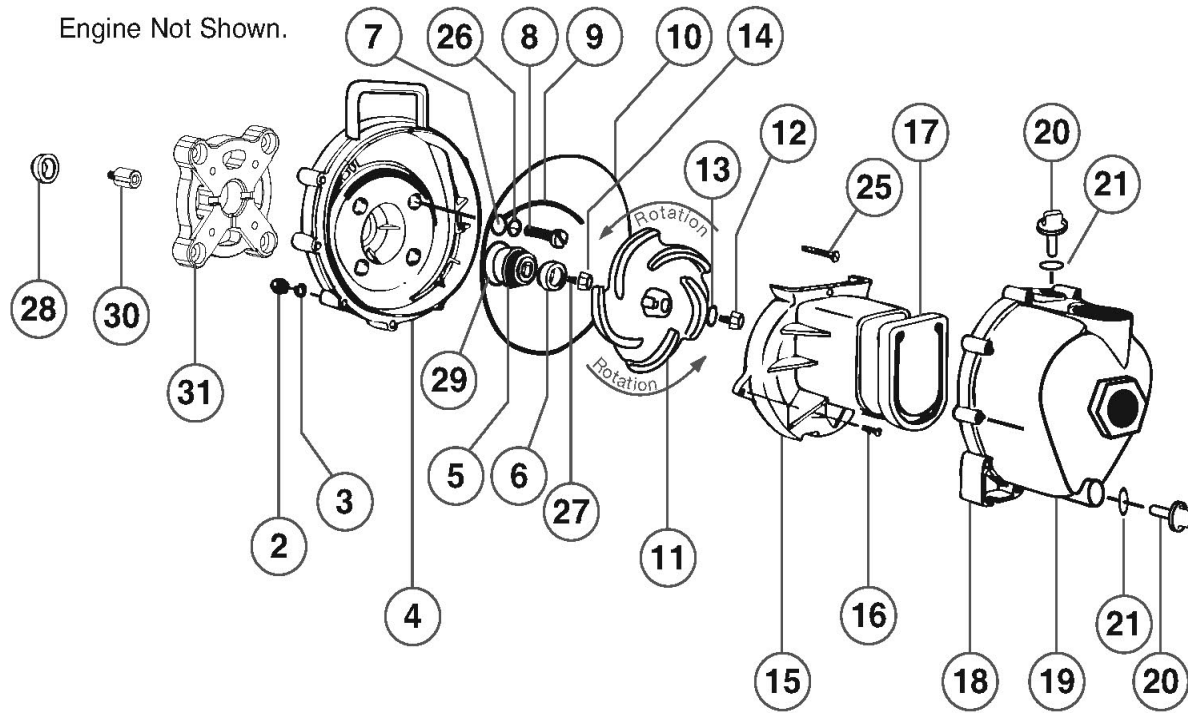

REPLACEMENT PARTS 2" POLYPROPYLENE CHEMICAL SERVICE PUMP

NO.	DESCRIPTION	PER	PART NO.	NO.	DESCRIPTION	PER	PART NO.
2	Body Nuts SS	10	V07019	20	Prime / Drain Plug	2	12777
3	Lock Washer SS	10	V07018	21	Prime / Drain Plug O-Ring+	2	UV15163V
4	Poly Pump Rear Bracket	1	12703A	25	Upper Volute Screw SS	1	12900T
5 & 6	Seal Assembly+	1	12729VA	26	Rear Bracket Washer SS	1	12901T
7	Screw Heads "O" Ring+	4	12717V	27	Impeller Key	1	12902A
8	Bracket Screws SS	4	12715AT	28	Poly Pump Slinger+	1	12716
9	O-Ring Segment+	1	12754V	29	O-Ring for Seal Assembly+	1	12710V
10	Body O-Ring+	1	12719AV	30	1" Extension for ³ / ₄ " Engine Shaft	1	12051
11	5 Vane Poly Pump Impeller+	1	12772	31	Poly Pump Engine Spacer	1	12048
12	Impeller Bolt SS	1	12785AT	N/S	Repair Kit	1	12003VAT
13	Impeller Bolt Gasket+	1	12774VA	N/S	Repair Kit	1	12005VAT
14	Impeller Hex Nut	1	12775A	N/S	Complete Bearing Pedestal	1	12882A
15	Poly Pump Volute	1	12702A	N/S	Impeller Removal Bolt +	1	12099
16	Volute Screws SS	2	12725T				
17	FKM (viton type) Poly Pump Check Valve+	1	12705V				
18	Poly Pump Body	1	12712AV				
19	Body Screws SS	10	12720				

All Items Shown with a "+" Included In Repair Kit

The Spray Tech part number can be derived by adding the prefix 'TE' to the listed Banjo part numbers.



2" Polypropylene Self-Priming Centrifugal Pump Electric Motor Drive Pumps

FEATURES

- Precision molded construction.
- Lightweight.
- Corrosion resistant.
- Superior design.
- Low maintenance.

• Maximum Motor Protection!

We have designed the new Banjo poly pump to protect the motor seal in the event of pump seal failure. We have separated the pump from the motor by 1" spacer and installed a special slinger/shaft seal that completely protects the engine from any corrosive fluids. This new slinger design is the best in the poly pump industry at protecting your motor.



CAUTION-WARNING: Please do not run pump dry, restrict or reduce port sizes, or dead head pump. This could cause component failure to pump.

DO NOT USE WITH FLAMMABLE LIQUIDS.

ELECTRIC MOTOR DRIVE PUMPS

PART NO.	DESCRIPTION	HP
234PPE5V	2" X 2" Polypropylene w/ 5.0 HP Three Phase Electric Motor w/FKM (viton type) Elastomers	5
234PPE51V	2" X 2" Polypropylene w/ 5.0 HP Single Phase Electric Motor w/FKM (viton type) Elastomers	5
150PEO	1-1/2" Polypropylene Pump w/ C Face Adapter	NA
200PEO	2" Polypropylene Pump w/ C Face Adapter	NA

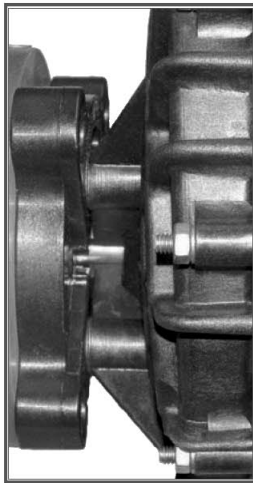

12756 - 56C Frame Adapter Kit

The 12756 spacer kit includes the poly adapter, adapter shaft, and related hardware to attach a Banjo Poly Pump to a 56C frame electric motor.

NOTE: Advanced installation techniques, and pump shimming required with this kit.

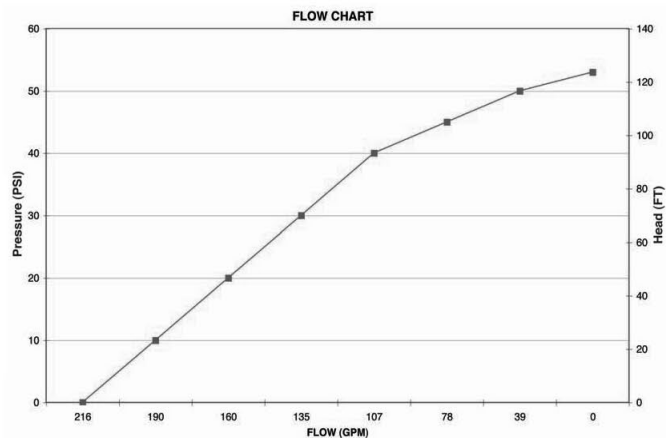

The Spray Tech part number can be derived by adding the prefix 'TE' to the listed Banjo part numbers.

BANJO PUMPS

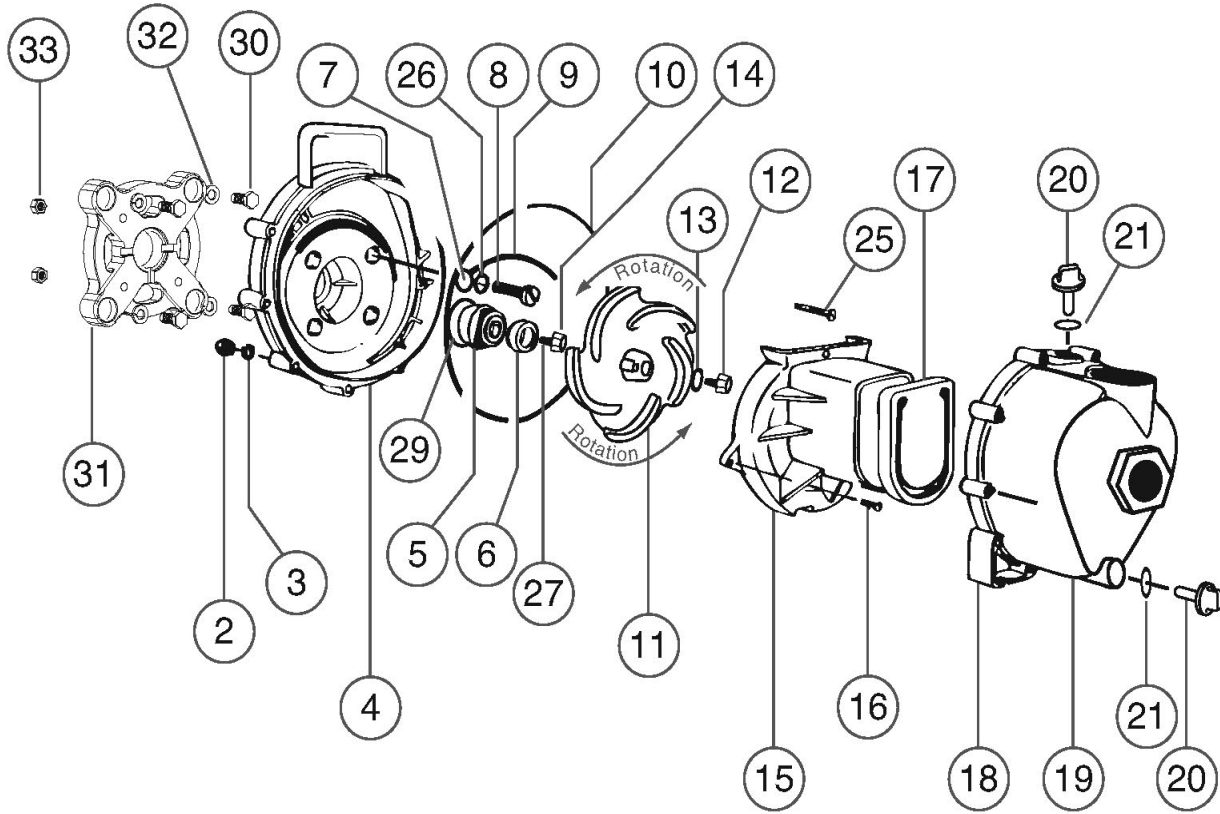

REPLACEMENT PARTS 2" NEW DESIGN ELECTRIC MOTOR POLY PUMP

NO.	DESCRIPTION	PER	PART NO.	NO.	DESCRIPTION	PER	PART NO.
2	Body Nuts SS	10	V07019	20	Prime / Drain Plug	2	12777
3	Lock Washer SS	10	V07018	21	Prime / Drain Plug O-Ring	2	UV15163V
4	Poly Pump Rear Bracket	1	12703A	25	Upper Volute Screw SS	1	12900
5 & 6	FKM (viton type) Seal Assembly	1	12713V	26	Rear Bracket Washer SS	1	12901
7	Screw Heads "O" Ring	4	12717V	27	Impeller Key	1	12902A
8	Stainless Steel Rear Bracket Bolts	4	BF107	29	O-Ring for Seal Assembly	1	12710V
9	O-Ring Segment+	1	12754V	30	Bolt for 56C Frame Adapter	8	17704
10	Body O-Ring+	1	12719AV	31	56C Frame Adapter	1	12046
11	5 Vane Poly Pump Impeller	1	12772	32	Lock Washer For 56C Frame Adapter	8	V20018
12	Impeller Bolt SS	1	12765A	33	Nut For 56C Frame Adapter	4	V10119
13	Impeller Bolt Gasket	1	12774VA	N/S	Base Plate	1	17701
14	Impeller Hex Nut	1	12775A	N/S	Impeller Removal Bolt	1	12099
15	Poly Pump Volute	1	12702A				
16	Volute Screws SS	2	12725				
17	FKM (viton type) Poly Pump Check Valve	1	12705V				
18	Poly Pump Body	1	12712AV				
19	Body Screws SS	10	12720				

The Spray Tech part number can be derived by adding the prefix 'TE' to the listed Banjo part numbers.



3" Poly Self Priming Centrifugal Pumps

PUMP FEATURES

- High strength polypropylene.
- Corrosion resistant.
- Lightweight – Portable.
- High Performance impellers.

APPLICATIONS

- Agricultural Pump.
- Contractor pump.
- Emergency use: fires & floods.



300PH-6
6.5 HP HONDA PUMP



300P8
8HP BRIGGS & STRATTON INTEK PRO PUMP

3" POLYPROPYLENE PUMPS

PART NO.	DESCRIPTION	HP
300P8PRO	3" Poly Pump complete w/ 8hp Briggs & Stratton Intek Pro	8
300P6VAN	3" Poly Pump complete w/ 6hp Briggs & Stratton Vanguard	6
300PH 6	3" Poly Pump complete w/ 6.5hp Honda	6.5
300PB	3" Poly Pump with Bearing Pedestal $\frac{3}{4}$ " Shaft	N/A
300PO	3" Poly Pump Only (For Gas Engines) $\frac{3}{4}$ " Shaft	N/A



PEDESTAL PUMP 300PB & PUMP ONLY 300PO

CAUTION-WARNING: Please do not run pump dry, restrict or reduce port sizes, or dead head pump. This could cause component failure to pump.

DO NOT USE WITH FLAMMABLE LIQUIDS.

NOTE: Engine warranty service available at authorized Briggs & Stratton and Honda dealers.

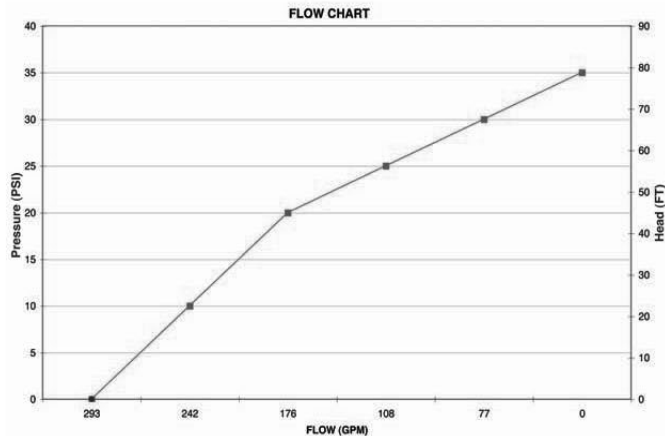

The Spray Tech part number can be derived by adding the prefix 'TE' to the listed Banjo part numbers.

BANJO PUMPS

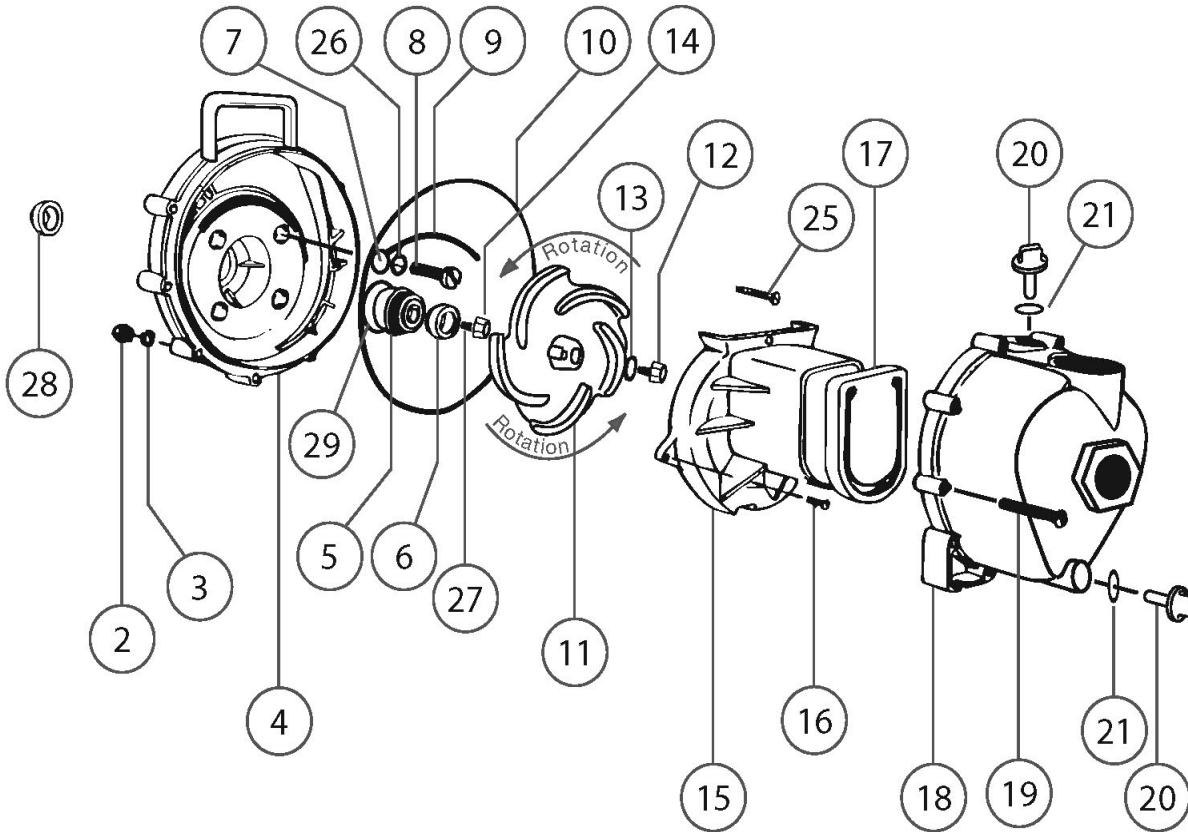

REPLACEMENT PARTS 3" POLY PUMP FOR PUMPS MANUFACTURED BEGINNING SEPT. 1996

NO.	DESCRIPTION	PER	PART NO.	NO.	DESCRIPTION	PER	PART NO.
2	Body Nuts SS	10	V07019	18	Poly Pump Body Assembly	1	13712
3	Lock Washer SS	10	V07018	19	Body Screws SS	10	12720
4	Poly Pump Rear Bracket	1	12703A	20	Prime / Drain Plug	2	13777
5 & 6	Seal Assembly*+	1	12713	21	Prime / Drain Plug O-Ring*	2	13778
7	Screw Heads "O" Ring*+	4	12717	25	Upper Volute Screw SS	1	12900
8	Bracket Screws SS	4	12715A	26	Rear Bracket Washer SS	1	12901
9	O-Ring Segment*+	1	12754	27	Impeller Key	1	12902A
10	Body O-Ring*+	1	12719A	28	Poly Pump Slinger*+	1	12716
11	4 Vane Poly Pump Impeller+	1	13771	29	O-Ring for Seal Assembly*+	1	12710
12	Impeller Bolt $\frac{5}{16}$ x 24 x 1.12 all except 8 HP Briggs	1	12765A	N/S	Complete Bearing Pedestal	1	12882A
12	Impeller Bolt $\frac{3}{8}$ x 24 x 1.00 (for 8 HP Briggs)	1	13765	N/S	Pump Repair Kit — 4 Vane Impeller (Consists Of Items Marked With +)	1	13000
13	Impeller Bolt Gasket*+	1	12774VA	N/S	Pump Seal/O-Ring Kit (Consists Of Items Marked with *)	1	13999
14	Impeller Hex Nut	1	12775A				
15	Poly Pump Volute	1	13702				
16	Volute Screws SS	2	12725				
17	Poly Pump Check Valve+	1	12705				

The Spray Tech part number can be derived by adding the prefix 'TE' to the listed Banjo part numbers.



2" Cast Iron 222 Series Pump

PUMP FEATURES

- Cast iron construction for rugged dependable service.
- Carbon ceramic seal with stainless steel cup and spring with FKM (viton type) rubber.
- Replaceable inlet and outlet flanges.
- Dynamically balanced impeller.
- Pump end separated from engine.
- Heavy duty slinger seal on motor shaft.
- Large weep holes between pump end and engine.
- "V" Shaped for Quicker Priming.



6.5 BRIGGS & STRATTON INTEK MOTOR FEATURES (RIGHT)

- Cast Iron Cylinder Sleeve.
- Heavy Duty Flywheel.
- Overhead Valve.
- High Oil Fill
- Oil Guard® Low Oil Sensor.
- Breather Through Air Cleaner.

HONDA ENGINE FEATURES (BELOW)

- GX Series Commercial Grade.
- Legendary Reliability/Durability.
- Powerful Overhead Valve (OHV).
- 2-year Commercial and Homeowner Warranty.
- Industrial 2-stage Air Filter.
- Quiet, Easy Starting.
- Oil Alert.



222 SERIES CI PUMP WITH BRIGGS & STRATTON

PART NO.	DESCRIPTION	QTY.	SIZE
222PI6PRO	2" CI Pump, 6.5 HP Intek OHV Pro Series Briggs & Stratton	1	2" X 2"

NOTE: Engine warranty service available at authorized Briggs & Stratton and Honda dealers.

SHIPPING: Truck shipments only.



222 SERIES CI PUMPS WITH HONDA ENGINES

PART NO.	DESCRIPTION	QTY.	SIZE
222PIH5	2" CI Pump, 5.5 HP OHV GX160 Honda	1	2" x 2"
222PIH6	2" CI Pump, 6.5 HP OHV GX200 Honda	1	2" x 2"
222PIH5E	2" CI Pump, 5.5 HP Electric Start GX160 Honda	1	2" x 2"

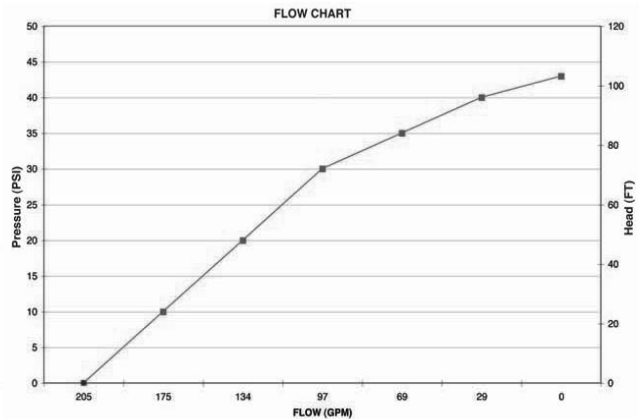

The Spray Tech part number can be derived by adding the prefix 'TE' to the listed Banjo part numbers.

BANJO PUMPS

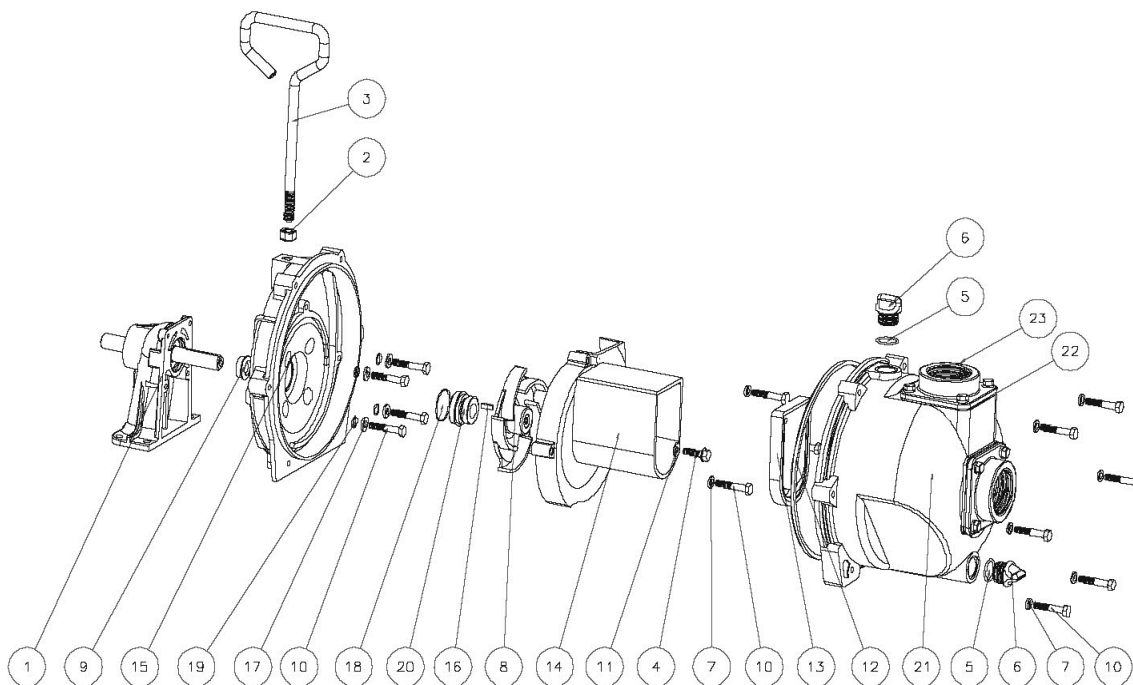

REPLACEMENT PARTS 222 SERIES CAST IRON PUMPS									
REF. NO.	PART NO.	DESCRIPTION	QTY. PER PUMP		REF. NO.	PART NO.	DESCRIPTION	QTY. PER PUMP	
1	12882A	Bearing Pedestal Assembly	1		17	12901	5/16" Flat Washer	4	
1	12600B	Hydraulic Pedestal Assembly	1		18	12710	2-029 O-Ring	1	
2	17010*	1/2" Jam Nut	1		19	12717*	2-011 O-Ring	4	
3	15022	2" Pump Handle	1		20	12713V*	Seal Assembly	1	
4	12765A	5/16-24 x 1.12 Impeller Bolt	1		20	12713SD	Severe Duty Seal	1	
5	13778*	2-119 O-Ring	2		21	15712	Pump Body Assembly	1	
6	13777	Prime/Drain Plug	2		22	17013	Flange Gasket	2	
7	V10118	5/16" Lockwasher	9		23	17000	Threaded Flange	2	
8	15772	5 Vane Impeller*	1		N/S	15751*	Bracket Shim	AS REQ 'D	
9	12716	Pump Slinger	1		N/S	17033	Z-Rails (PR)	1 PAIR	
10	12715A	HHCS 5/16-24x1.75	13		N/S	17034	HHCS 5/16-18 X 1 3/4" Zinc Plated	4	
11	12774VA*	Impeller Bolt Gasket	1		N/S	V10119	5/16"-18 Hex Nut	4	
12	12719A*	2-375 Body O-Ring	1		N/S	V10118	5/16" Lockwasher	4	
13	12705*	Check Valve	1		N/S	15000*	REPAIR KIT	1	
14	15702	Volute	1		N/S	15999	SEAL KIT (repair kit w/o impeller)	1	
15	15703	Rear Bracket	1		N/S	15000V	REPAIR KIT FKM (viton type)	1	
16	12902A	3/16 sq x 5/8" Key*	1		N/S	15999V	SEAL KIT FKM (viton type)	1	

Pump Repair Kits Contain Items Marked With Asterisk

NOTE: EPDM Gaskets, Seals and O-rings used in the following assemblies unless otherwise noted: 222PBI, 222PIHY, 222PI5, 222PIH5, 222POI.

The Spray Tech part number can be derived by adding the prefix 'TE' to the listed Banjo part numbers.



2" Cast Iron 222 Series Pump



2" CAST IRON PUMP ONLY

- Comes complete and ready for attachment to gasoline engine ($\frac{3}{4}$ " straight keyed shaft required).

2" CAST IRON PEDESTAL PUMP

- Easily adaptable to electric motor (flexible coupling not included).
- $\frac{3}{4}$ " straight keyed shaft.

PUMP FEATURES

- Cast iron construction for rugged dependable service.
- Carbon ceramic seal with stainless steel cup and spring with FKM (viton type) rubber.
- Replaceable inlet and outlet flanges.
- Dynamically balanced impeller.



222 SERIES C/I PEDESTAL PUMP

PART NO.	DESCRIPTION	QTY.	SIZE
222PBI	2" Cast Iron Pump/Bearing Pedestal with $\frac{3}{4}$ " Straight Keyed Shaft	1	2" X 2"

* Recommended for use with 5 h.p. electric motor @ 3600 RPM.

222 SERIES C/I PUMP ONLY FOR ENGINE

PART NO.	DESCRIPTION	QTY.	SIZE
222POI	2" C/I Pump Only (full impeller)	1	2" X 2"
225POI*	2" C/I Pump Only (trimmed impeller)	1	2" X 2"

* Recommended for use with 10 pound per gallon material or more.



The Spray Tech part number can be derived by adding the prefix 'TE' to the listed Banjo part numbers.

BANJO® PUMPS

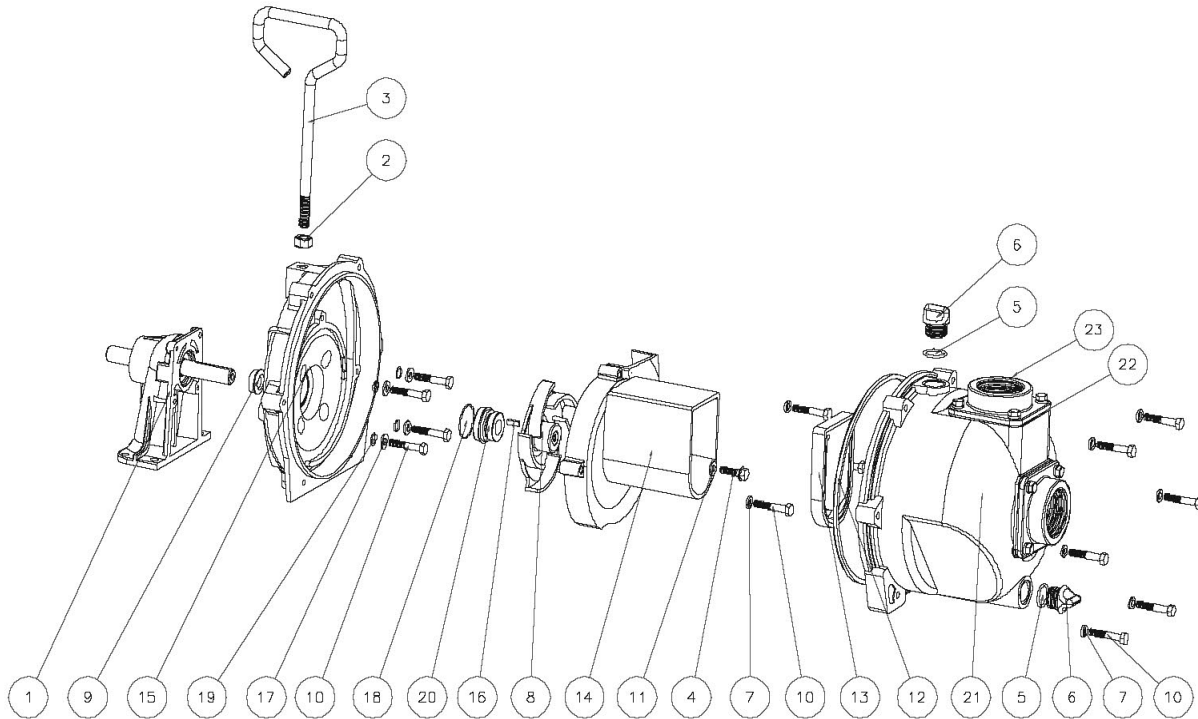

REPLACEMENT PARTS 222 SERIES CAST IRON PUMPS

REF. NO.	PART NO.	DESCRIPTION	QTY. PER PUMP	REF. NO.	PART NO.	DESCRIPTION	QTY. PER PUMP
1	12882A	Bearing Pedestal Assembly	1	17	12901	5/16" Flat Washer	4
1	12600B	Hydraulic Pedestal Assembly	1	18	12710	2-029 O-Ring	1
2	17010*	1/2" Jam Nut	1	19	12717*	2-011 O-Ring	4
3	15022	2" Pump Handle	1	20	12713V*	Seal Assembly	1
4	12765A	5/16-24 x 1.12 Impeller Bolt	1	20	12713SD	Severe Duty Seal	1
5	13778*	2-119 O-Ring	2	21	15712	Pump Body Assembly	1
6	13777	Prime/Drain Plug	2	22	17013	Flange Gasket	2
7	V10118	5/16" Lockwasher	9	23	17000	Threaded Flange	2
8	15772	5 Vane Impeller*	1	N/S	15751*	Bracket Shim	AS REQ 'D
9	12716	Pump Slinger	1	N/S	17033	Z-Rails (PR)	1 PAIR
10	12715A	HHCS 5/16-24x1.75	13	N/S	17034	HHCS 5/16-18 X 1 3/4" Zinc Plated	4
11	12774VA*	Impeller Bolt Gasket	1	N/S	V10119	5/16"-18 Hex Nut	4
12	12719A*	2-375 Body O-Ring	1	N/S	V10118	5/16" Lockwasher	4
13	12705*	Check Valve	1	N/S	15000*	REPAIR KIT	1
14	15702	Volute	1	N/S	15999	SEAL KIT (repair kit w/o impeller)	1
15	15703	Rear Bracket	1	N/S	15000V	REPAIR KIT FKM (viton type)	1
16	12902A	3/16 sq x 5/8" Key*	1	N/S	15999V	SEAL KIT FKM (viton type)	1

Pump Repair Kits Contain Items Marked With Asterisk

NOTE: EPDM Gaskets, Seals and O-rings used in the following assemblies unless otherwise noted: 222PBI, 222PIHY, 222PI5, 222PIH5, 222POI.

The Spray Tech part number can be derived by adding the prefix 'TE' to the listed Banjo part numbers.



222 Series Close Coupled C/I Electric Driven Pumps

FEATURES

- Cast iron construction for rugged dependable service.
- Stainless steel shaft sleeve to protect engine shaft.
- Carbon ceramic seal with stainless steel cup and spring with FKM (viton type) rubber.
- Replaceable inlet and outlet flanges.
- Dynamically balanced impeller.
- Pump end separated from engine.
- Heavy duty slinger seal on motor shaft.
- Large weep holes between pump end and engine.
- "V" shaped for quicker priming.



CAUTION-WARNING: Please do not run pumps dry, restrict or reduce port sizes or dead head pumps. This could cause component failure to pump. No Flammables.

DO NOT USE WITH FLAMMABLE LIQUIDS.

NOTE: Truck shipments only. Motor warranty service available at authorized dealers.

222 SERIES CLOSE COUPLED ELECTRIC DRIVEN PUMP - CAST IRON

PART NO.	DESCRIPTION	SIZE	HP
222PIE5	2" CI Pump, 5 HP, 3450 RPM Motor, 3 Phase	2" x 2"	5
222PIE51	2" CI Pump, 5 HP, 3450 RPM Motor, Single Phase	2" x 2"	5

COMPLETE PUMP WITH STANDARD-E (EFFICIENT) INDUSTRIAL ELECTRIC MOTORS!

MOTOR FEATURES:

- Pressure cast aluminum end plates with ribbed design for rigidity.
- Ball bearings, locked drive end bearing.
- Heavy gauge steel frame.
- Motors wound with inverter spike resistance magnet wire.
- Mounted complete on Heavy Duty Cast Iron Base Plate.
- 230 V Motors.

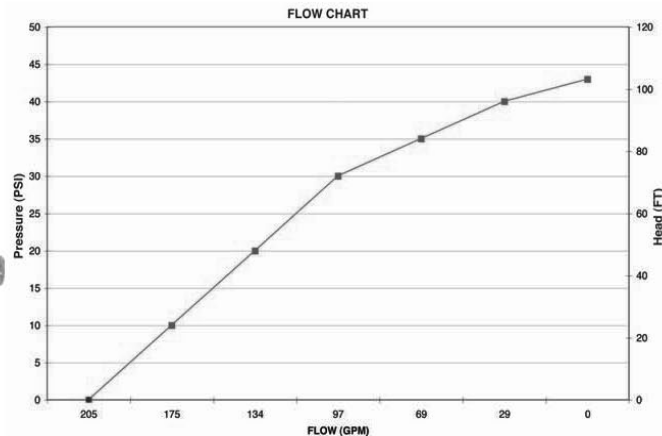

The Spray Tech part number can be derived by adding the prefix 'TE' to the listed Banjo part numbers.

BANJO PUMPS

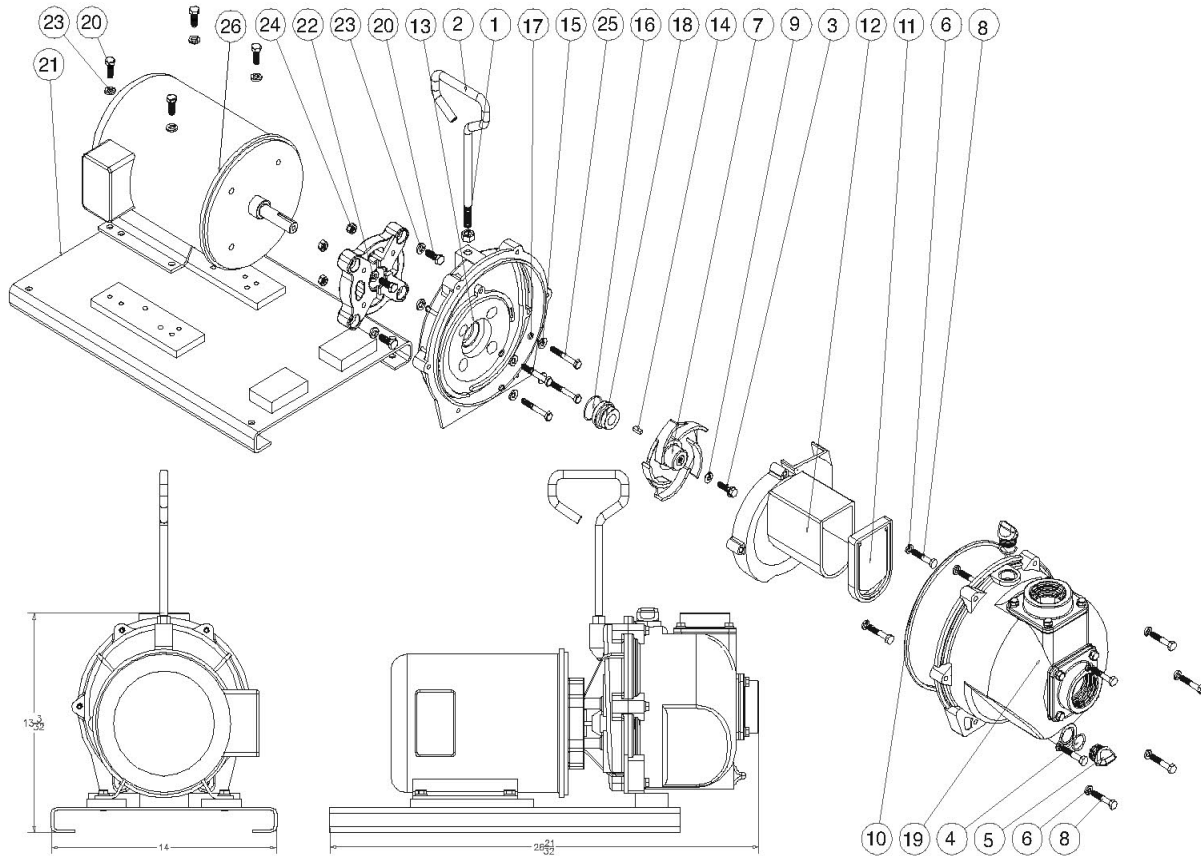

REPLACEMENT PARTS 222 SERIES CLOSE COUPLED ELECTRIC DRIVEN PUMPS

REF. NO.	PART NO.	DESCRIPTION	QTY. PER PUMP	REF. NO.	PART NO.	DESCRIPTION	QTY. PER PUMP
1	17010*	1/2" Jam Nut	1	17	12717*	2-011 O-Ring	4
2	15022	2" Pump Handle	1	18	12713V*	Seal Assembly	1
3	12765A	5/16-24x1.125 Impeller Bolt	1	18	12713SD	Severe Duty Seal	1
4	13778*	2-119 O-Ring	2	19	15712	Pump Body Assembly	1
5	13777	Prima/Drain Plug	2	20	17704	3/16" - 16 X 1.25 HHCS Bolt	8
6	V10118	5/16" Lockwasher	9	21	17701	C-Faced Base Plate	1
7	15772	5 Vane Impeller*	1	22	12046	56C Adapter	1
8	12715A	HHCS 5/16-24x1.75	13	23	V20018	3/8" Lockwasher	8
9	12774VA*	Impeller Bolt Gasket	1	24	V20019	3/8" 18 Hex Nut	4
10	12719A*	2-375 Body O-Ring	1	25	BF107	5/16" - 18 X 2 1/4" HHCS Bolt	4
11	12705*	Check Valve	1	26	BEM5-182CZ	5 HP 3450 RPM Three Phase MTR	1
12	15702	Volute	1	26	BEM51-182CZ	5HP 3450 RPM Single Phase MTR	1
13	15703	Rear Bracket	1	N/S	15000*	REPAIR KIT	1
14	12902A	3/16" Square X 5/8" Key	1	N/S	15999	SEAL KIT(repair kit without impeller)	1
15	12901	5/16" Flat Washer	4	N/S	15000V	REPAIR KIT FKm (miton type)	1
16	12710	2-029 O-Ring	1	N/S	15999V	SEAL KIT FKm (miton type)	1

Valve Repair Kits Contain Items Marked With Asterisk

NOTE: EPDM Gaskets, Seals and O-rings used in the following assemblies unless otherwise noted: 222PBI, 222PIHY, 222PI5, 222PIH5, 222POI.

The Spray Tech part number can be derived by adding the prefix 'TE' to the listed Banjo part numbers.

BANJO®

333 Series Pumps

FEATURES

- Durable cast iron construction.
- Dynamically balanced impeller.
- Replaceable inlet and outlet flanges.
- Graphite loaded silicon carbide seal with stainless steel CUP and spring with FKM (viton type) rubber.
- Pump end separated from engine.
- Large weep holes between pump end and engine.
- "V" Shaped for Quicker Priming.



333PIH13



333PI16



333 SERIES CAST IRON PUMPS

PART NO.	DESCRIPTION	QTY.	SIZE
333PI16	3" Cast Iron Pump with 16 HP Briggs Vanguard Engine Electric Start with pull rope	1	3" X 3"
333PBI	3" Cast Iron Pump with 3" Inlet and 3" Outlet/Bearing pedestal w/1" Shaft	1	3" X 3"
333PIH13	3" Cast Iron Pump with 13 HP Honda Engine Electric Start with pull rope	1	3" X 3"

Graphite Loaded Silicon Carbide Seal for Longer Seal Life.



Better Run Dry Capabilities!

NOTE: Engine warranty service available at authorized Honda and Briggs & Stratton dealers.

SHIPPING: Truck shipments only.

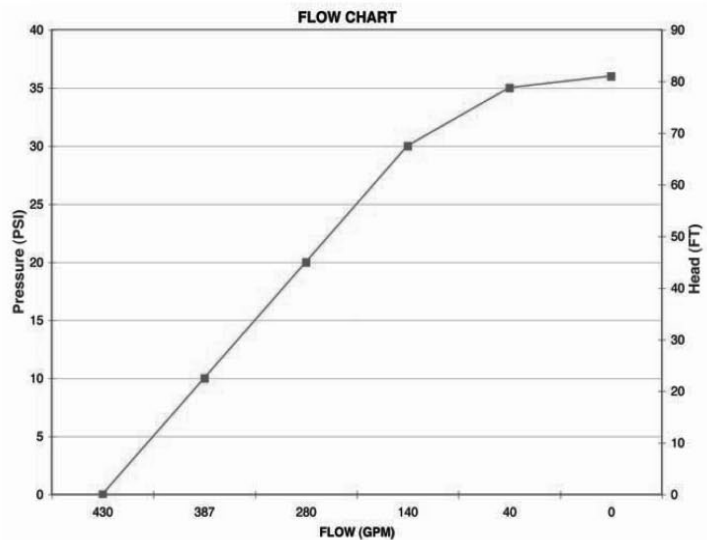

The Spray Tech part number can be derived by adding the prefix 'TE' to the listed Banjo part numbers.

BANJO PUMPS

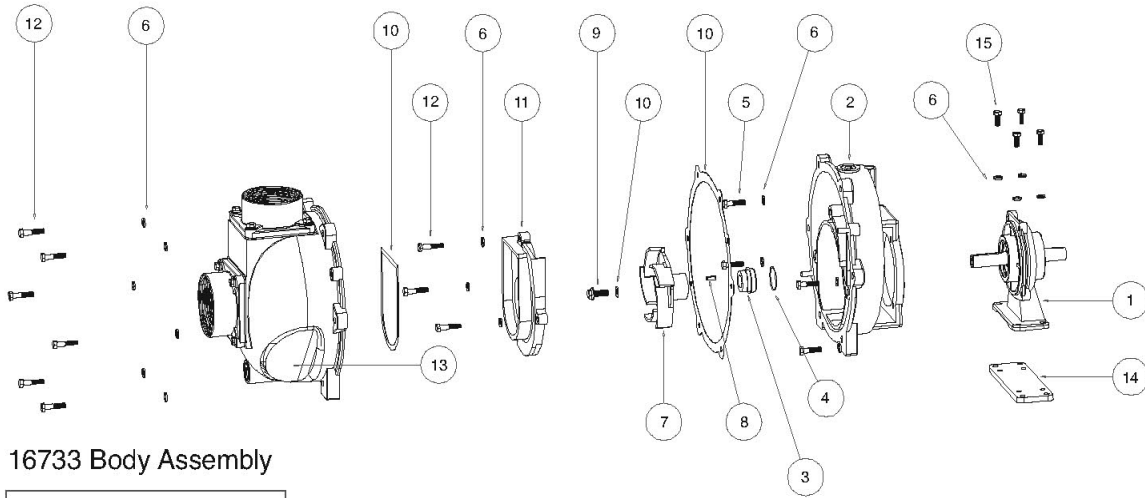

16733 Body Assembly

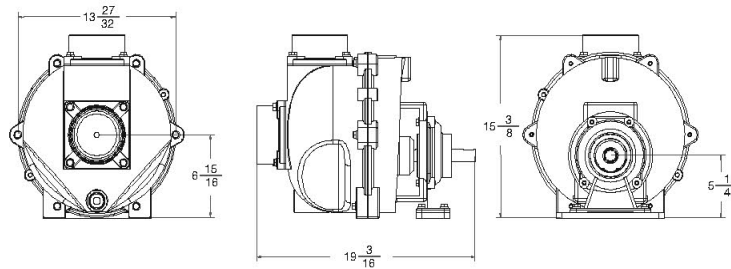
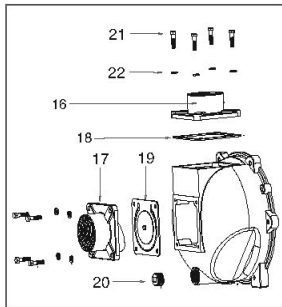

REPLACEMENT PARTS – 333PIH13 - 333PI16 - 333PBI

ITEM	PART NO.	DESCRIPTION	333PIH13	333PI16	333PBI	QTY.
N/S	16099*	Impeller Removal Bolt	~	~	~	1
1	18500	Bearing Pedestal	~	~	~	1
2	16704	3* Hi. Vol. Rear Bracket, 500 gpm	~	~	~	1
3	16713*	4* Pump Mechanical Seal	~	~	~	1
4	16710*	O-Ring F/16713 Mechanical Seal	~	~	~	1
5	17704	Cap Scr. 3/8" - 16 x 1.25" Pedestal. Mt. SS	~	~	~	4
6	V20018	3/8" SS Lock Washer	~	~	~	17
7	16773*	3* Impeller for 333PBI & 333PI16	~	~	~	1
7	16774*	3* Impeller for 333PIH13 & 333POI	~	~	~	1
8	16901*	1/4" Sq. 3/4" Key Stock	~	~	~	1
9	16765*	Impeller Bolt, 7/16"-20x1.25 HFS	~	~	~	1
10	16019*	Gasket Set	~	~	~	1
11	16702	4* Pump Volute	~	~	~	1
12	V20011SS	3/8" - 16 x 1.75" SS Bolt	~	~	~	9
13	16733	333 Pump Body, Assembled	~	~	~	1
14	18511	Adapter Plate f/18501 444 Pump	~	~	~	1
15	18512	3/8" - 16 x 0.875" HHCS, SS	~	~	~	4
N/S	16751*	4* Pump Bracket Shim Set (as required)	~	~	~	1
N/S	16752*	444 Pump Impeller Shim (as required)	~	~	~	1
N/S	18033	Handle 5/8"-11 Thread.	~	~	~	4
N/S	18034	Nut, Jam 5/8"-11 Thread. SS	~	~	~	1
16	18001	3* Pump Outlet Flange	~	~	~	1
17	16003	3* Pump Inlet Flange	~	~	~	1
18	16706	Outlet Gasket	~	~	~	1
19	16011	Inlet Gasket with Check	~	~	~	1
20	18002	1" NPT Plug	~	~	~	1
21	18027	3/8" - 16 x 1.50" HHCS	~	~	~	8
22	V20018	3/8" SS Lock Washer	~	~	~	8
N/S	16101	333 Pump Repair Kit (Note: Kit part numbers marked with a ***)	~	~	~	1

The Spray Tech part number can be derived by adding the prefix 'TE' to the listed Banjo part numbers.

BANJO®

444 Series Pumps

FEATURES

- Durable cast iron construction.
- Dynamically balanced impeller.
- Replaceable inlet and outlet flanges.
- Graphite loaded silicon carbide seal with stainless steel CUP and spring with FKM (viton type) rubber.
- Pump end separated from engine.
- Large weep holes between pump end and engine.
- "V" Shaped for Quicker Priming.



444 SERIES CAST IRON PUMPS

PART NO.	DESCRIPTION	SIZE	QTY.
444PIH24	4" Cast Iron Pump with 24 HP Honda Engine	4" X 4"	1
444PBI	4" Cast Iron Pump/Bearing Pedestal with a 1" Shaft	4" X 4"	1
433PBI	4" Cast Iron Pump with 4" Inlet 3" Outlet/Bearing Pedestal with a 1" Shaft	4" X 3"	1

Graphite Loaded Silicon Carbide Seal for Longer Seal Life.



Better Run Dry Capabilities!

NOTE: Engine warranty service available at authorized Honda dealers.

SHIPPING: Truck shipments only.

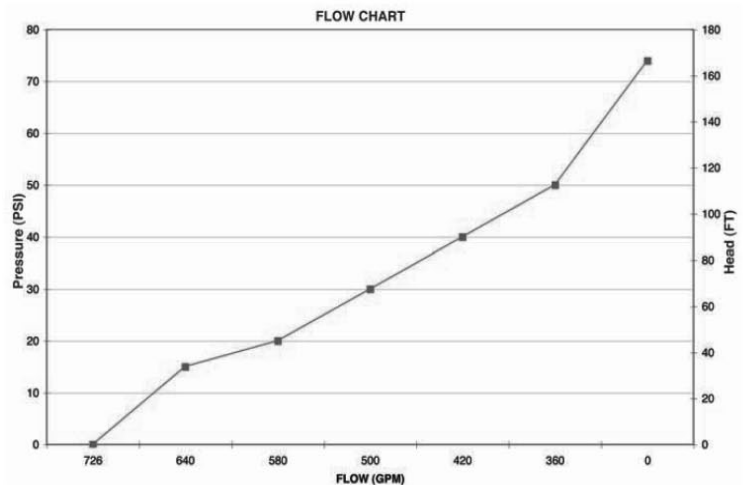

The Spray Tech part number can be derived by adding the prefix 'TE' to the listed Banjo part numbers.

BANJO PUMPS

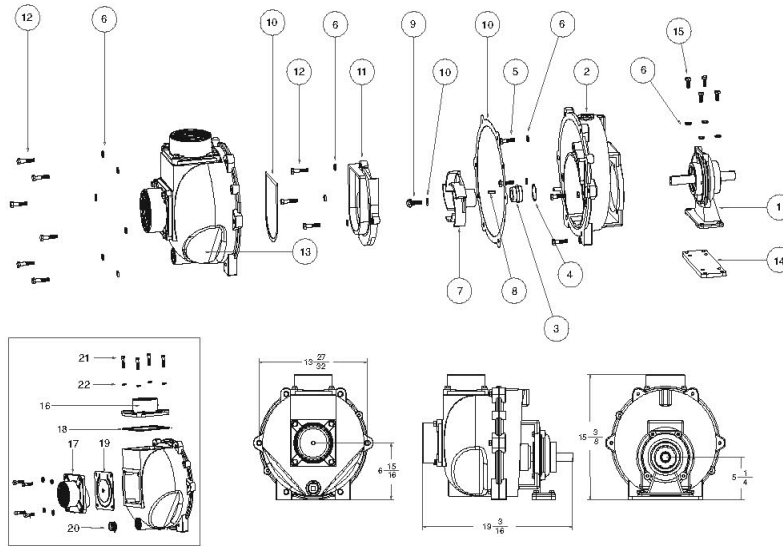

REPLACEMENT PARTS — 444PI18 - 444PBI - 433PBI - 444PIH24

ITEM	PART NO.	DESCRIPTION	444PI18	444PBI	433PBI	444PIH24	QTY.
N/S	16099*+	Impeller Removal Bolt	~	~	~	~	1
1	18500	Bearing Pedestal	~	~	~	~	1
2	16703	4 Rear Pump Bracket	~	~			1
2	16704	3* Hi. Vol. Rear Bracket, 500 gpm			~		1
2	16707	4* 24 HP Rear Bracket, Assembled				~	1
3	16713*+	4* Pump Mechanical Seal for 444PBI & 433PBI	~	~	~		1
3	18435	4* Pump Mechanical Seal for 444PIH24				~	1
4	16710*+	O-Ring F/16713 Mechanical Seal	~	~	~		1
5	17704	Cap Scr. 3/8" - 16 x 1.25" Pedestal. Mt. SS	~	~	~		4
6	V20018	3/8" SS Lock Washer	~	~	~	~	17
7	16772+	4* 5 Vane Impeller	~	~			1
7	16773*	3* Impeller for 433 Pump			~		1
7	16775	4* 24 HP Pump Impeller, 6 vane				~	1
8	16901*+	1/4" Sq. 3/4" Key Stock	~	~	~	~	1
9	16765*+	Impeller Bolt, 1/16"-20x1.25 HFS	~	~	~	~	1
10	16019*+	Gasket Set	~	~	~	~	1
11	16702	4* Pump Volute	~	~	~	~	1
12	V20011SS	3/8" - 16 x 1.75" SS Bolt	~	~	~	~	9
13	16712	4* Hi Vol. Pump Body, Assembled	~	~			1
13	16743	3* Hi Vol. Pump Body, Assembled			~		1
14	18511	Adapter Plate f/18501 444 Pump	~	~	~		1
15	18512	3/8" - 16 x 0.875" HHCS, SS	~	~	~		4
N/S	16751*+	4* Pump Bracket Shim Set (as required)	~	~	~	~	1
N/S	16752*+	444 Pump Impeller Shim (as required)	~	~	~	~	1
N/S	18033	Handle 5/8"-11 Thread.	~	~	~	~	4
N/S	18034	Nut, Jam 5/8"-11 Thread. SS	~	~	~	~	1
16	16000	4* Pump Outlet Flange	~	~		~	1
16	16001	3* Pump Outlet Flange			~		1
17	16002	4* Pump Inlet Flange	~	~	~	~	1
18	16706	Inlet Gasket with Check	~	~	~	~	1
19	16011	Outlet Gasket	~	~		~	1
20	18002	1" NPT Plug	~	~	~	~	1
21	18027	3/8" - 16 x 1.50" HHCS	~	~	~	~	8
22	V20018	3/8" SS Lock Washer	~	~	~	~	8
N/S	16101	433 Pump Repair Kit (Note: Kit part numbers marked with a "**")	~	~	~		1
N/S	16100	444 Pump Repair Kit (Note: Kit part numbers marked with a "+")	~	~		~	1

The Spray Tech part number can be derived by adding the prefix 'TE' to the listed Banjo part numbers.



2" Gas Driven Cast Iron Self-Priming Centrifugal Pump

FEATURES

- Cast iron construction for rugged dependable service.
- Stainless steel shaft sleeve to protect engine shaft.
- Carbon ceramic seal with stainless steel cup and spring with FKM (viton type) rubber.
- Replaceable inlet and outlet flanges.
- Dynamically balanced impeller.



CAUTION-WARNING: Please do not run pumps dry, restrict or reduce port sizes or dead head pumps. This could cause component failure to pump.

DO NOT USE WITH FLAMMABLE LIQUIDS.

2" SELF PRIMING CENTRIFUGAL PUMPS W/BRIGGS & STRATTON

PART NO.	DESCRIPTION	SIZE	HP
150PI-3	1 1/2" x 1 1/2" Cast Iron Pump x 3.5 HP Briggs	1 1/2"x1 1/2"	3.5
200PI-3	2" x 2" Cast Iron Pump x 3.5 HP Briggs	2" x 2"	3.5
200PI6PRO*	2" x 2" Cast Iron Pump x 6.5 HP Briggs Pro Series	2" x 2"	6



2" SELF PRIMING CENTRIFUGAL PUMPS W/HONDA ENGINE

PART NO.	DESCRIPTION	SIZE	HP
200PIH-5*	2" x 2" Cast Iron Pump x 5.5 HP Honda Engine	2" x 2"	5.5
200PIH5E*	2" x 2" Cast Iron Pump x 5.5 HP Honda Engine with Electric Start	2" x 2"	5.5

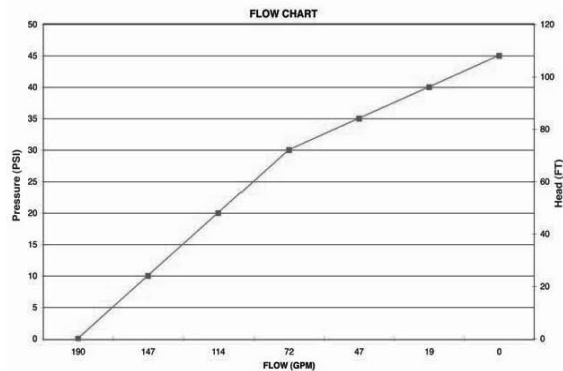

NOTE: Engine warranty service available at authorized Briggs & Stratton and Honda dealers.

SHIPPING: Pumps with an "ET" behind the part number are truck shipments only.



The Spray Tech part number can be derived by adding the prefix 'TE' to the listed Banjo part numbers.

BANJO PUMPS

1 1/2" & 2" CAST IRON PUMP

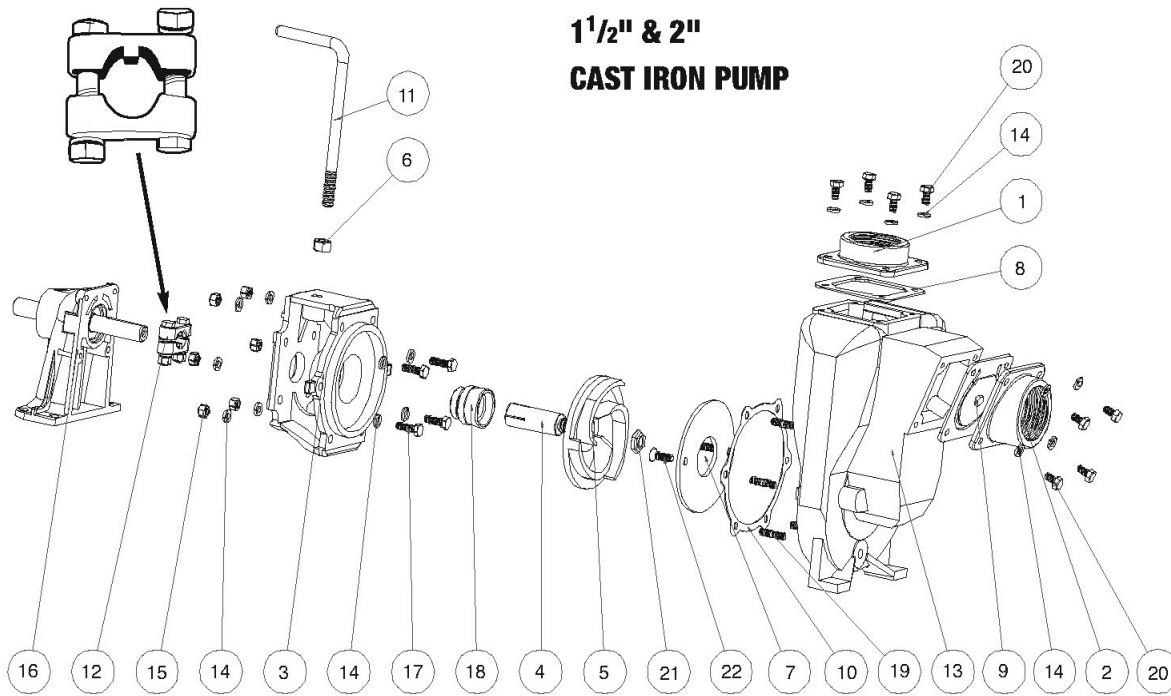

REPLACEMENT PARTS 1 1/2" & 2" CAST IRON PUMPS

REF. NO.	PART NO.	DESCRIPTION	QTY. PER PUMP	REF. NO.	PART NO.	DESCRIPTION	QTY. PER PUMP
1	17000	Flange-Outlet 2"	1 (2" Only)	N/S	12882R	Housing For Bearing Pedestal	1
1	17001	Flange-Outlet 1 1/2"	1 (1 1/2" Only)	N/S	12883R	Bearing Pedestal 3/4" Shaft Only	1
2	17002	Flange-Inlet 20" 2"	1 (2" Only)	N/S	12884	Internal Retaining Clip for Pedestal	1
2	17003	Flange-Inlet 20" 1 1/2"	1 (1 1/2" Only)	N/S	12883B	Pedestal Bearing	2
3	17004	Adapter-Gas Engine	1	16	12882A	Complete Pedestal Assy.(3/4"Shaft)	1
3	17046	C-Flange Adapter	1	17	17040	Cap Screw 5/16" - 24 x 1.00" NF	4
4	17005	Sleeve Drive 5/8" for electric motor	1 (1 Per Pump)	18	17028	Seal Assy. (EPDM)	1 (1 Per Pump)
4	*17006	Sleeve Drive 3/4" for gas engine	1 (1 Per Pump)	18	*17035	Seal Assy. FKM (viton type)	1 (1 Per Pump)
4	17007	Sleeve Drive 7/8" for electric motor	1 (1 Per Pump)	18	17035SD	Severe Duty Seal	1 (1 Per Pump)
5	*17008	Impeller - 5" (Standard)	1	19	17042	Stud	6
5	17008-4.6	Impeller - 4.6" (Trimmed)	1	20	17019	Capscrew 5/16" - 18 x 3/4"	8
5	17008-4.1	Impeller - 4.1" (Trimmed)	1	21	17009B	Nut, Hex 1/2" - 13 UNC	1
6	17010	Hex Nut 1/2" - 13UNF-RH	1	22	17130	C' Sink Flat Head Screw	2
7	*17011	Wear Plate	1	N/S	17032	1/4" Drain Plug	1 (Not Shown)
8	17013	EPDM Gasket	1	N/S	17033	Z Rails	Pair.
9	17016	Gasket-Check valve Assy.	1	N/S	17100	Pump Repair Kit (1 1/2" & 2")	1
10	*17018	Gasket Adapter	1	(Consists of items marked *)			
11	15022	Handle	1				
12	17023	Clamp 5/8", 3/4" Shaft Assy.(Old Style)	(1 Per Pump)				
1 2	17123	Clamp 5/8", 3/4" Shaft Assy.(Keyed)	(1 Per Pump)				
12	17024	Clamp 7/8" Shaft Assy.	(1 Per Pump)				
13	17026	Pump Housing	1				
14	V10118	5/16" Lockwasher	18				
15	V10119	5/16" - 18 Hex Nut S.S.	6				

The Spray Tech part number can be derived by adding the prefix 'TE' to the listed Banjo part numbers.

BANJO®

1 1/2" & 2" Cast Iron Pumps



IMPORTANT

- 2 horsepower motors can only be used at 1750 RPM.
- Banjo Pumps will not self-prime if a 1750 RPM motor is used.
- Recommended horsepower, listed below, is for water only. Heavier fluids may require additional horsepower or a trimmed impeller.

PUMP FEATURES

- Pump Only packs complete and ready for attachment to gasoline engine.
- Pedestal Pump for long coupling to electric motor.



CAST IRON PUMP ONLY			
PART NO.	DESCRIPTION	SIZE	HP
150POI	1 1/2" x 1 1/2" Cast Iron Pump Only	1 1/2" x 1 1/2"	N/A
200POI	2" x 2" Cast Iron Pump Only	2" x 2"	N/A

CAST IRON PEDESTAL PUMP			
PART NO.	DESCRIPTION	SIZE	HP
150PBI	1 1/2" x 1 1/2" C.I. Pump With Pedestal	1 1/2" x 1 1/2"	N/A
200PBI	2" x 2" C.I. Pump With Pedestal	2" x 2"	N/A

Note: 3/4" Straight Shaft for Long Coupling to Electric Motors

1 1/2" & 2" Cast Iron Pumps

FEATURES

- For close coupling electric motors.

CAUTION-WARNING: Please do not run pumps dry, restrict or reduce port sizes or dead head pumps. This could cause component failure to pump.

DO NOT USE WITH FLAMMABLE LIQUIDS.

CAST IRON C-FLANGE PUMPS			
PART NO.	DESCRIPTION	SIZE	HP
150POICF5/8	1 1/2" Cast Iron Pump with 5/8" Shaft Sleeve (3HR, 3450 RPM, 56C Frame Size Recommended)	1 1/2" x 1 1/2"	N/A
150POICF7/8	1 1/2" Cast Iron Pump with 7/8" Shaft Sleeve (3HR, 3450 RPM, 145TC Frame Size Recom.)	1 1/2" x 1 1/2"	N/A
200POICF5/8	2" Cast Iron Pump with 5/8" Shaft Sleeve (3HR, 3450 RPM, 56C Frame Size Recommended)	2" x 2"	N/A
200POICF7/8	2" Cast Iron Pump with 7/8" Shaft Sleeve (3HR, 3450 RPM, 145TC Frame Size Recom.)	2" x 2"	N/A
234POI	2" Cast Iron Pump with 184TC Frame Adapter	2" x 2"	N/A



The Spray Tech part number can be derived by adding the prefix 'TE' to the listed Banjo part numbers.

BANJO PUMPS

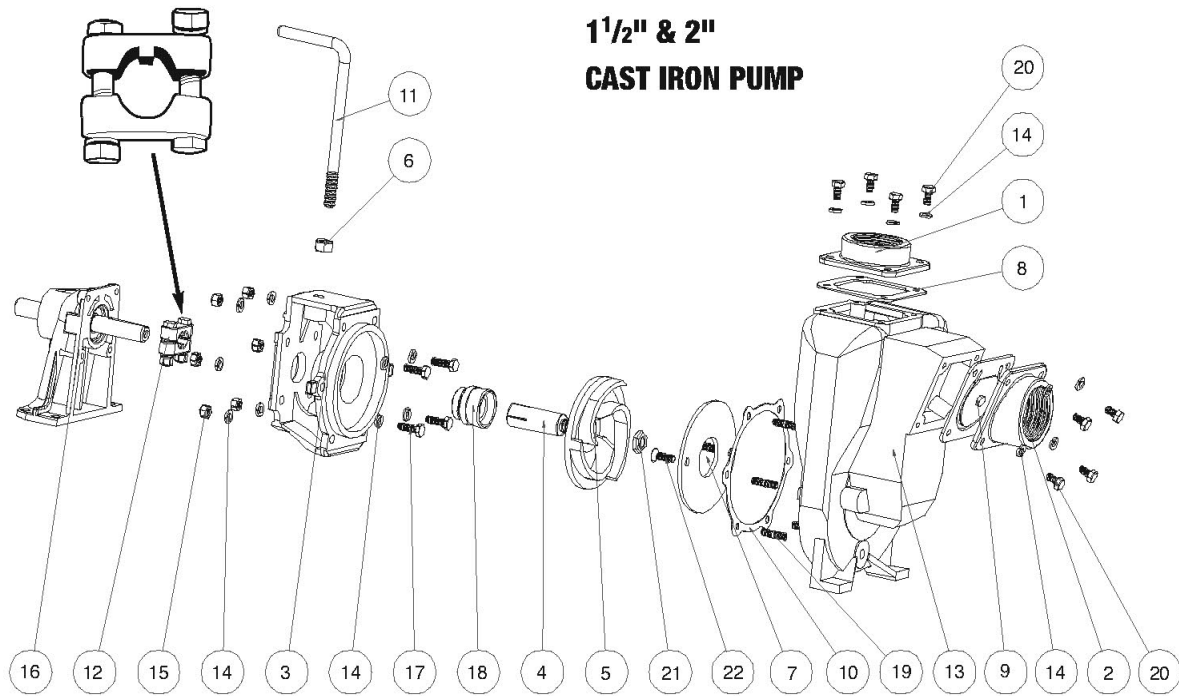

1 1/2" & 2" CAST IRON PUMP

REPLACEMENT PARTS 1 1/2" & 2" CAST IRON PUMPS

REF. NO.	PART NO.	DESCRIPTION	QTY. PER PUMP	REF. NO.	PART NO.	DESCRIPTION	QTY. PER PUMP
1	17000	Flange-Outlet 2"	1 (2" Only)	N/S	12882R	Housing For Bearing Pedestal	1
1	17001	Flange-Outlet 1 1/2"	1 (1 1/2" Only)	N/S	12883R	Bearing Pedestal 3/4" Shaft Only	1
2	17002	Flange-Inlet 20° 2"	1 (2" Only)	N/S	12884	Internal Retaining Clip for Pedestal	1
2	17003	Flange-Inlet 20° 1 1/2"	1 (1 1/2" Only)	N/S	12883B	Pedestal Bearing	2
3	17004	Adapter-Gas Engine	1	16	12882A	Complete Pedestal Assy.(3/4"Shaft)	1
3	17046	C-Flange Adapter	1	17	17040	Cap Screw 5/16" – 24 x 1.00" NF	4
4	17005	Sleeve Drive 5/8" for electric motor	1 (1 Per Pump)	18	17028	Seal Assy. (EPDM)	1(1 Per Pump)
4	*17006	Sleeve Drive 3/4" for gas engine	1 (1 Per Pump)	18	*17035	Seal Assy. FKM (viton type)	1(1 Per Pump)
4	17007	Sleeve Drive 7/8" for electric motor	1 (1 Per Pump)	18	17035SD	Severe Duty Seal	1(1 Per Pump)
5	*17008	Impeller – 5" (Standard)	1	19	17042	Stud	6
5	17008-4.6	Impeller – 4.6"(Trimmed) Elect. mtr.	1	20	17019	Capscrew 5/16" – 18 x 3/4"	8
5	17008-4.1	Impeller – 4.1"(Trimmed) Elect. mtr.	1	21	17009B	Nut, Hex 1/2" – 13 UNC	1
6	17010	Hex Nut 1/2" - 13UNF-RH	1	22	17130	C Sink Flat Head Screw	2
7	*17011	Wear Plate	1	N/S	17032	1/4" Drain Plug	1 (Not Shown)
8	17013	EPDM Gasket	1	N/S	17033	Z Rails	Pair
9	17016	Gasket-Check valve Assy.	1	N/S	17100	Pump Repair Kit (1 1/2" & 2") (Consists of items marked *)	1
10	*17018	Gasket Adapter	1				
11	15022	Handle	1				
12	17023	Clamp 5/8", 3/4" Shaft Assy.(Old Style)	(1 Per Pump)				
12	17123	Clamp 5/8", 3/4" Shaft Assy.(Keyed)	(1 Per Pump)				
12	17024	Clamp 7/8" Shaft Assy.	(1 Per Pump)				
13	17026	Pump Housing	1				
14	V10118	5/16" Lockwasher	18				
15	V10119	5/16" – 18 Hex Nut S.S.	6				

The Spray Tech part number can be derived by adding the prefix 'TE' to the listed Banjo part numbers.



2" Close Coupled C/I Electric Driven Pumps

FEATURES

- Cast iron construction for rugged dependable service.
- Stainless steel shaft sleeve to protect engine shaft.
- Carbon ceramic seal with stainless steel cup and spring with FKM (viton type) rubber.
- Replaceable inlet and outlet flanges.
- Dynamically balanced impeller.

CAUTION-WARNING: Please do not run pumps dry, restrict or reduce port sizes or dead head pumps. This could cause component failure to pump.

DO NOT USE WITH FLAMMABLE LIQUIDS.



2" CLOSE COUPLED ELECTRIC DRIVEN PUMP - CAST IRON

PART NO.	DESCRIPTION	SIZE	HP
234PIE5	2" CI Pump, 5 HP, 3450 RPM Motor, 3 Phase	2" x 2"	5
234PIE51	2" CI Pump, 5 HP, 3450 RPM Motor, Single Phase	2" x 2"	5
234PIE3	2" CI Pump, 3 HP, 3450 RPM Motor, 3 Phase	2" x 2"	3

NOTE: Truck shipments only. Motor warranty service available at authorized dealers.

COMPLETE PUMP WITH STANDARD-E (EFFICIENT) INDUSTRIAL ELECTRIC MOTORS!

MOTOR FEATURES:

- Pressure cast aluminum end plates with ribbed design for rigidity.
- Ball bearings, locked drive end bearing.
- Heavy gauge steel frame.
- Motors wound with inverter spike resistance magnet wire.
- Mounted complete on Heavy Duty Cast Iron Base Plate.
- 230 V Motors.

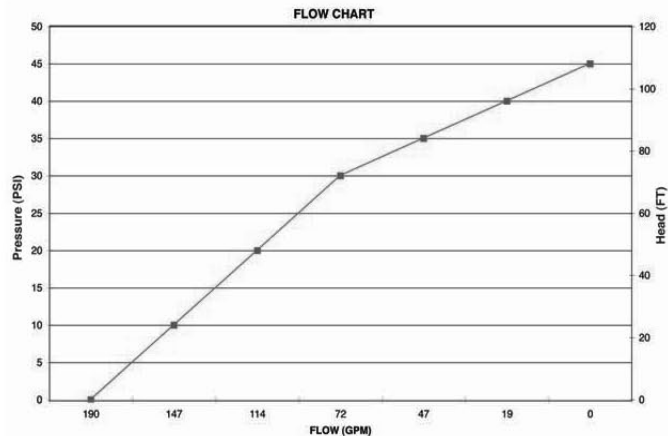

The Spray Tech part number can be derived by adding the prefix 'TE' to the listed Banjo part numbers.

BANJO PUMPS

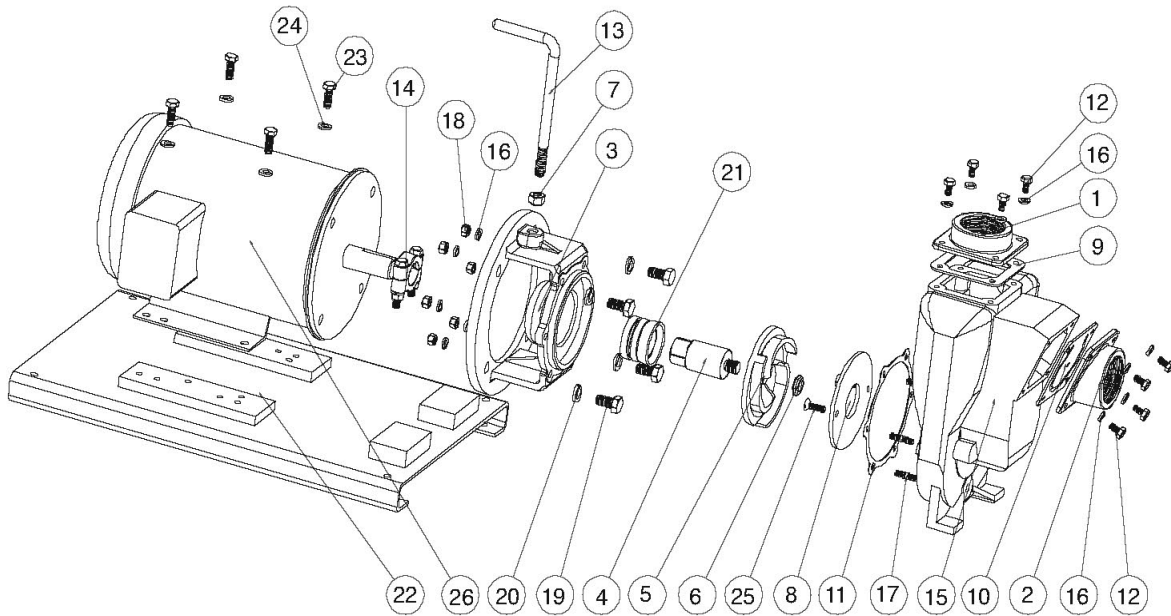

REPLACEMENT PARTS - 234PIE3 - 234PIE5 - 234PIE51						
REF. NO.	QTY	DESCRIPTION	234PIE3		234PIE5	234PIE51
1	1	Outlet Flange	17000		17000	17000
2	1	Inlet Flange	17002		17002	17002
3	1	C-Flange	17046		17446	17446
4	1	Impeller Shaft	17007		17406	17406
5	1	Impeller	17008		17408	17408
6	1	Impeller Nut	17009B		17009B	17009B
7	1	Hex Nut	17010		17010	17010
8	1	Wear Plate	17011		17011	17011
9	1	Outlet Gasket	17013		17013	17013
10	1	Gasket and Check Valve	17016		17016	17016
11	1	Adapter Gasket	17018		17018	17018
12	8	Bolt	17019		17019	17019
13	1	Handle	17022		17022	17022
14	1	Clamp Assembly w/Key	17024		18129	18129
15	1	Pump Housing	17026		17026	17026
16	20	Lockwasher	V10118		V10118	V10118
17	6	Housing Stud	17042		17042	17042
18	8	Hex Nut	V10119		V10119	V10119
19	4	Bolt	17449		17449	17449
20	4	Washer	18058		18058	18058
21	1	Seal	17035		18025	18025
22	1	Base Plate Assembly*	17700		17700	17700
23	4	Bolt	17704		17704	17704
24	4	3/8" Lockwasher	V20018		V20018	V20018
25	2	FLT HD Screw	17130		17130	17130
26	1	Electric Motor	BEM3		BEM5	BEM51

* Includes: Shims, Hardware, and Coupling Guard

The Spray Tech part number can be derived by adding the prefix 'TE' to the listed Banjo part numbers.



3" Gas Driven Cast Iron Self-Priming Centrifugal Pump

FEATURES

- Cast iron construction for rugged dependable service.
- Stainless steel shaft sleeve to protect engine shaft.
- Carbon ceramic seal with stainless steel cup and spring with FKM (viton type) rubber.
- Replaceable inlet and outlet flanges.
- Dynamically balanced impeller.

NOTE: Engine warranty service available at authorized Briggs & Stratton and Honda dealers.

SHIPPING: Truck shipments only.

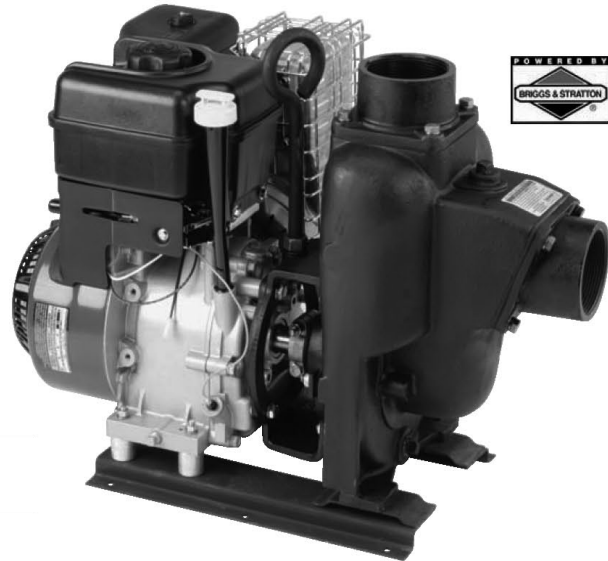

3" SELF PRIMING CENTRIFUGAL PUMP W/BRIGGS & STRATTON

PART NO.	DESCRIPTION	SIZE	HP
300PI8PRO*	3"x3" Cast Iron Pump x 8 HP Briggs Intek Pro	3" x 3"	8

NOTE: Pull rope only, no electric start available.

CAUTION-WARNING: Please do not run pumps dry, restrict or reduce port sizes or dead head pumps. This could cause component failure to pump.

DO NOT USE WITH FLAMMABLE LIQUIDS.

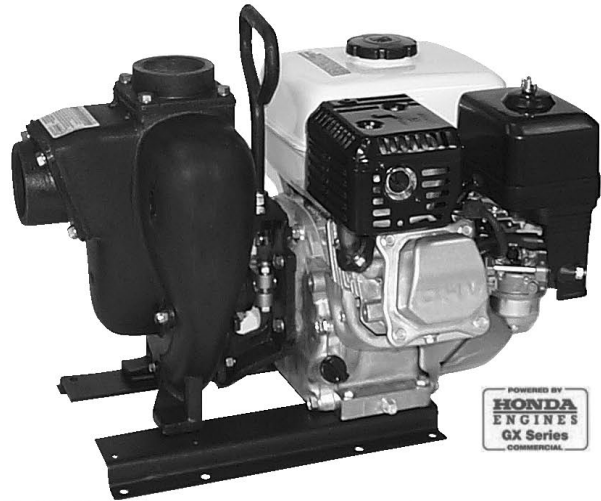

3" SELF PRIMING CENTRIFUGAL PUMPS W/HONDA ENGINE

PART NO.	DESCRIPTION	SIZE	HP
300PIH-8*	3" x 3" Cast Iron Pump x 8 H.P. Honda Engine – Electric Start w/ pull rope	3" x 3"	8
300PIH-11*	3" x 3" Cast Iron Pump x 11 H.P. Honda Engine – Electric Start w/ pull rope	3" x 3"	11
300PIH13*	3" x 3" Cast Iron Pump x 13 H.P. Honda Engine – Electric Start w/ pull rope	3" x 3"	13

FLOW CHART

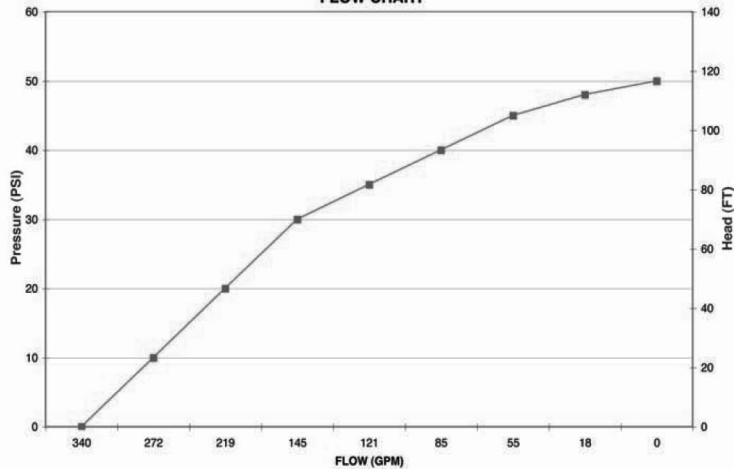

The Spray Tech part number can be derived by adding the prefix 'TE' to the listed Banjo part numbers.

BANJO PUMPS

3" CAST IRON PUMP

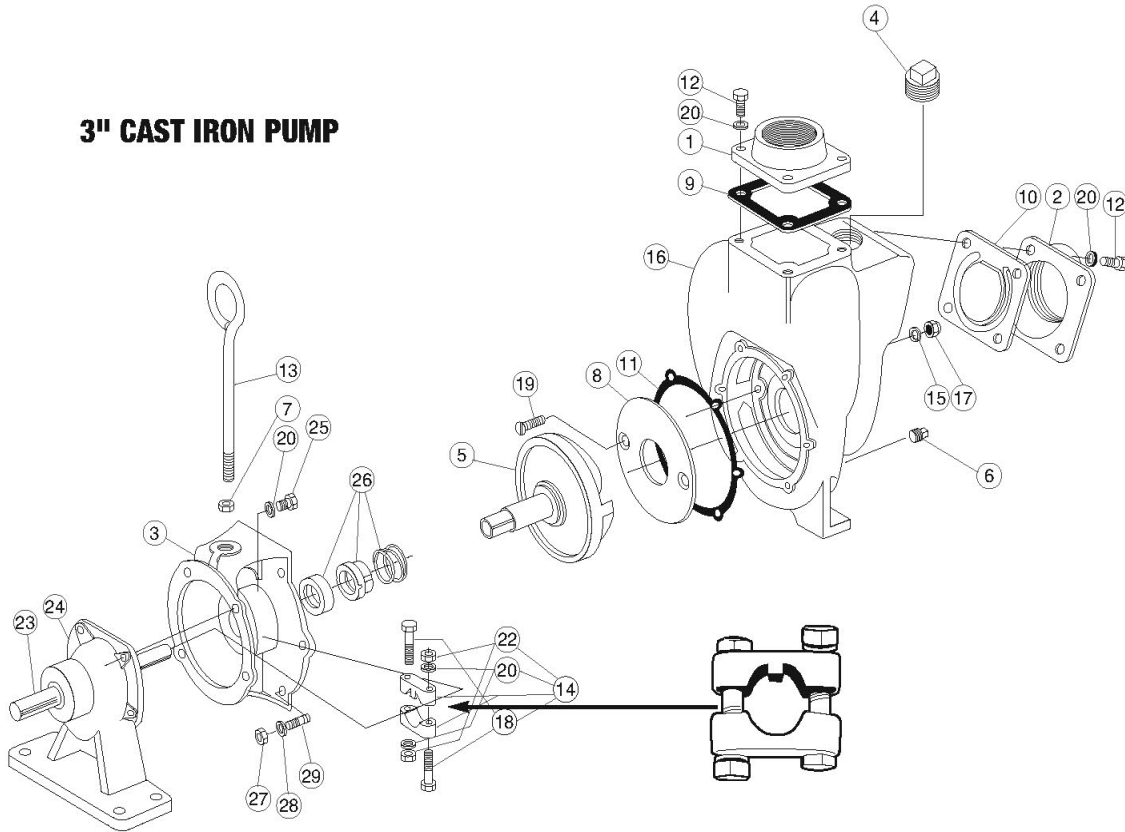

REPLACEMENT PARTS 3" CAST IRON PUMPS

REF. NO.	PART NO.	DESCRIPTION	QTY. PER PUMP	REF. NO.	PART NO.	DESCRIPTION	QTY. PER PUMP
1	18008	Flange, Outlet 3" NPT	1	15	18005*	Gasket, Wear Plate	2
2	18012	Flange Inlet 3" NPT	1	16	18001	3" Pump Housing	1
3	18026	Gas Engine Adapter	1	17	18007	$\frac{3}{8}$ " - 16 SS Acorn Nut	2
3	18048	3" C-Flange Adapter	1	18	18030	Bolt $\frac{3}{8}$ " - 24 x 2 $\frac{1}{4}$ " Large	2
3	18049	C.I. Hydraulic Motor Adapter 3"	1	19	18106*	Flat Head Wear Plate Screw	2
N/S	18055	Hydraulic Adapter Shaft 3"	1	20	V20018	Lock Washer $\frac{3}{8}$ "	8
4	18002	Plug 1" NPT Flush	1	22	18032	Nut $\frac{3}{8}$ " x 24 Hex SS	2
5	18023*	Impeller&Drive Shaft 1" (Gas Engine)	1	23	18504	1" Shaft For 3" Pedestal.	1
5	18023-1125	Impeller&Drive Shaft 1 $\frac{1}{8}$ " (Elec.Motor)	1	24	18500	3" Bearing Pedestal - Complete	1
6	18003	Plug $\frac{1}{2}$ " NPT	1	N/S	18502	Bearing	2
7	18034	Nut, Jam $\frac{5}{8}$ " - 11 Thread. SS	1	25	17704	Bolt	4
8	18004*	Wear Plate	1	28	18025*	Seal Assy. FKM (viton type)	1
9	18009	Gasket, Outlet EPDM	1	26	18025SD	Severe Duty Seal	1
10	18013	Gasket Check Valve Assy.	1	27	V20019	Nut $\frac{3}{8}$ " - 24, Hex SS	6
11	18021*	Gasket, Adapter	1	28	V20018	Washer $\frac{3}{8}$ " Lock SS	6
12	18010SS	Capscrew HXHD $\frac{3}{8}$ "-16x1 $\frac{1}{8}$ "LG SS	8	29	18218	Stud $\frac{3}{8}$ "-16 x $\frac{3}{8}$ "-24 x 1 $\frac{1}{2}$ "LG SS	6
13	18033	Handle $\frac{5}{8}$ " - 11 Thread.	1	N/S	18035	Z-Rail Mtg. Bracket.	1 Pr.
14	18029	Clamp Assy. SS (Old Style)	1 Assy.	N/S	18100	3" Pump Repair Kit (Consists of items marked *)	1
14	18129	Clamp Assy. SS (Keyed)	1 Assy.				

The Spray Tech part number can be derived by adding the prefix 'TE' to the listed Banjo part numbers.

BANJO®

3" Cast Iron Pumps

PUMP ONLY FEATURES

- Pump only packs complete and ready for attachment to gasoline engine.



IMPORTANT

- Recommended horsepower, listed below, is for water only. 10 HP motor is recommended for fluids heavier than water.

3" CAST IRON PUMP ONLY				
PART NO.	DESCRIPTION	SIZE	HP	
300POI*	3" x 3" Cast Iron Pump Only 1" shaft	3" x 3"	N/A	

*Truck Shipments Only

3" CAST IRON C-FLANGE PUMPS				
PART NO.	DESCRIPTION	SIZE	HP	
300POICF*	3" Cast Iron Pump ONLY with 1 1/8" Shaft Sleeve (7 1/2 HP, 3450 RPM, 184TC Frame Size Recommended)	3" x 3"	N/A	

*Truck Shipments Only

CAUTION-WARNING: Please do not run pumps dry, restrict or reduce port sizes or dead head pumps. This could cause component failure to pump.

DO NOT USE WITH FLAMMABLE LIQUIDS.

3" Pedestal Pumps

FEATURES

- With the addition of the Banjo bearing pedestal the pump is easily adaptable to an electric motor.
- Flexible coupling not included.
- 1" Straight keyed shaft.



3" CAST IRON PEDESTAL PUMP				
PART NO.	DESCRIPTION	SIZE	HP	
300PBI*	3" x 3" C.I. Pump With Pedestal	3" x 3"	N/A	

*Truck Shipments Only



The Spray Tech part number can be derived by adding the prefix 'TE' to the listed Banjo part numbers.

BANJO PUMPS

3" CAST IRON PUMP

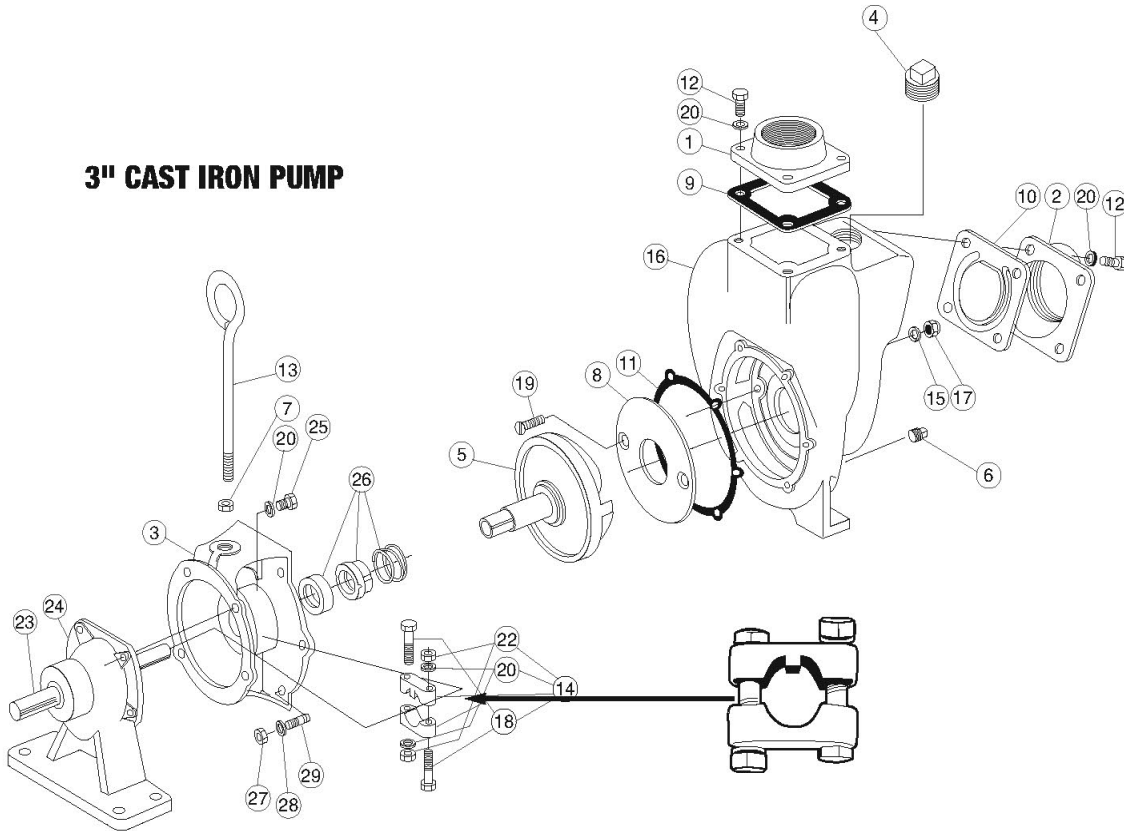

REPLACEMENT PARTS 3" CAST IRON PUMPS

REF. NO.	PART NO.	DESCRIPTION	QTY. PER PUMP	REF. NO.	PART NO.	DESCRIPTION	QTY. PER PUMP
1	18008	Flange, Outlet 3" NPT	1	15	*18005	Gasket, Wear Plate	2
2	18012	Flange Inlet 3" NPT	1	16	18001	3" Pump Housing	1
3	18026	Gas Engine Adapter	1	17	18007	$\frac{3}{8}$ " - 16 SS Acorn Nut	2
3	18048	3" C-Flange Adapter	1	18	18030	Bolt $\frac{3}{8}$ " - 24 x 2 $\frac{1}{4}$ " Large	2
3	18049	C.I. Hydraulic Motor Adapter 3"	1	19	18106*	Flat Head Wear Plate Screw	2
N/S	18055	Hydraulic Adapter Shaft 3"	1	20	V20018	Lock Washer $\frac{3}{8}$ "	8
4	18002	Plug 1" NPT Flush	1	22	18032	Nut $\frac{3}{8}$ " x 24 Hex SS	2
5	18023*	Impeller&Drive Shaft 1" (Gas Engine)	1	23	18504	1" Shaft For 3" Pedestal	1
5	18023-1125	Impeller&Drive Shaft 1 $\frac{1}{8}$ "(Elec.Motor)	1	24	18500	3" Bearing Pedestal - Complete	1
6	18003	Plug $\frac{1}{2}$ " NPT	1	N/S	18502	Bearing	2
7	18034	Nut, Jam $\frac{5}{8}$ " - 11 Thread. SS	1	25	17704	Bolt	4
8	18004*	Wear Plate	1	26	18025*	Seal Assy. FKM (viton type)	1
9	18009	Gasket, Outlet EPDM	1	26	18025SD	Severe Duty Seal	1
10	18013	Gasket Check Valve Assy.	1	27	V20019	Nut $\frac{3}{8}$ " - 24, Hex SS	6
11	18021*	Gasket, Adapter	1	28	V20018	Washer $\frac{3}{8}$ " Lock SS	6
12	18010SS	Capscrew HXHD $\frac{3}{8}$ "-16x1 $\frac{1}{8}$ "LG SS	8	29	18218	Stud $\frac{3}{8}$ "-16 x $\frac{3}{8}$ "-24x 1 $\frac{1}{2}$ "LG SS	6
13	18033	Handle $\frac{5}{8}$ " - 11 Thread.	1	N/S	18035	Z-Rail Mtg. Bracket.	1 Pr.
14	18029	Clamp Assy. SS (Old Style)	1 Assy.	N/S	18100	3" Pump Repair Kit (Consists of items marked *)	1
14	18129	Clamp Assy. SS (Keyed)	1 Assy.				

The Spray Tech part number can be derived by adding the prefix 'TE' to the listed Banjo part numbers.

12-Volt / ATV / Small Sprayer Pumps



PowerFLO™ 5800/5900 Series

12 Volt DC Motor-Driven
Diaphragm Pumps



5000 Series Powerflo Pumps	
Part No.	Description
DE5950-101	5 Chamber Demand pump, 5.3 gpm, 60 psi
DE5950-104E	(115 Volt) 5.0 gpm, 60 psi

PowerFLO™ 5800/5900 Series

Installation Recommendations

Mounting:

Determine the optimum location for your pump.

1. The pump should be mounted in a dry place and away from any source of heat. If an enclosure is used, special instructions for cooling the motor may be necessary. Consult the Factory.
2. Do not subject the pump to extreme high or low (freezing) temperatures while in operation. (Operating ambient temperature range is 32° F to 115°F).
3. The pump may be mounted horizontally with the outlet port on the right when viewed from the pump end or with the pump above the mount, or vertically with the pump above or below the motor.

Plumbing:

1. Use suction hose on inlet of pump. We recommend use of flexible tubing with proper pressure rating.
2. Pump will prime only if all pressure is relieved from outlet port.
3. It is recommended that pure water be pumped or an in-line sediment filter (50 mesh) be installed at the inlet side to keep foreign debris out of the system. If a check valve is installed in the plumbing, it must have a cracking pressure of no more than 2 psi (0.14 bar).
4. Avoid any sharp bends which may crimp tubing and restrict flow. Use 90° elbow fittings if necessary.
5. The pump should always be mounted prior to any components which could introduce particles to the water; thus, preventing them from entering the pump chambers and possibly causing clogging.

Electrical:

1. The 5800/5900 series pumps are designed for intermittent duty. Make sure that "OFF" periods are sufficient. Refer to Rapid ON/OFF Operation. Consult the factory for particular data and design criteria.
2. Be sure power supply used is adequate for the application.
3. Pump and motor specifications are based on an alternator charged battery (12 VDC)
4. Use sufficient battery supply power. Smaller ATV and lawn tractor batteries may affect pump performance due to low voltage and amp ratings.

Installation and Operation Precautions:

1. The pump is equipped with a pressure sensing demand switch that controls the maximum operating pressure.
2. In addition, never subject the pump to pressures above 125 PSI (8.5 bars).
3. As long as there is inlet water pressure, the pump will not stop forward flow of water even if the motor is turned off. Be sure the system has positive means of shutting off water supply.
4. Do not operate pump in an explosive environment. Arcing from the motor brushes, switch or excessive heat from an improperly cycled motor may cause an explosion.
5. Do not locate the pump motor near low temperature plastics or combustible material. The surface temperature of the motor may exceed 250°F (120°C).
6. Do not pump gasoline or other flammable liquids. Pump head materials are designed for use with water only. Do not use with petroleum products.
7. Do not assume fluid compatibility. If the fluid is improperly matched to the pumps' elastomers, a leak may occur.
8. To prevent electrical shock, disconnect power before initiating any work. In the case of pump failure, the motor housing and/or pump fluid may carry high voltage to components normally considered safe. Therefore, always consider electrical shock hazard when working with and handling electrical equipment. If uncertain, consult an Electrician. Electrical wiring should only be done by a qualified electrician per local and state electrical codes.

Installation and Operation

1. Turn off water supply.
2. Cut flexible tubing in sufficient length to avoid any stress on the tubing where it connects to the pump or the fitting on any accessory.
3. Insert tubing into pump ports. If fittings are John Guest type, be sure tubing is inserted past the resistance point until it bottoms out against the port stop. If compression fittings with threaded nuts are used, insert tubing until it bottoms out in the port and hand tighten the compression nut until the connection is tight. Then use a wrench to tighten the nut 1/2 turn clockwise or follow the wrench tightening instructions provided by the fitting manufacturer.
4. The pump is now ready for operation. Turn on water supply to allow water to flow to the pump.
5. If the power source is a transformer, plug the appropriate supplied/approved transformer into the receptacle and connect the pump to the transformer. If the power source is not a transformer, connect the pump to the appropriate power source. Open the discharge or dispensing valve. Allow water to circulate, purging any entrapped air.
6. The pump will now start building pressure. Operating pressure will vary with flow rate, flow valve, feed-water pressure and line voltage. Check for fitting leaks.
7. If compression fittings with threaded nuts are used, observe any leaks after pump has run for approximately 15 minutes. Further tighten compression nuts approximately 1/8 to 1/4 of a turn on all fittings in the system. Wait 15 minutes and repeat the leak check. Note: Further adjustments should not be necessary although it may take several days of operation before all the air has been purged and the system is stabilized.
8. Adjusting the Pressure Switch. Should the pressure switch OFF setting vary with use and time to an unsuitable value, it may be adjusted for optimum performance. Turn the setscrew clockwise to increase the OFF pressure setting and counter clockwise to decrease. The screw should not be adjusted more than one half turn without consulting the Factory. Excessive adjustment of the pressure switch could cause low system pressure, rapid cycling ON/OFF operation, and reduced pump and motor life. Damage may occur. The Warranty does not cover improper adjustment of the pressure switch.
9. Rapid ON/OFF Operation. In response to the characteristics of the system in which the pump is installed, the flexibility and length of the tubing, the faucet or valves, and the duration they are open; the time between pump ON and OFF may vary. Cycling operation of less than one minute OFF for each 30 seconds ON is considered to be an excessive duty cycle. In such cases the pressure switch may require adjustment. If the OFF period continues to be less than one minute the Factory should be consulted. It is good practice to allow the pump to be OFF for 3 minutes after every 30 seconds ON. For each minute of continuous running or cycling operation it is good practice to allow a 10 minute rest period to cool the motor.

Servicing:

Every Year: Check system against operating standards.

Every 2-3 Years: We recommend replacing the diaphragm and checking against operating standards.

PowerFLO™ 5800/5900 Series

Pressure Sensing Demand Switch



The PowerFLO Series 5800/5900 pump is controlled by a built-in pressure sensing demand switch. When a faucet or valve is opened down stream of the pump, line pressure drops thus starting the pump automatically. Conversely, when the valve shuts, the line pressure increases turning the pump off automatically. The pressure switch actuates in response to the pump outlet pressure at a predetermined and preset pressure. The pump label indicates the predetermined ON and OFF pressures. Typically, the OFF pressure is accurately set at the Factory and the ON pressure is within an allowable range below that value. In response to the characteristics of the system in which the pump is installed, the flexibility and length of the tubing, the faucet or valves and the duration that they are open; these pressure settings may vary. Therefore, variation in pressure setting is expected with use and over time.

Troubleshooting Guide

Problem/Causes and Remedies

Pump will not Start

Check:

- Correct voltage ($\pm 10\%$) and electrical connections (see page 4 electrical installation recommendations)
- Fuse or breaker
- Pressure switch operation and correct voltage at switch
- Rectifier or motor for open or grounded circuit
- Locked drive assembly

Pump will not Prime (No discharge with motor running)

Check:

- Debris in strainer
- Restriction (kinks) in inlet/outlet tubes
- Debris or swelling in inlet/outlet valves

Pump will not Shut Off (Output line closed and no leaks)

Check:

- Air trapped in outlet line or pump head
- Correct voltage to pump
- Debris in pump inlet/outlet valves
- Loose drive assembly or pump head screws
- Pressure switch operations/adjustments

Leaks from Pump Head or Switch

Check:

- Loose screws at switch or pump head
- Switch diaphragm ruptured or pinched
- Punctured diaphragm if fluid is present

12 Volt DC Motor-Driven Diaphragm Pumps



Replacement Parts

PowerFlow Models 5800/5900

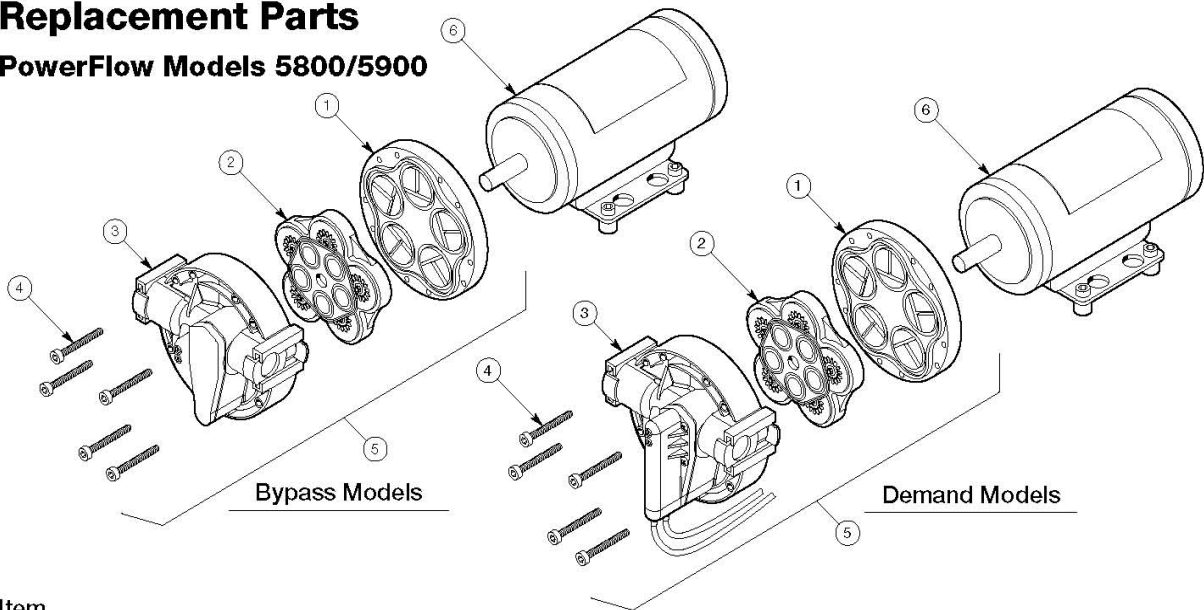

Item #	Description	Part Number	Qty
1	Lower Housing		1
	5830/5836 - 5930/5936 – Demand or Bypass	LHA5510-1E77	
	5840/5940 – Demand or Bypass	LHA5512-1E77	
	5850/5950 – Demand or Bypass	LHA5513-1E77	
2	Valve Assembly		1
	5800/5900 Series Pumps	VHA-5513-1E77	
3	Upper Housing		1
	5800 w/Pressure Switch	UHA-5513-1E77	
	5800 w/Bypass	UHA-5513-2E77	
	5900 w/Pressure Switch	UHA-5503-1E77	
	5900 w/Bypass	UHA-5503-2E77	
4	Mounting Bolts	MB-5500-1	4
5	Complete Pump Head w/Threaded Ports		1
	5830/5836 w/Pressure Switch	5510-1X77	
	5830/5836 w/Bypass	5510-2X77	
	5840 w/Pressure Switch	5512-1X77	
	5840 w/Bypass	5512-2X77	
	5850 w/Pressure Switch	5513-1X77	
	5850 w/Bypass	5513-2X77	
	Complete Pump Head w/Quick Attach Ports		1
	5930/5936 w/Pressure Switch	5500-1X77	
	5930/5936 w/Bypass	5500-2X77	
	5940 w/Pressure Switch	5502-1X77	
	5940 w/Bypass	5502-2X77	
	5950 w/Pressure Switch	5503-1X77	
	5950 w/Bypass	5503-2X77	

Demand model Pressure SwitchDE5000PSW

Call Spray Tech to convert the above Delavan part numbers for your order.

PowerFLO™ 7800 Series

12 Volt DC Motor-Driven
Diaphragm Pumps



7800 Series Powerflo Pumps	
Part No.	Description
DE7801301	3 Chamber demand pump, 1 gpm, 60 psi

12 Volt DC Motor-Driven Diaphragm Pumps



Replacement Parts

PowerFLO Models 7801/7811 & 7802/7812

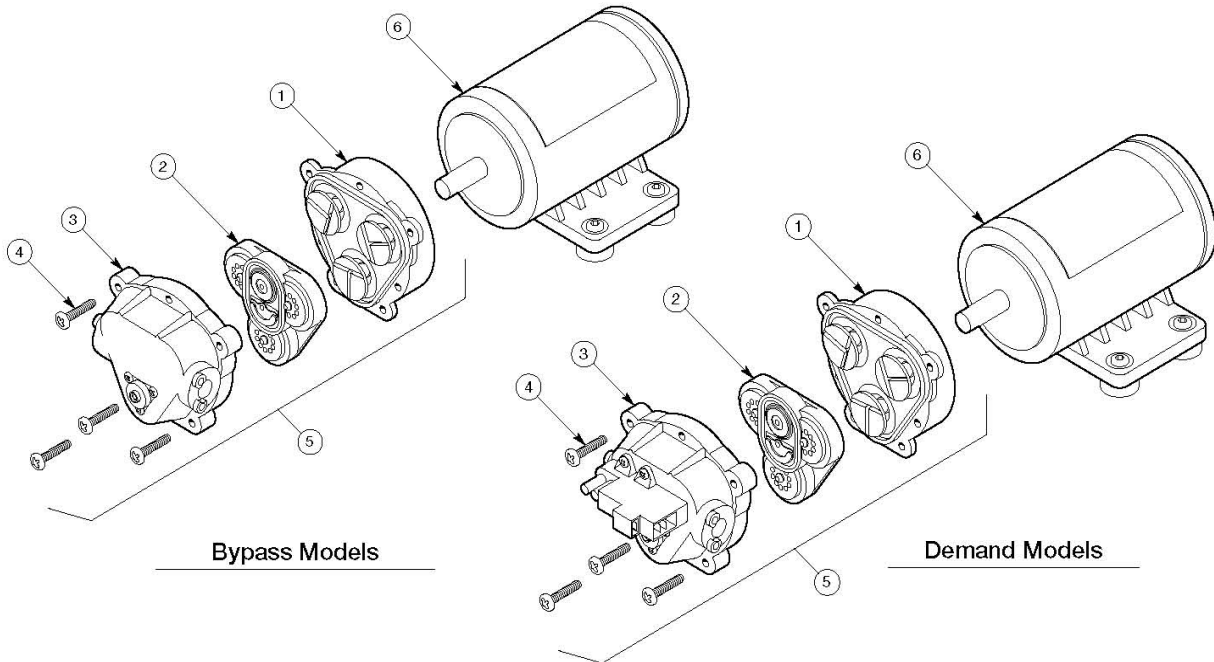

Item #	Description	Part Number	Qty
1	Lower Housing		1
	7801/7811 Demand or Bypass	LHA-7860-7F77	
	7802/7812 Demand or Bypass	LHA-7863-7F77	
2	Valve Assembly		1
	7800 Series (all models)	VHA-7863-7F77	
3	Upper Housing		1
	7801/7802 Series w/Pressure Switch	DE7800PSH	
	7801/7802 Series w/Bypass	UHA-7863-8I77	
	7811/7812 Series w/Pressure Switch	UHA-7863-7F77-T	
	7811/7812 Series w/Bypass	UHA-7863-8I77-T	
4	Mounting Bolts	MB-7863-1	4
5	Complete Pump Head w/Threaded Ports		1
	7811 w/Pressure Switch	PH-7811-D	
	7811 w/Bypass	PH-7811-B	
	7812 w/Pressure Switch	PH-7812-D	
	7812 w/Bypass	PH-7812-B	
	Complete Pump Head w/Quick Attach Ports		1
	7801 w/Pressure Switch	PH-7801-D	
	7801 w/Bypass	PH-7801-B	
	7802 w/Pressure Switch	PH-7802-D	
	7802 w/Bypass	PH-7802-B	

Call Spray Tech to convert the above Delavan part numbers (that do not begin with DE) for your order.

PowerFLO™ Diaphragm Pump Accessories

PowerFit™ Quick Attach Inlet/Outlet Fittings



3/8" straight hose barb x
Quick Attach. Nylon
For 7800 Pumps:
Set of Two: PK-3DFA38
Single Fitting : 3DFA38
For 5900 Pumps:
Set of Two: PK-5DFA38
Single Fitting : 5DFA38



3/8" FNPT x Quick Attach
Black Nylon
For 7800 Pumps:
Set of Two: PK-3DFF38
Single Fitting : 3DFF38



3/8" elbow hose barb x
Quick Attach. Nylon
For 7800 Pumps:
Set of Two: PK-3DFE38
Single Fitting : 3DFE38
For 5900 Pumps:
Set of Two: PK-5DFE38
Single Fitting : 5DFE38



1/2" FNPT x Quick Attach
Black Nylon
For 7800 Pumps:
Set of Two: PK-3DFF12
Single Fitting : 3DFF12



1/2" straight hose barb x
Quick Attach. Nylon
For 7800 Pumps:
Set of Two: PK-3DFA12
Single Fitting : 3DFA12
For 5900 Pumps:
Set of Two: PK-5DFA12
Single Fitting : 5DFA12

Spray Tech currently sells Delavan Quick attach fittings in **sets of two only**. Please use the prefix **'DE'** in front of the listed Delavan numbers.



1/2" elbow hose barb x
Quick Attach. Nylon
For 7800 Pumps:
Set of Two: PK-3DFE12
Single Fitting : 3DFE12
For 5900 Pumps:
Set of Two: PK-5DFE12
Single Fitting : 5DFE12

FLOJET 3000 SERIES PUMPS

Flojet's New Three Chamber Pump For Spraying, Dispensing and Transfer Applications



BIG Performance in a **small Package**

Introducing the Flojet 3000 Series Pump* up to 60 PSI

Flojet, the recognized leader in small pump design, has introduced an all new three chamber pump. Although the pump was designed specifically for sprayers, its versatile features enable it to work well in many other transfer or dispensing applications. Of course, it comes equipped with the quality and features you have come to expect from Flojet.

*Patent Pending

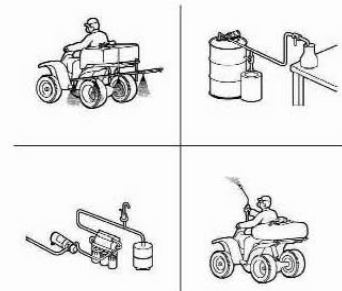

FLOJET®

FLOJET 3000 SERIES PUMPS

APPLICATIONS

- Small Boom and Spot Spraying
- Foam Marking
- Silage Treatment
- Estate Spraying
- Livestock and Poultry Cooling
- Dispensing
- Transfer of liquids

FEATURES

- Compact automatic demand pump
- Sealed pressure switch and motor
- Self-priming; pump can be located above supply tank
- Can run dry for extended periods of time without damage
- Flow rates to 2.0 GPM (7.6 l/min) and operating pressure to 50 psi (3.4 bar)

DIMENSIONS

115 VAC

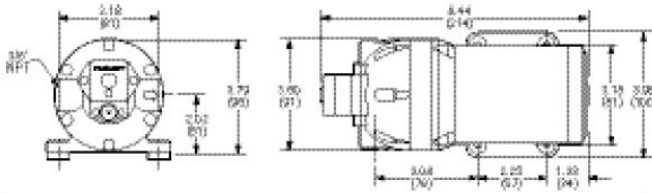

12 VDC

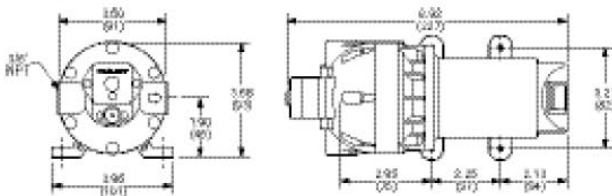

SPECIFICATIONS

Flow Rate:	2.0 GPM (7.8 l/min) max.
Pump Design:	Three Chamber
Motor:	Permanent magnet TENV (non-ventilated)
Voltage:	12 VDC, 115 VAC, 230 VAC
Current:	8 amp max.
Pressure Switch Setting:	30-60 psi (2.0-4.1 bar)
Maximum Operating Pressure:	50 psi (3.4 bar)
Maximum Fluid Temperature:	130° F (54° C)
Self Priming:	Up to 6 ft (2.4m) vertical height
Ports:	3/8" NPTF
Wetted Parts: Housing – Reinforced Polypropylene Elastomers – Santoprene®, Viton®	
Net Weight:	3.4 lbs (1.5 kg)

® A Registered trademark of E.I. duPont and Monsanto Co.

PUMP PERFORMANCE

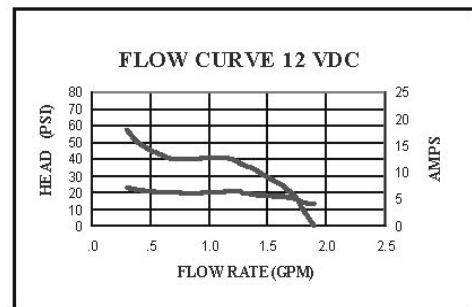
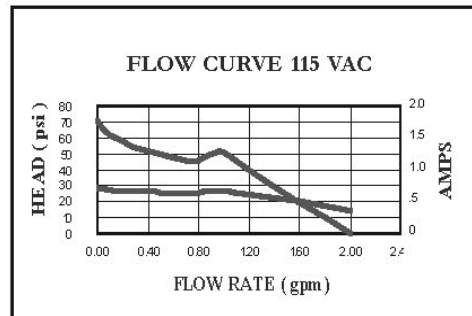

Call Spray Tech for price, availability, and part numbers for the Flojet 3000 Series.

Diesel-Compatible Pump

Flojet model D2132I5011A: 1.6 gpm, 60 psi, Buna diaphragm, Viton check valve. Suitable for spraying diesel, particularly for cotton module truck applications. Call Spray Tech for price and availability.

QUAD PUMP



-
- Flojet 4000 Delivers Flows up to 5.0 GPM
 - Built-in Pressure Switch Automatically Starts and Stops Pump Instantaneously
 - Can Run Dry Without Damage
 - Excellent Self-priming Capability
 - Powerful Magnet Motor with Low Current Draw
 - Plug-in Ports for Easy Installation
-

FLOJET

SPECIAL FEATURES

FLOJET 4000 delivers up to 40 PSI (2.8 bar) working pressure. Built-in pressure switch automatically starts and stops pump instantaneously when discharge valve is opened and closed. Compact design and plug-in port fittings make installation easy. Can run dry without damage and handle liquids up to 130°F (54°C). Quad Diaphragm Design eliminates troublesome shaft seal. No metal contact with liquid being pumped. Ball bearing drive throughout pump and motor assures longer pump life. Excellent self-priming capability. Pump may be located above the liquid level. Powerful, permanent magnet motor with low current draw and long life brushes.

PUMP PERFORMANCE

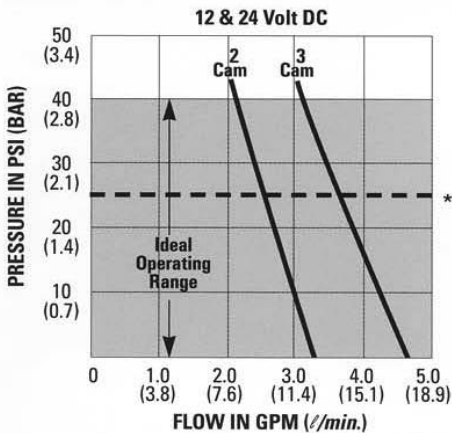

* Continuous Duty Max Pressure For No Switch 3 Cam Models.

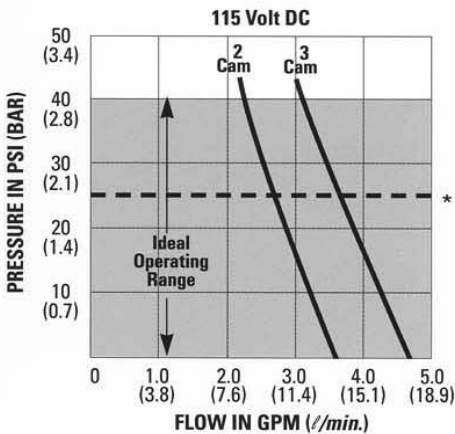

* Continuous Duty Max Pressure For No Switch 3 Cam Models.

SPECIFICATIONS

Flow Rate	3.5 to 5.0 GPM (13.2 and 18.9 <i>l/min.</i>)	Nominal
Pump Design	Diaphragm	
Shaft Seal	None	
Motor	Permanent Magnet Motor	
Standard	TEFC (fan-cooled)	
Voltage	12 & 24 Volt DC, 115 & 230 Volt AC	
Cycle	50/60 hertz for AC Models	
Current		
12 Volt	14.0 amp max.	
24 Volt	0.7 amp max.	
115 Volt	1.5 amp max.	
230 Volt	0.75 amp max.	
Pressure Switch Setting	45 PSI (3.2 bar) cut out	
	30 PSI (2.1 bar) cut in	
Maximum Operating Pressure	40 PSI (2.8 bar)	(Demand Pumps only)
Maximum Fluid Temperature	130°F (54°C)	
Self-Priming	Up to 8 ft. (2.4 m) Vertical Height	
Ports	Plug-In Ports 1/2" or 3/4" Hose Barb Standard (Consult Factory for other type of Port Fittings)	
Wetted Parts		
Housing	Modified Polypropylene - Standard	
Elastomers	Santoprene® and Buna - Standard	
Net Weight	4 lbs. (2 kg)	

® A Registered trademark of E.I. duPont de Nemours & Co. Inc.

Spray Tech sells these 4300 Models:

Part Number	Description
FL4300-500	12V, 5 gpm, 45 psi
FL4300-501A	115V, 5 gpm, 45 psi

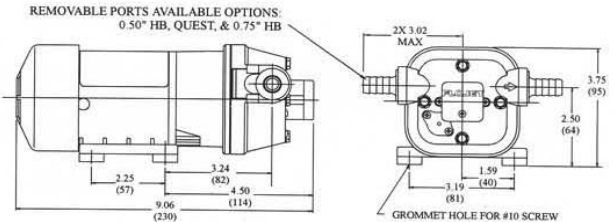

DUPLEX DIAPHRAGM DEMAND PUMP

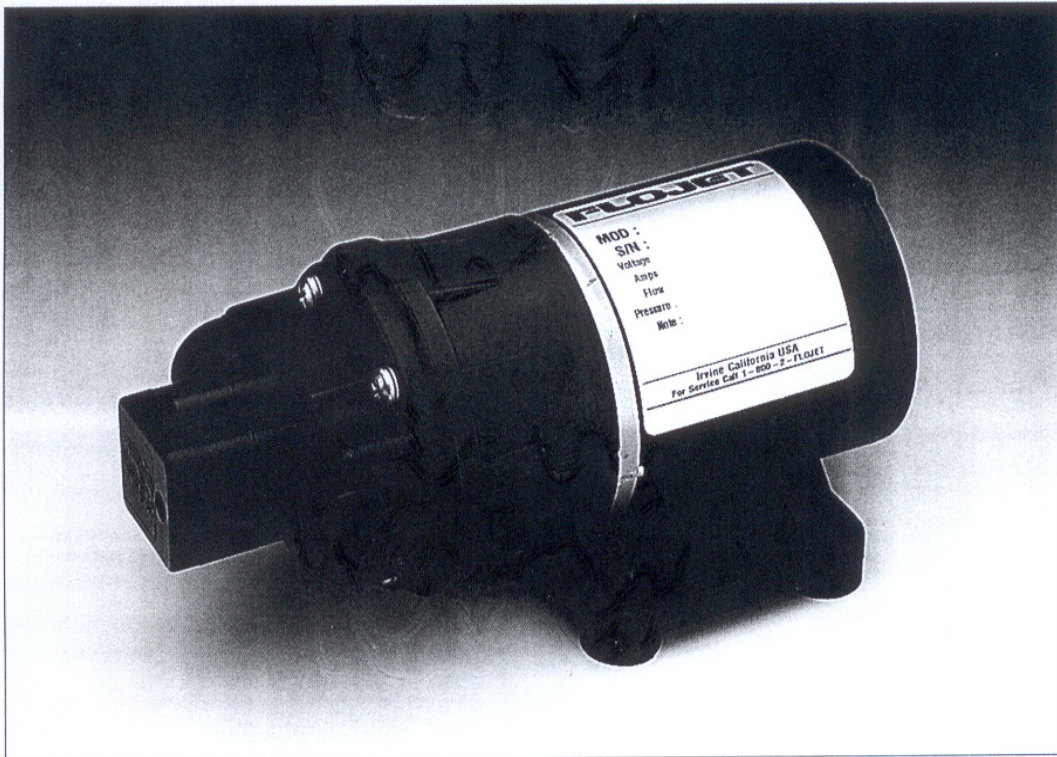

-
- Flojet 2100 Delivers Flows up to 2.0 GPM and Operating Pressures up to 50 PSI
 - Built-in Pressure Switch Automatically Starts and Stops Pump Instantaneously
 - Can Run Dry Without Damage
 - Excellent Self-Priming Capability
 - Powerful Permanent Magnet Motor with Low Current Draw
-

FLOJET

FLOJET 2100 SERIES

DUPLEX DIAPHRAGM DEMAND PUMP

SPECIAL FEATURES

FLOJET 2100 delivers up to 54 PSI (3.5 bar) working pressure. See model 2130 or 2135 for applications up to 100 PSI (6.9 bar). Built-in pressure switch automatically starts and stops pump instantaneously when discharge valve is opened and closed. Can run dry without damage and handle liquids up to 160°F (71°C).

Duplex Diaphragm Design eliminates troublesome shaft seal. No metal contact with liquid being pumped.

Ball bearing drive throughout pump and motor assures longer pump life.

Excellent self-priming capability. Pump may be located above the liquid level.

Powerful, permanent magnet motor with low current draw and long life brushes.

U.L. recognized (115 Volt AC only).

Available in 12 to 230 Volts.

PUMP PERFORMANCE

CAPACITY, Gallons Per Minute (Liters/Minute)

115 & 230 Volt						
Model No.	Max. Flow	10 psi (.7 bar)	20 psi (1.4 bar)	30 psi (2.1 bar)	40 psi (2.8 bar)	50 psi (3.5 bar)
2100-030 (2100-230)	1.65 (6.3)	1.38 (5.2)	1.16 (4.4)	1.0 (3.8)	.89 (3.3)	.79 (3.0)
2100-031 (2100-231)	1.35 (5.1)	1.06 (4.0)	.91 (3.4)	.78 (2.9)	.68 (2.6)	.62 (2.3)
2100-032 (2100-232)	1.85 (7.0)	1.51 (5.7)	1.34 (5.0)	1.19 (4.5)	1.05 (4.0)	.94 (3.6)
2100-034* (2100-234)	1.01 (3.8)	.81 (3.0)	.68 (2.5)	.58 (2.2)	.49 (1.8)	.41 (1.5)
2100-035 (2100-235)	1.94 (7.3)	1.75 (6.6)	1.55 (5.8)	1.37 (5.1)	1.23 (4.6)	1.13 (4.3)
12 & 24 Volt						
Model No.	Max. Flow	10 psi (.7 bar)	20 psi (1.4 bar)	30 psi (2.1 bar)	40 psi (2.8 bar)	50 psi (3.5 bar)
2100-130 (2100-330)	1.87 (7.0)	1.53 (5.8)	1.43 (5.4)	1.27 (4.8)	1.15 (4.3)	1.03 (3.9)
2100-131 (2100-331)	1.66 (6.2)	1.45 (5.5)	1.24 (4.6)	1.10 (4.1)	.98 (3.7)	.87 (3.3)
2100-132 (2100-332)	2.15 (8.1)	1.90 (7.2)	1.70 (6.4)	1.64 (6.2)	1.50 (5.7)	1.39 (5.2)
2100-134* (2100-334)	1.15 (5.8)	.97 (3.6)	.86 (3.2)	.74 (2.8)	.67 (2.5)	.57 (2.1)
2100-135 (2100-335)	2.35 (8.9)	2.10 (7.9)	1.95 (7.3)	1.80 (6.8)	1.65 (6.3)	1.53 (5.8)

SPECIFICATIONS

Flow Rate	1.0 to 2.0 GPM (3.7 to 7.6 L/min) Nominal
Pump Design	Duplex Diaphragm
Shaft Seal	None
Motor	Permanent Magnet Motor
Standard	TE _N V (non-ventilated)
Optional	TEFC (fan-cooled)
Voltage	12 & 24 Volt DC, 115 & 230 Volt AC
Cycle	50/60 hertz for AC Models
Current	
12 Volt	8.0 amp max.
24 Volt	3.5 amp max.
115 Volt	0.55 amp max.
230 Volt	0.25 amp max.
Pressure Switch Setting	40 - 60 PSI (2.1 - 4.2 bar)
Maximum Operating Pressure	50 PSI (3.5 bar)
Maximum Fluid Temperature	160°F (71°C)
Self-Priming	Up to 8 ft. (2.4 m) Vertical Height
Ports	3/8" NPT, May be rotated in 90° increments
Wetted Parts	
Housing	Reinforced Polypropylene - Standard Nylon - Optional
Elastomers	Santoprene® - Standard Viton® and Buna - Optional
Net Weight	3.8 lbs. (1.7 kg)

® A Registered trademark of E.I. duPont de Nemours & Co. Inc.

Spray Tech sells these 2100 Models:

Part Number	Description
FL2100-122	12V, 60 psi switch, viton
FL2100-132	12V, 60 psi switch, santo

DIMENSIONS (Inches/mm)

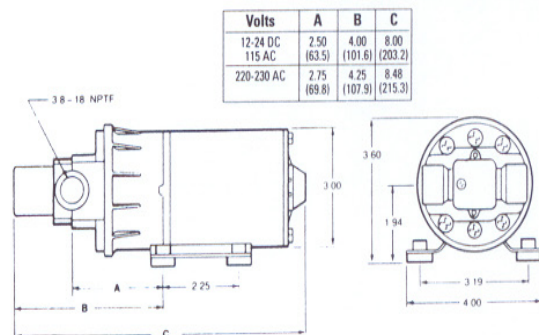

PUMP INSTALLATION

Mounting

Flojet 2100 is a self-priming pump. It may be located several feet from the tank, above or below the liquid level. (It is not a submersible pump.) For vertical pump mounting be sure that the motor is located on top. This will prevent water from entering the motor chamber in event of a leak. Pump head may be rotated in 90° increments to simplify plumbing.

Plumbing

For best performance, flexible 3/8-inch minimum hose is recommended instead of rigid piping at the pump. *Use plastic fittings at the pump port. Brass fittings will break pump housing if over tightened.* Do not install pump such that plumbing causes excessive stress on either port.

It is essential that a 20 mesh strainer or filter be installed in the tank or in the pump inlet line to keep large foreign particles out of the system. The use of check valves in the plumbing system may interfere with the priming ability of the pump. Check valves, if used, must have a cracking (opening) pressure of no more than 2 psi.

Electrical

On 115 Volt AC pumps, the black wire lead is common, the white is neutral and green/yellow is ground. On 230 Volt AC pumps, the brown wire lead is common, the blue is neutral and the green/yellow is ground. Never connect the green (or green/yellow) wire to a live terminal. On 12 and 24 Volt DC pumps, match red (+) and black (-) power leads with red and black leads on motor or switch.

Operation

Allow to prime with discharge line (or spray valve) open to avoid airlock. Built in pressure switch will shut off pump automatically when discharge valve is closed and will restart pump when valve is opened. When pump runs out of liquid, it will continue to operate. Running dry will not damage the pump. Turn off manually.

Spray Tip *** VERY IMPORTANT ***

In spraying applications the pressure generated by the pump is generally dependent upon the size of the spray nozzle. An undersized spray nozzle will cause the pump pressure switch to cycle on and off and create a pulsating flow from the pump. To maintain a smooth flow and constant operating pressure, the smallest size spray nozzles that may be used are as follows:

MODEL	MINIMUM NOZZLE SIZE	
	Equiv. Orifice Diam.	Last 2 Digits *
2100-030	.072"	08
2100-031	.062"	06
2100-032	.078"	10
2100-034	.052"	04
2100-035	.078"	10
2100-130	.078"	10
2100-131	.072"	08
2100-132	.094"	15
2100-134	.062"	06
2100-135	.094"	15

* Ref. Spraying Systems Catalog

TROUBLE SHOOTING

Failure to Prime —

Motor Operates, But No Pump Discharge

- Restricted intake or discharge line. Open all line valves, check for "jammed" check valve poppets and clean clogged lines.
- Air leak in intake line.
- Punctured pump diaphragm.
- Defective pump check valve.
- Crack in pump housing.
- Debris in check valves.

Motor Fails to Turn On

- Pump or equipment not plugged in electrically. Loose wiring connection.
- Pressure switch failure.
- Defective motor or rectifier.
- Frozen cam/bearing.

Pump Fails to Turn Off after Discharge Valves are Closed

- Depletion of available liquid supply.
- Punctured pump diaphragm.
- Discharge line leak.
- Defective pressure switch.
- Insufficient voltage to pump.
- Debris in check valves.

Low Flow and Pressure

- Air leak at pump intake.
- Accumulation of debris inside pump and plumbing.
- Worn pump bearing (excessive noise).
- Punctured pump diaphragm.
- Defective rectifier or motor.
- Insufficient voltage to pump.

Pulsating Flow — Pump Cycling On and Off

- Restricted pump delivery. Check discharge lines, fittings, valves and spray nozzles for clogging or undersizing.

2100 SERIES DEMAND PUMP

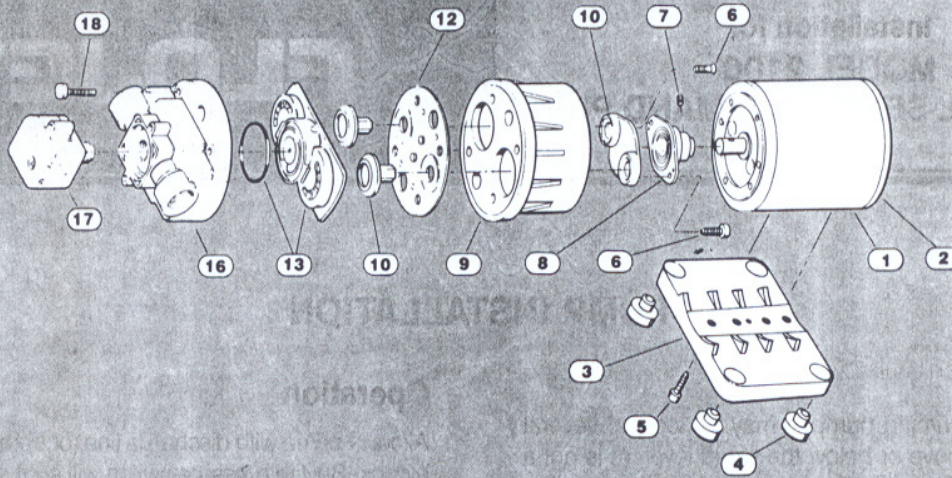

KEY	PART NO.	DESCRIPTION	QTY.	
1	02029-000	Motor 115 Volt AC TENV	1	
	02029-026	Motor 115 Volt AC TEFC	1	
	02039-001	Motor 230 Volt AC TENV	1	
	02039-031	Motor 230 Volt AC TEFC	1	
	02009-004	Motor 12 Volt DC TENV	1	
	02009-015	Motor 12 Volt DC TEFC	1	
	2	20115-111	Brush Endbell/Rect. Assy. (AC) TENV	1
20115-219		Brush Endbell/Rect. Assy. (AC) TEFC no bearing	1	
20115-116		Brush Endbell Assy. (DC) TENV	1	
20115-213		Brush Endbell Assy. (DC) TEFC no bearing	1	
**		20252-500	Internal Rectifier w/Leads	1
3		11028-101	Motor Base Plate Assy. Plastic	1
4	20132-000	Grommets	Set of 4	
5	20131-002	Baseplate Screws	Set of 2	
CAM BEARING / DIAPHRAGM KIT				
Kit	21004-100	#0 Cam, VITON® Diaphragm	1	
Incl.	21004-200	#0 Cam, BUNA Diaphragm	1	
6, 7	21004-400	#0 Cam, SANTO Diaphragm	1	
8	21004-101	#1 Cam, VITON® Diaphragm	1	
10	21004-201	#1 Cam, BUNA Diaphragm	1	
12	21004-401	#1 Cam, SANTO Diaphragm	1	

KEY	PART NO.	DESCRIPTION	QTY.
Kit	21004-102	#2 Cam, VITON® Diaphragm	1
Incl.	21004-202	#2 Cam, BUNA Diaphragm	1
6	21004-402	#2 Cam, SANTO Diaphragm	1
7	21004-104	#4 Cam, VITON® Diaphragm	1
8	21004-204	#4 Cam, BUNA Diaphragm	1
10	21004-404	#4 Cam, SANTO Diaphragm	1
12	21004-105	#5 Cam, VITON® Diaphragm	1
	21004-205	#5 Cam, BUNA Diaphragm	1
	21004-405	#5 Cam, SANTO Diaphragm	1
9	20428-100	Bearing Cover Poly Pro	1
13		Check Valve Assembly (Std)	
	20028-008	SANTOPRENE	1
	20028-009	BUNA	1
	20028-035	VITON®	1
16	20500-507	Pump Housing Poly Pro	1
	20500-508	Pump Housing Nylon	1
17	02095-100	Pressure Switch Ass'y. 60 PSI	1
18	20131-001	Pump Screws	Set of 6
	21050-	Pump Head Ass'y	
6-18		Use Pump Dash Number for Pump Head Dash Number	
		Fan Shroud Kit	1
**	20132-005	Brush Kit	1
**	20097-000	For 115 & 230 Volt AC Motor	Set of 2
	20097-001	For 12 & 24 Volt DC Motor	Set of 2

® A registered trademark of E.I. duPont de Nemours & Co. Inc.

** Not shown in diagram.

TENV - Totally enclosed, non-ventilated

TENC - Totally enclosed, fan cooled.

Service Tips

Refer to exploded view for key number. To disassemble, remove six pump head screws (18), rotate bearing cover (9) so drain notch is aligned with cam/bearing assembly set screw (7), loosen set screw (use 1/8" size Allen Wrench) and slide pump head off shaft. Pistons (10) should always be replaced when new diaphragm is installed, Replace worn parts and reassemble. Be sure raised side of diaphragm faces the motor and radiused corner of pistons face diaphragm. Hex stem of inner piston (10) must be aligned (free to enter) into Hex hole in outer piston set (10). Press pistons together by hand until pistons snap tight. Install flat head screws (6) through outer piston set and tighten screws partially, center pistons in diaphragm then tighten screws securely. Place cam bearing assembly over outer piston set, align locating pins in the holes in cam bearing assembly. Install round head screws and tighten securely. (Torque to 18 inch pounds, coat motor shaft with grease prior to assembly.)

Reassemble bearing and cam bearing assembly to motor and retighten the set screw securely. Set screw MUST be positioned in shaft indentation.

Position of the screw is critical to avoid misalignment and subsequent diaphragm damage.

Reassemble remaining pump head parts, using care to properly seat "O" ring (13) in check valve assembly and tighten pump head screws evenly.

Add the prefix 'FL' to the listed Flojet part numbers to derive the correct Spray Tech part number.

MINI DEMAND PUMPS



LF 12

Duplex Diaphragm Design

- Compact Design Measuring 6.4" (162 mm) in Length
- Fully Automatic Demand Pump
- Self-priming and Can Operate Dry Without Damage
- Built-in Thermal Protector
- Sealed Pressure Switch and Motor
- Flow Rates to 1.0 GPM (3.8 L/min.) and Operating Pressures to 25 PSI

FLOJET

LF 12 SERIES

SPECIAL FEATURES

- Compact automatic demand pump.
- Sealed pressure switch automatically starts and stops pump when discharge valve is opened and closed.
- Self-priming so pump can be located above supply tank.
- Can run dry for extended periods of time without damage.
- Built-in thermal protector.
- Low amp draw for battery powered applications.
- Soft compliant Santoprene® mounting system.

SPECIFICATIONS - LF12

Pump Design	Reciprocating Diaphragm
Flow Rate	1.0 GPM (3.8 L/min.) Nominal @ Open Flow
Duty Cycle	Intermittent
Wetted Parts	Housing Polypropylene Diaphragm Santoprene® Check Valve Viton® or EPDM Check Valve Spring 316 Stainless Steel
Minimum Tip Size	#8 Tip, .072" (1.83 mm) Diameter
Port Type	3/8" (9.5 mm) Hose Barb
Operating Pressure	25 PSI (1.7 bar) Maximum
Pressure Switch Setting	35 PSI (2.4 bar) Off 25 PSI (1.7 bar) On
Self-Priming	Up to 2.5 ft (.76 m) Vertically
Liquid Temperature	110°F (43°C) Maximum
Motor type	Permanent Magnet Motor
Motor Voltage	12 VDC
Current	2.5 Amp Nominal @ 25 PSI (1.7 bar)
Approvals	CE

PERFORMANCE - LF12

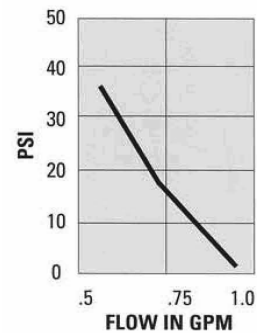

Model No.	Diaphragm	Check Valve	Pressure Switch Setting PSI (bar)	Manual On/Off Switch	Motor Housing	Protection
FL12220-01DI	Santoprene	Viton	35 (2.4)	No	Plastic	Thermal

DIMENSIONS inches (mm)

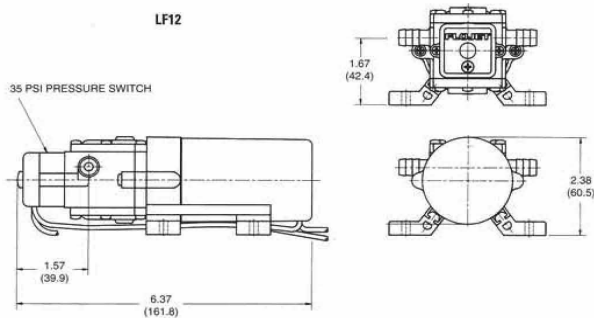

SHUR-FLO

8000 Series Diaphragm Pumps – Automatic Demand 12 VDC

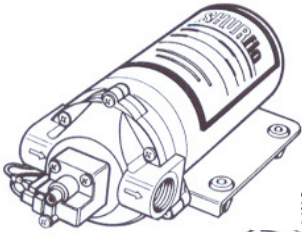

Features

- Self priming up to 8 feet [2.4m]
- Chemical resistant materials
- Designed for heavy duty spraying and fluid transfer applications
- Can run dry without damage

The 8000 Series diaphragm pump is Shurflo's most widely used agriculture pump. With its conical shaped viton valves and automatic demand switch. The 8000 Series pump is the pump of choice for sprayers used on the farm or around the yard. These 12 VDC pumps deliver up to 1.4 gpm [5.3 lpm] providing maximum performance in a wide range of applications.

Model	Description	psi	gpm	Amps
SF8000-236	Lawn and Garden Pump 25 gallon [95 lt] tank or less, 1.0 gpm [3.8 lpm] open flow, Viton valves, Santoprene diaphragm, 60 psi [4.1 bar] Demand Switch, 3/8" NPT-Female ports.	20	.89	1.5
		40	.70	3.2
		60	.62	3.8
SF8030239	150psi High Pressure Pump 1.5 gpm open flow, viton valves, santoprene diaphragm, 150 psi demand switch, 3/8" fpt ports.	80	.94	4.6
		100	.86	6.3
		150	.61	7.5

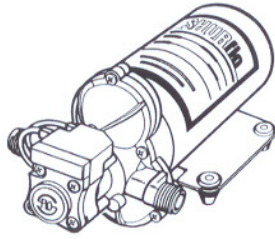

Features

- Self Priming up to 12 feet [3.7 m]
- Can run dry without damage
- Built-in check valve (*may vary on models*) prevents back flow of fluid into the solution tank
- Continuous duty motor (*fin cooled version only*)
- Chemical resistant materials
- Automatic demand

Shurflo 2088 Series diaphragm pumps are considered to be the workhorse of pumps. They are used in a variety of spot spraying, mini-bulk transfer and fertilizer applications that require flows of up to 3.6 gpm [13.6 lpm]. They are available in a variety of chemical resistant materials.

Model	Description	psi	gpm	Amps
2088-343-135	Standard Pump 3.0 gpm [11.3 lpm] open flow, Viton valves, Santoprene diaphragm, 45 psi [3.1 bar] Demand Switch, 1/2" MSPT* ports.	10	2.80	5.3
		30	2.36	6.7
		50	1.42	8.0

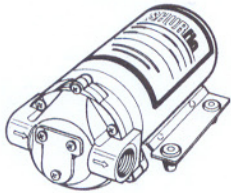

Standard By-Pass

Features

- Self priming up to 8 feet [2.4 m]
- Chemical resistant materials
- Internal bypass
- Can run dry without damage

Additional features of pump with Elect. Pkg.

- Built in on/off switch included
- In-line fuse assembly provided

These Shurflo internal bypass pumps are the answer to applications where an automatic demand switch is not required. Pumps with by-pass will continue to run at high pressure. Ideal for intermittent duty applications. They incorporate a triple chamber with viton elastomers to withstand the toughest of applications. Perfect for spot sprayers, foam markers and transfer applications where smooth consistent flow is needed.

Model	Description	psi	gpm	Amps
8000-543-250	Standard By-Pass Pump 1.4 gpm [5.3 lpm] open flow, Viton valves, Santoprene diaphragm, 45 psi [3.1 bar] internal by-pass, 3/8" NPT-Female ports.	20	1.20	3.9
		40	1.10	5.2
		60	1.00	6.2

Add the prefix **'SF'** to the listed Shurflo part numbers to derive the correct Spray Tech part number.

8000 Series Parts Kit List

Add the prefix 'SF' to the listed Shurflo part numbers to derive the correct Spray Tech part number.

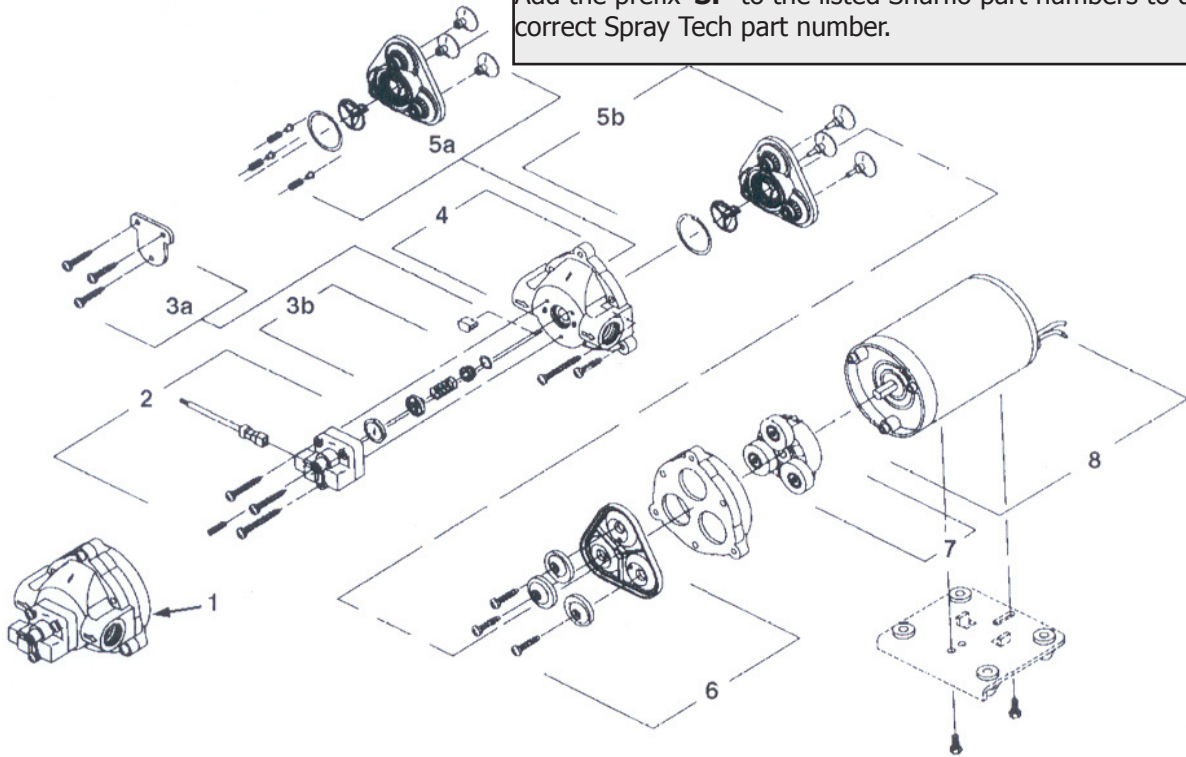

Model Number	1 Complete Pumphead Assembly	2 Switch Assembly	3a/3b Check Valve Assembly	4 Upper Housing	5a/5b By-Pass/Non By-Pass Valve Assembly	6 Diaphragm Assembly	7 Drive/Impeller Assembly	8 Motor
8000-033-236	94-380-05	94-375-05	94-374-10	94-379-00	94-390-05	94-395-06	94-385-04	11-150-00
8000-343-236	94-380-05	94-375-05	94-374-10	94-379-00	94-390-05	94-395-05	94-385-04	11-111-00
8000-533-236	94-380-02	94-375-05	94-374-10	94-379-00	94-390-05	94-395-06	94-385-03	11-150-00
8000-533-250	N/A	N/A	N/A	94-379-00	94-391-09	94-395-06	94-385-03	11-150-00
8000-541-236	N/A	94-375-06	94-374-05	94-379-00	94-390-05	94-395-06	94-385-02	11-148-04
8000-542-136	N/A	94-375-05	94-374-05	94-378-00	94-390-05	94-395-06	94-385-04	11-111-00
8000-542-296	N/A	94-375-05	94-374-05	94-379-00	94-391-07	94-395-06	94-385-04	11-111-00
8000-543-136	N/A	94-375-06	94-374-05	94-378-00	94-390-05	94-395-06	94-385-03	11-111-00
8000-543-236	94-380-02	94-375-06	94-374-05	94-379-00	94-390-05	94-395-06	94-385-03	11-111-00
8000-543-238	N/A	94-375-18	94-374-05	94-379-00	94-390-05	94-395-06	94-385-03	11-111-00
8000-543-250	94-382-09	N/A	N/A	94-379-00	94-391-09	94-395-06	94-385-03	11-111-00
8000-543-290	N/A	N/A	N/A	94-379-00	94-390-05	94-395-06	94-385-03	11-111-00
8000-543-936	94-380-02	94-375-06	94-374-05	94-379-00	94-390-05	94-395-06	94-385-03	11-111-04
8000-643-236	N/A	94-375-04	N/A	94-379-00	94-390-10	94-395-10	94-385-03	11-111-00
8006-543-236	94-380-02	94-375-06	94-374-05	94-379-00	94-390-05	94-395-06	94-385-03	11-111-07
8006-543-250	94-382-09	N/A	N/A	94-379-00	94-391-15	94-395-06	94-385-03	11-111-07
8007-543-236	94-380-02	94-375-06	94-374-05	94-379-00	94-390-05	94-395-06	94-385-03	11-184-00
8007-543-250	N/A	N/A	N/A	94-379-00	94-391-07	94-395-06	94-385-03	11-168-01
8020-503-250	94-382-09	N/A	N/A	94-379-00	94-391-08	94-395-06	N/A	11-194-00
8020-513-236	94-380-02	94-375-06	N/A	94-379-00	94-390-05	94-395-06	N/A	11-194-01
8020-833-238	94-380-28	94-375-15	N/A	94-379-01	94-390-15	94-395-16	N/A	11-195-01
8030-813-239	N/A	94-375-15	N/A	94-379-01	94-390-15	N/A	N/A	11-227-00
8030-863-239	N/A	94-375-15	94-374-10	94-379-01	94-390-15	N/A	N/A	11-223-00

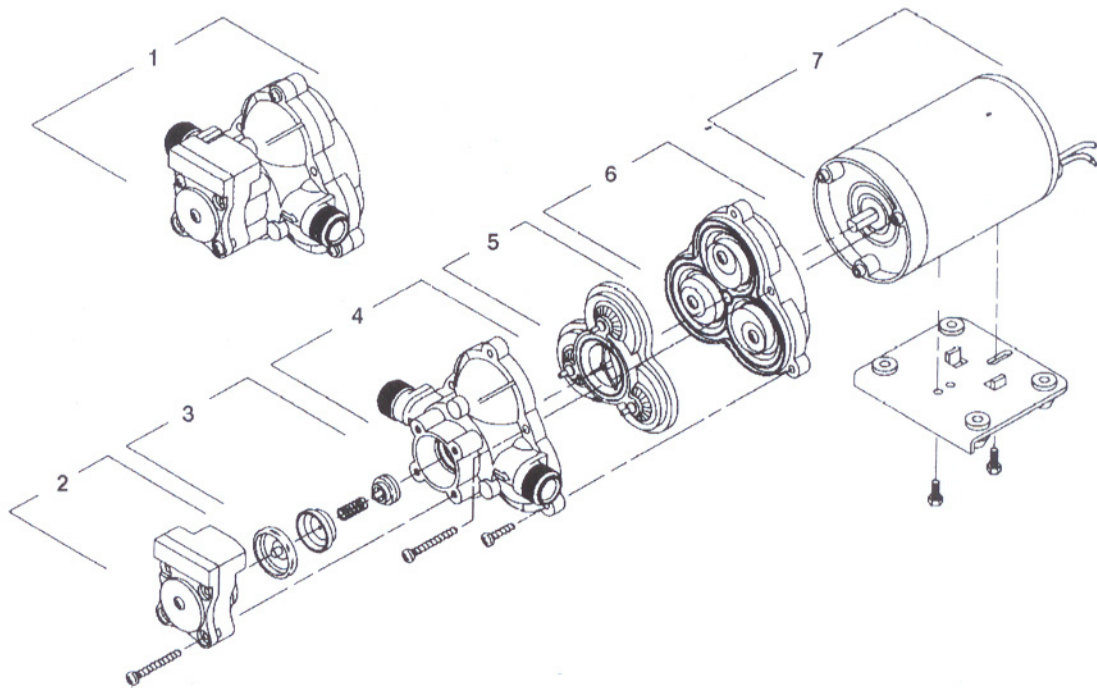

Model Number	1 Complete Pumphead Assembly	2 Switch Assembly	3 Check Valve Assembly	4 Upper Housing	5 By-Pass/Non By-Pass Valve Assembly	6 Drive/Impeller Diaphragm Assembly	7 Motor
2088-313-145	94-236-15	95-231-05	94-237-05	94-232-05	94-232-05	94-009-03	11-185-06
2088-343-135	N/A	94-231-05	94-237-05	94-231-30	94-232-05	94-009-02	11-111-00
2088-343-170	N/A	N/A	N/A	94-231-30	94-232-05	94-009-02	11-174-01
2088-343-500	N/A	N/A	N/A	94-231-30	94-232-05	94-009-02	11-111-00
2088-394-144	94-236-11	94-230-36	N/A	94-231-30	94-232-05	94-238-13	11-195-01
2088-394-154	N/A	94-231-05	94-237-05	94-231-30	94-232-05	94-009-02	11-150-10

Add the prefix 'SF' to the listed Shurflo part numbers to derive the correct Spray Tech part number.

TANKS

Norwesco Elliptical Tanks



(cradle not included)

Description	W x H x L	Specifications & Color	Part Number
200 Gallon	40 x 26 x 66	Δ, Y	NW47086
300 Gallon	48 x 30 x 70	□, Y	NW47349
400 Gallon Φ	57 x 36 x 70	□, Y	NW47389

Norwesco Applicator Tanks

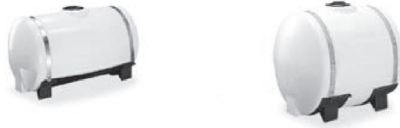

(cradle and straps not included)

Description	D x L	Specifications & Color	Part Number
25 Gallon	23 x 19	Ω, Y	NW47006
55 Gallon	23 x 37	Ω, Y	NW47337
85 Gallon	23 x 55	Ω, Y	NW47394
110 Gallon	30 x 44	Δ, Y	NW47368
150 Gallon	30 x 56	Δ, Y	NW47327
200 Gallon	32 x 65	Δ, Y	NW47068
300 Gallon	38 x 69	Δ, Y	NW47375
400 Gallon ◇	42 x 76	Δ, Y	NW47331
500 Gallon ◇	48 x 74	Δ, Y	NW47330

Norwesco Inductor Tanks



(tank stand of this design neither included nor available)

Description	D x H	Specifications & Color	Part Number
15 Gallon	19 x 23	†, Y	NW41346
35 Gallon	23 x 29	†, Y	NW62438
60 Gallon ◇	31 x 32	∞, Y	NW41340
80 Gallon ◇	32 x 34	∞, Y	NW47373

Norwesco PCO Tanks



Description	W x H x L	Specifications & Color	Part Number
15 Gallon	12 x 15 x 25	♣, Y	NW47024
30 Gallon	19 x 20 x 25	♣, Y	NW47022
50 Gallon	19 x 20 x 38	♣, Y	NW47013
100 Gallon	30 x 26 x 38	♣, Y	NW47020
150 Gallon	36 x 26 x 48	●, Y	NW47350

Norwesco Tractor-Mounted Space-Saver Tanks

Description	W x H x L	Specifications & Color	Part Number
200 Gallon	24 x 47 x 54	Δ, Y	NW47344
250 Gallon	24 x 53 x 60	Δ, Y	NW47340





Specifications

Δ	10" Lid (NW67398), 1 1/4" Double thread fitting (NW60403), 1 1/4" Anti-Vortex fitting (NW63065)
Ω	5" Lid (NW63484), 3/4" Double thread fitting (NW60401)
□	16" Lid (NW60038), 1 1/4" Double thread fitting (NW60403), 1 1/4" Anti-Vortex fitting (NW63065)
♣	5" Lid (NW63484)
●	10" Lid (NW67398)
∞	16" Lid (NW60038), 2" Double thread fitting (NW60405)
†	8" Lid (NW60002), 2" Double thread fitting (NW60405)

Tank Color codes: **Y** - Yellow, **B** - Black, **W** - White

◇ Not a standard stock item - special order item, unless in a pre-season order.

Φ Requires metal tank straps to secure to cradle.

TANKS			
Norwesco Pickup Tanks ◇			
Description	W x L	Specifications & Color	Part Number
210 Gallon	53 x 60	Δ, Y	NW47361
325 Gallon	59 x 62	Δ, Y	NW47354
450 Gallon	59 x 75	Δ, Y	NW47356
Vertical Storage Tanks			
Description	D x H	Specifications & Color	Part Number
Norwesco 65 Gallon ◇	23 x 43	†, Y	NW41347
Norwesco 110 Gallon ◇	29 x 42	Ω, Y	NW47333
Norwesco 300 Gallon ◇	42 x 59	Δ, Y	NW47153
Norwesco 550 Gallon	67 x 44	∞, Y	NW41339
Norwesco 1100 Gallon	84 x 57	∞, Y	NW47713
Norwesco 1550 Gallon	87 x 67	∞, Y	NW45218
Snyder 550 Gallon	64 x 46	B	SN167HD
Snyder 550 Gallon	64 x 46 ½		SN182
Snyder 1650 Gallon	86 x 80		SN1650V1.9
Snyder 2000 Gallon	90 x 87 ½		SN2000V1.9
Snyder 2500 Gallon	90 x 107		SN2500V1.9
Horizontal Leg Tanks		 (hoops not included)	
Description	W x H x L	Specifications & Color	Part Number
Norwesco 500 Gallon	48 x 51 x 75	∞, Y	NW47358
Norwesco 750 Gallon	48 x 51 x 107	∞, Y	NW47211
Norwesco 1000 Gallon	48 x 51 x 139	∞, Y	NW47274
Snyder 1650 Gallon	48 x 50 x 139	B	SN1025B
Snyder 1600 Gallon	68 x 50 x 140		SN1600LEG
Snyder 2600 Gallon	82 x 70 x 155		SN2600BTNK
Specialty Tanks			
Description	W x H x L	Specifications & Color	Part Number
9 Gallon Safety Water	10 x 14 x 20	●, W	NW47036
15 Gallon Lawn & Garden	15 x 11 x 30	⌘, Y	NW47029
25 Gallon Lawn & Garden	20 x 14 x 30	⌘, Y	NW47033
◇ Not a standard stock item - special order item, unless in a pre-season order.			

Specifications	
Δ	10" Lid (NW67398), 2" Double thread fitting (NW60405), siphon tube (NW60335)
Ω	10" Lid (NW67398), ¾" Double thread fitting (NW60401)
⌘	5" Lid (NW63484)
●	Cap and water spigot
∞	16" Lid (NW60038), 2" Double thread fitting w/siphon tube (NW60337)
†	8" Lid (NW60002), 1 ¼" Double thread fitting (NW60403)
Tank Color codes: Y - Yellow, B - Black, W - White	

BULKHEAD FITTINGS & PARTS

Norwesco Standard Bulkhead Fittings with O-rings (Raven Tank Style)

Part Number	Description	Hole Size for Installation
NW67158 NW67161 NW67111 NW67160 NW67159 NW67162	1/2" Single Thread 1/2" Double Thread 3/4" Single Thread 3/4" Double Thread 1" Single Thread 1" Double Thread	1 11/16"
NW67114 NW67155 NW67152 NW67157 NW67154 NW67151 NW67156 NW67153 NW67150	1 1/4" Single Thread 1 1/4" Double Thread 1 1/4" Anti-vortex 1 1/2" Single Thread 1 1/2" Double Thread 1 1/2" Anti-vortex 2" Single Thread 2" Double Thread 2" Anti-vortex	2 13/16"
NW67170 NW67169	3" Single Thread 3" Double Thread	4 1/8"
NW67113 NW67116 NW67165 NW67059 NW67061 NW67091 NW67046 NW67050 NW67166	Replacement nut for 1/2, 3/4, and 1" fittings Replacement nut for 1 1/4, 1 1/2, and 2" fittings Replacement nut for 3" fittings EPDM O-ring for 1/2, 3/4, and 1" fittings EPDM O-ring for 1 1/4, 1 1/2, and 2" fittings EPDM O-ring for 3" fittings Viton O-ring for 1/2, 3/4, and 1" fittings Viton O-ring for 1 1/4, 1 1/2, and 2" fittings Viton O-ring for 3" fittings	-

Norwesco Standard Bulkhead Fittings with Gaskets (Norwesco Tank Style)

Part Number	Description	Hole Size for Installation
NW62834 NW60401	1/2" Heavy duty, Double Thread 3/4" Double Thread	1 7/16"
NW62798	3/4" Heavy duty, Double Thread	1 5/8"
NW60427 NW60403 NW63065	1" Double Thread 1 1/4" Double Thread 1 1/4" Anti-vortex	2 1/4"
NW60124 NW60405 NW63481	1 1/2" Double Thread 2" Double Thread 2" Standard duty, Double Thread	3"
NW62299	3" Double Thread ♦	4 1/2"
NW62171	4" Double Thread ♦	5 3/4"

♦ Not a standard stock item - special order item, unless in a pre-season order.

Poly Repair Kit for Tanks

NW67412 (for minor tank repairs only)

Replacement Fillwells

NW67072 5" diameter, flat only

NW67400 10" diameter, threaded
NW67075 10" diameter, flat only

NW60012 16" diameter, threaded

Nylon Tank Straps

BE3102 Nylon tank strap assembly for 300 gallon **and smaller** tanks (requires two per tank)

Steel Tank Bands

BE400TB Steel Tank Band for 400 Gallon Elliptical Tanks



Tank Agitators

HY3371-19 Hypro agitator
DE25467 Delavan agitator
CYSPARGE Spray Tech sparge kit

Tank Cleaner

NUTRA-2 2# Bottle of NutraSol tank cleaner (12 case qty)

Banjo Heavy-Duty Tank Fittings

 Double-Thread Bulkhead Fittings	Size (outlet x inlet)	EPDM	EPDM Gasket	Viton	Viton Gasket	Hole Size
		1/2"	TETF050	OP150G	TETF050V	OP150GV
	3/4"	TETF075	OP150G	TETF075V	OP150GV	1 5/8"
	1"	TETF100	OP200G	TETF100V	OP200GV	2 1/4"
	1 1/4"	TETF125	OP200G	TETF125V	OP200GV	2 1/4"
	1 1/2"	TETF150	OP300G	TETF150V	OP300GV	3"
	2"	TETF200	OP300G	TETF200V	OP300GV	3"
	2" Full Port	TETF220	TETF220G	TETF220V	TETF220GV	3 1/4"
	3"	TETF300	TETF300G	TETF300V	TETF300GV	4 1/2"
Stainless Steel Double-Thread Bulkhead Fittings	3/4"	TETF075SS	OP150G	-	OP150GV	1 5/8"
	1"	TETF100SS	OP200G	-	OP200GV	2 1/4"
	1 1/4"	TETF125SS	OP200G	-	OP200GV	2 1/4"
	1 1/2"	TETF150SS	OP300G	-	OP300GV	3"
	2"	TETF200SS	OP300G	-	OP300GV	3"
	2" Full Port	TETF220SS	TETF220G	-	TETF220GV	3 1/4"
	3"	TETF300SS	TETF300G	-	TETF300GV	4 3/8"
Anti-Vortex Tank Flanges ◊	1"	-	OP200G	TETF100AV	OP200GV	2 1/4"
	1 1/4"	-	OP200G	TETF125AV	OP200GV	2 1/4"
	1 1/2"	-	OP300G	TETF150AV	OP300GV	3"
	2"	-	OP300G	TETF200AV	OP300GV	3"
 Bolted Tank Flanges	3/4" x 1"	TEBF075	TEBF100GE	TEBF075V	TEBF100GV	-
	1" x 1"	TEBF100	TEBF100GE	TEBF100V	TEBF100GV	-
	1 1/4" x 1"	TEBF125	TEBF100GE	TEBF125V	TEBF100GV	-
	1 1/2" x 2"	TEBF150	TEBF200GE	TEBF150V	TEBF200GV	-
	2" x 2" Std port	TEBF200	TEBF200GE	TEBF200V	TEBF200GV	-
	2" x 2" Full port	TEBF220	OP200G	TEBF220V	OP200GV	-
	3" x 3"	TEBF300	TEBF300GE	TEBF300V	TEBF300GV	-
Manifold Bolted Tank Flanges	1" flange X 1" fpt	TEMBF100	TEBF100GE	TEMBF100V	TEBF100GV	-
	2" std port flange X 2" fpt	TEMBF200	TEBF200GE	TEMBF200V	TEBF200GV	-
	2" full port flange X 2" fpt	TEMBF220	OP200G	TEMBF220V	OP200GV	-
	3" flange X 3" fpt	TEMBF300	TEBF300GE	TEMBF300V	TEBF300GV	-
Bottom-Drain Bolted Tank Flanges	Size (outlet x inlet)	EPDM	EPDM Gasket	Viton	Viton Gasket	Foot Gasket (add V for Viton)
	3/4" x 1"	TEBF075BD	TEBF100GE	TEBF075BDV	TEBF100GV	TEBF100GFE
	1" x 1"	TEBF100BD	TEBF100GE	TEBF100BDV	TEBF100GV	TEBF100GFE
	1 1/4" x 1"	TEBF125BD	TEBF100GE	TEBF125BDV	TEBF100GV	TEBF100GFE
	1 1/2" x 2"	TEBF150BD	TEBF200GE	TEBF150BDV	TEBF200GV	TEBF200GFE
	2" x 2" Std port	TEBF200BD	TEBF200GE	TEBF200BDV	TEBF200GV	TEBF200GFE
	2" x 2" Full port	TEBF220BD	TEBF220GE	TEBF220BDV	TEBF220GV	TEBF220GFE
3" x 3"	TEBF300BD	TEBF300GE	TEBF300BDV	TEBF300GV	TEBF300GFE	
Manifold Bottom-Drain Bolted Tank Flanges ◊	1" flange X 1" fpt	TEMBF100BD	TEBF100GE	TEMBF100BDV	TEBF100GV	TEBF100GFE
	2" std port flange X 1 1/2" fpt	TEMBF150200BD	TEBF200GE	TEMBF150200BDV	TEBF200GV	TEBF200GFE
	2" std port flange X 2" fpt	TEMBF200BD	TEBF200GE	TEMBF200BDV	TEBF200GV	TEBF200GFE
	2" full port flange X 2" fpt	TEMBF220BD	OP200G	TEMBF220BDV	OP200GV	TEBF200GFE
	3" flange X 3" fpt	TEMBF300BD	TEBF300GE	TEMBF300BDV	TEBF300GV	TEBF300GFE

◊ Not a standard stock item - special order item, unless in a pre-season order.

 Banjo Polypropylene Siphon Tubes	Part No.	Size
		TEST200
	TEST300	3"

TeeJet® Tank Rinsing Nozzles

27500

- The 27500 tank rinsing nozzle has a fluid-driven rotational spray head with orifices positioned to provide effective rinsing of sprayer tanks.



27500E

- 27500E-R spray head can easily be removed for inspection and maintenance.
- Provides 360° coverage of inside surface of tank.



27500R

NOZZLE NUMBER	CAPACITY - GPM					TYPE OF COVERAGE	SPRAY ANGLE
	10 PSI	20 PSI	30 PSI	40 PSI	50 PSI		
Call Spray Tech for price, availability, and part number.	4	5.7	6.9	8	8.9		360°
	9	12.7	15.6	18	20		

(B)=BSPT

- Made of corrosion-resistant Teflon® material.
- Mounting connection— $\frac{3}{4}$ " NPT

Typical Application

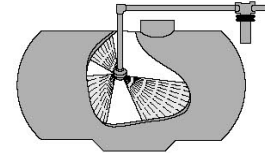

41892

- The rotary tank rinsing nozzle is used for rinsing the insides of chemical containers and spray tanks up to 6.5 ft. (2.0 m) in diameter.



- Available with $\frac{1}{2}$ " NPT
- Significant lower rotating speed at approximately 15% of typical speed,

NOZZLE NUMBER	CAPACITY - GPM				
	20 PSI	30 PSI	40 PSI	50 PSI	60 PSI
Call Spray Tech for price, availability, and part number.	4.0	4.9	5.7	6.4	7.0

- results in faster and more thorough cleaning of tank surface.
- Self-cleaning sliding bearing.
- Body and inserts are made of POM (Acetal).

- Nozzle fits in $1\frac{1}{2}$ " (37 mm) opening.
- Recommended operating pressure 30–60 PSI (2–4 bar) with a maximum pressure 115 PSI (8 bar).

TeeJet® Container Rinsing Nozzles

23240

- The 23240 container rinsing nozzle is used to rinse residue from containers before disposal.
- Can be used for containers with $1\frac{1}{2}$ " (26 mm) diameter openings or larger.
- Three flat spray orifices provide self-rotational forces needed to create spherical coverage.
- Available in $\frac{1}{2}$ " NPT



NOZZLE NUMBER	INLET PIPE CONNECTION	CAPACITY - GPM				
		20 PSI	30 PSI	40 PSI	50 PSI	60 PSI
Call Spray Tech for price, availability, and part number.	$\frac{1}{2}$ " (F)	4.0	4.9	5.7	6.4	7.0
		4.9	6.1	7.0	7.8	8.6

- Made of 316 stainless steel with hardened stainless steel bearings and races for maximum wear life. Also includes an internal sleeve made of Nylon.

Typical Application

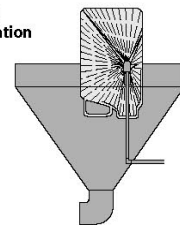

VSM-*

- Used for inside rinsing of chemical containers.
- 40 orifices combine to produce a 240° spray angle.
- All Nylon construction.
- Available with $\frac{1}{2}$ " or $\frac{3}{4}$ " NPT
- Recommended operating pressure 30–60 PSI (2–4 bar).



NOZZLE NUMBER	INLET PIPE CONNECTION	ORIFICE DIAMETER	CAPACITY - GPM						SPRAY ANGLE
			20 PSI	30 PSI	40 PSI	60 PSI	80 PSI	100 PSI	
Call Spray Tech for price, availability, and part number.	$\frac{1}{2}$ " (F)	.031"	3.9	4.8	5.5	6.7	7.8	8.7	240°
		.039"	6.1	7.5	8.6	10.6	12.2	13.7	
	$\frac{1}{2}$ " or $\frac{3}{4}$ " (F)	.059"	12.5	15.3	17.7	22	25	28	
		.077"	19.4	24	27	34	39	43	
		.091"	26	32	37	46	53	59	

TANK RACKS



Styles:

Front Mount

Trim-View Side Mount

Teardrop Side Mount ◊



Racks often change in design and we constantly have new additions with new tractor models. Call Spray Tech for the appropriate part number for a particular rack. **Please provide the make, model, and year of the tractor in question, along with the desired tank capacity.**

Item	Description	Part Number
Weight Brackets	JD Weight Bkt JD 8020 Weight Bkt MX240 Weight Bkt	BEWTBKTJD BEWTBKTJD2 BEWTBKTMX
One-piece saddles for OVAL tanks Additional saddles are available for round, trim-view, and tear-drop tanks. Call Spray Tech for price and availability.	200 gallon saddle 300 gallon saddle 400 gallon saddle	BE402-N BE403-N BE404-N

◊ Not a standard stock item - special order item.

Spray Tech MIX-N-FILL Tank Stands

(Tank not included)

Size	 Bolt-on style for Water Wagons (INCLUDES backing plate)	 Stand-alone style
15 Gallon	CYFLSBO15	CYFILSTND
35 Gallon	CYFLSBO30	CYFILST30
65 & 80 Gallon	N/A	BEM8

Spray Tech MIX-N-FILL Tank Assemblies

(Includes tank, stand, valve, and connections used for chemical induction to sprayer)		Part Number by Connection Style		
		Hose Barb Connections	Quick Coupler Connections	Manifold Flange Connections
Description	Connection Size			
15 Gallon Mix-n-Fill Assy	1 1/2" 2"	CYFILB150 CYFILB200	CYFILA150 CYFILA200	CYFILM150 CYFILM200
35 Gallon Mix-n-Fill Assy	1 1/2" 2"	CYFILB150L CYFILB200L	CYFILA150L CYFILA200L	CYFILM150L CYFILM200L

SPRAYERS AND SPRAYER KITS

Call Spray Tech for the latest information and prices on spot sprayers, pull-behind rigs, 3-point hitch sprayers, spray booms, and lay-by rigs.

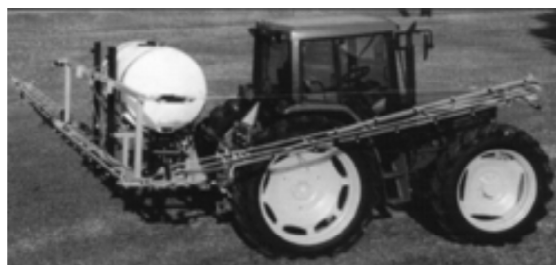
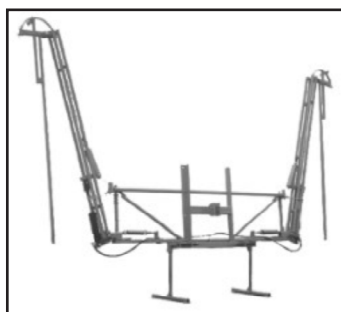

SPRAYER KITS

Sprayer kits for planters, discs, and cultivators aren't as common now as in the past, but with the increasing weed resistance to glyphosate, Spray Tech still offers kits for each. Call Spray Tech with your needs.

ROPE-WICK APPLICATORS AND ACCESSORIES

Rope-A-Dope Ropewick Applicator

Economical weed control using gravity-flow to saturate ropes with chemical, which are then wiped across weeds. Allows use of non-selective herbicides to control Johnsongrass, volunteer corn, shattercane, milkweed and a host of other weeds and grasses without damaging the crop. Eliminates wind drift, splatter, and minimizes chemical usage.

Parallel linkage of tractor mounted lift frame holds ropes at a constant angle as applicator is raised and lowered. Mounts on front of tractor for good visibility and precise application. Applicator moves through a 3 1/2 ft. range, from 1 1/2 to 5 ft. above ground.

Universal mounting brackets fit most tractors (using four grade 8 double heat treated bolts). Special mounting brackets are furnished for John Deere 4010/4020, high clearance tractors, and front wheel assist tractors.

Leak-free, threaded adapters are tightly secured into tapped PVC tube and are completely repairable.

Replacable wick rope has a diamond braid, polyester jacket over an acrylic core for efficient wicking action.

Call Spray Tech for price, availability, and part numbers for the various configurations of the Rope-a-Dope applicator.

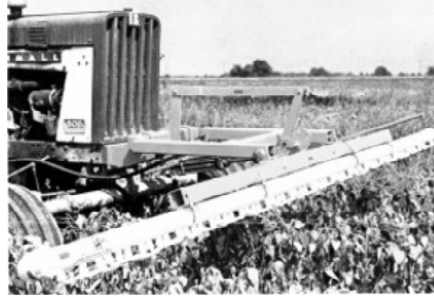

Features:

- Sizes from 40 inches to 30 feet, folding or non-folding models.
- Available with tractor mounted lift frame (complete system) or as pipe/rope only for mounting to front loaders or existing toolbars.
- Large 3" diameter opening makes filling quick and easy.
- Simply pour chemical into tube and wipe saturated ropes across weeds.
- Internal baffles prevent end to end surging.
- Low initial equipment investment and low chemical cost per acre.

ROPE WICK COMPONENTS	
Part Number	Description
BO370102	Complete rope assembly (1 rope)
BOR160	Complete rope assembly (30 ropes)
BOR240	Complete rope assembly (46 ropes)
BOH3850-1	Tube Saddle w/ clamps
BOWT120L BOWR120R	120" Wick Tube, Left or Right
BOWT160L BOWR160R	160" Wick Tube, Left or Right
BOWT180L BOWR180R	180" Wick Tube, Left or Right
BOWT240	240" Wick Tube
BOWT90	90" Wick Tube



Weed Wand Hand-Held rope wick applicator

Safely use non-selective herbicides to kill bermudagrass in flowerbeds without harming the flowers, wipe out weeds without damaging your lawn, trim along sidewalks, driveways, mailboxes, and fences. Even spot control weeds in fields or pastures. Ideal for use with Roundup. Because there is no chance for wind drift or splatter, chemical stays where you put it.

Part Number: **CYWICK**

NEW PRODUCTS / MISCELLANEOUS

**In the
Field**

**In the
Dark**



**Anywhere you
Need to See**



**You Can Clearly See the Difference.
www.agcam.com**

When you need to see, keep it in view with the AgCam® by Dakota Micro Inc., the most comprehensive, user friendly and versatile rear view and monitoring system available!

AGCAM by DAKOTA MICRO

Part No.	Description	Potential Uses
DMAC-B	Monitor Mounting Bracket	<ul style="list-style-type: none"> • Auger Wagons • Combines • Cotton Pickers • Residential or Business Security • Campers
DMAC-C1	Camera w/cables	
DMAC-EC10	10' Video Cable	
DMAC-EC20	20' Video Cable	
DMAC-Q	Quad Processor	
DMAC-RC	Camera w/o cables	
DMAC9MC1	9" Monitor and Camera	
DMACC1-12	Camera-Cables-12mm Lens	
DMACRHPAIR	Ranch Hand Pair (wireless)	
DMACRHWPPR	Waterproof Ranch Hand Pair	



Manifold Inductor System

FEATURES

- Installed after pump; suction completely empties inductor tank.
- Keeps Tank Free of Chemicals.
- 2" & 3" Full Port Flow.
- Easy Assembly/ Installation With Manifold Connections.

Draws Wettable Powders From Inductor Tank for thorough Chemical Mixing.



MANIFOLD VENTURI SYSTEM		
PART NO.	DESCRIPTION	QTY.
MIS220AA	Manifold Inductor System, Male Adapter x Male Adapter 2" Full Port Assembled	1
MIS220AAK	Manifold Inductor System, Male Adapter x Male Adapter 2" Full Port Kit Assembly Required	1

Note: Tank not included.



Top View

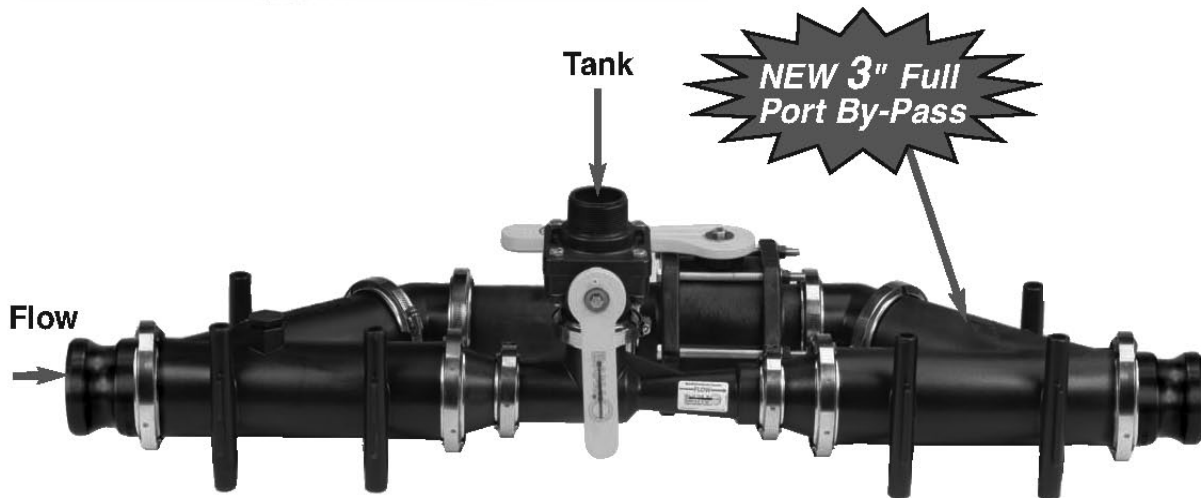

MANIFOLD VENTURI SYSTEM		
PART NO.	DESCRIPTION	QTY.
MIS300AA	Manifold Inductor System, Male Adapter x Male Adapter 3" Full Port Assembled	

Note: Tank not included.

The Spray Tech part number can be derived by adding the prefix 'TE' to the listed Banjo part numbers.

Polypropylene Inductors

FEATURES

- Threaded or Manifold ends.
- Glass filled polypropylene.
- 1 1/2" & 2" sizes available.

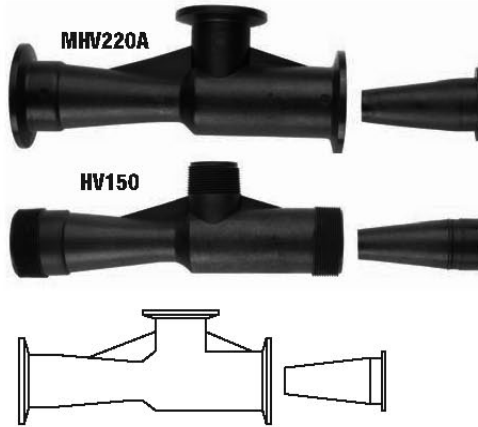

Each venturi comes in two pieces

NOTE: The venturi is designed for use with a volume pump. Typical volumes and pressures used to operate the venturi would be in the 80 to 240 US GPM range at pressures from 26 to 52 P.S.I.

PART NO.	DESCRIPTION	OPENING SIZE	PRESSURE @PUMP	VOLUME DRAW*
HV150	1 1/2" MPT Polypropylene Venturi	5/16"	50 PSI	37 USGPM
HV200	2" MPT Polypropylene Venturi	7/16"	50 PSI	49 USGPM
MHV200	2" Manifold Polypro Venturi 1 1/2" Port	5/16"	50 PSI	37 USGPM
MHV220A	2" FP Manifold Polypropylene Venturi	7/16"	50 PSI	49 USGPM

*Note: Tests done with water at ambient temperature. Pump used for test was a 2" Banjo (5 vane impeller) driven by a 5.5 hp Honda gas motor. Performance may vary depending on pump used & product being pumped.

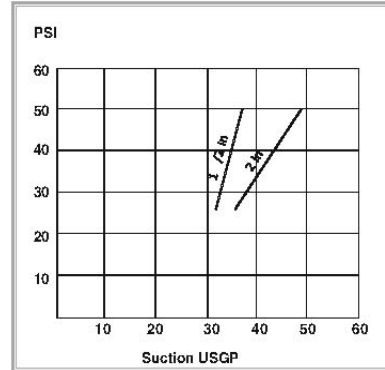

The Spray Tech part number can be derived by adding the prefix 'TE' to the listed Banjo part numbers.

NURSE WAGONS



NEW!

Call Spray Tech for price and availability of various nurse wagon configurations.



BACKPACK & HANDHELD SPRAYERS

BACKPACK SPRAYER

NEW

PART NUMBER

Part#	Description
BPS-400	16 L (4.22 Gal) Capacity, 15-90 PSI

Features

- Lever action piston pump with quick fitting harness.

REPLACEMENT PARTS

Part#	Description
90.700.115	Gun and Wand Assembly
90.700.215	Piston Seal
26.850.004	85 x 4mm Bottom O-Ring
90.700.116	Nozzle Holder Cap
90.700.117	Nozzle Tip, Fan Style
90.700.118	Nozzle Tip, Cone Style
90.700.119	Tank Lid Cap, Blue
90.700.120	Tank Lid Seal
90.700.121	Accessory package for sprayers, includes nozzles and tips
90.700.122	Trigger
90.700.123	Replacement shoulder straps
90.700.124	Replacement pump lever
90.700.125	Piston & Rocker Arm Assy



HANDHELD SPRAYERS

NEW

PART NUMBER

Part#	Description
90700012	1.2 L (40 oz) Capacity
90700065	6.5 L (1.7 Gal) Capacity, 55 PSI Max
90700008	8.0 L (2.1 Gal) Capacity, 55 PSI Max



To derive the Spray Tech part number, add the prefix 'VI' to the above listed part numbers.

HOSE REELS



100 FOOT HOSE REELS

PART NUMBERS

Size	Part#
100 ft. capacity hose reel	VIHR100

FEATURES

• 100 ft. capacity $\frac{3}{8}$ " ID spray hose
• Powder coated steel frame
• Swivel included
• 3000 PSI Max.
• 160° F Max temperature



200 & 400 FOOT HOSE REELS

PART NUMBERS

Size	Part#
200 ft. capacity hose reel	VIHRG200
400 ft. capacity hose reel	VIHRG400
400 ft. capacity hose reel, with garden hose fittings	VIHRG400GH

FEATURES

• 200/400 ft. capacity $\frac{1}{2}$ " ID spray hose
• Powder coated steel frame
• 8 GPM swivel included
• 3000 PSI Max.
• Easy assembly

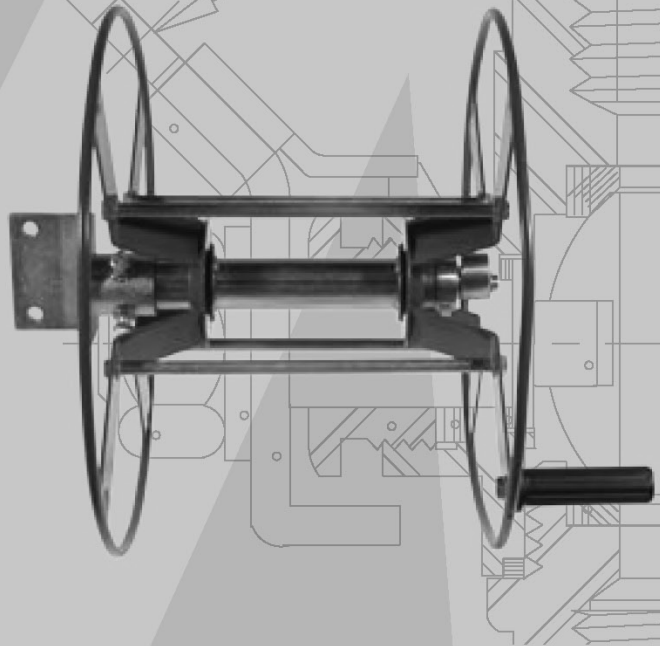

HITCH PINS



NEW

HITCH PINS

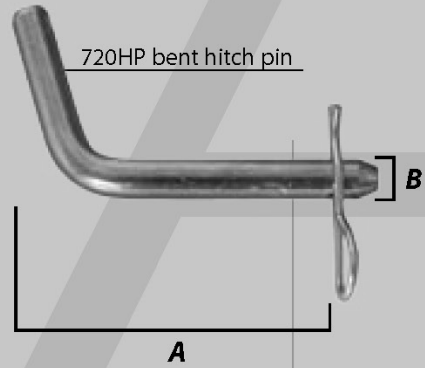
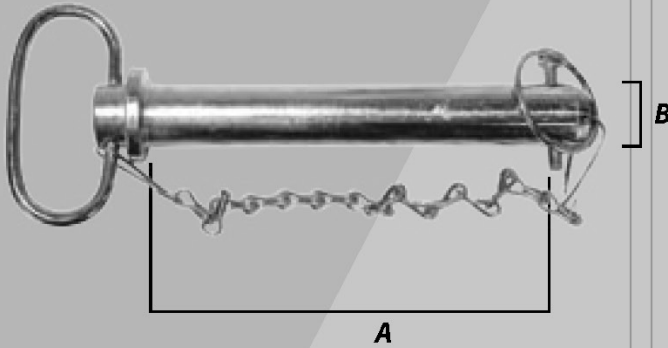

PART NUMBER

Part#	Case#	JD#	Farmex#	NH#	Speeco#	Tisco#	A	B
700HP	B500176	TY4012	14893	251540	P71032CL	PS7506	6¼"	¾"
701HP	B500177	TY4013	17881	251541	P71042CL	PS8756	6¼"	7⁄8"
702HP	N/A	TY4009	15201	251537	P71021CL	PS6254	4¼"	5⁄8"
703HP	B500175	TY4010	15211	251539	P71031CL	PS7504	4¼"	¾"
704HP	B500174	TY15737	14881	251538	P71022CL	PS6256	6¼"	5⁄8"
705HP	B500172	TY15736	22131	251536	P71011CL	PS5004	3½"	½"
706HP	B500178	N/A	17891	251542F	P71052CL	PS1006	6¼"	1"
707HP	B500179	N/A	17901	251543F	P71062CL	PS1126	6¼"	1⅛"
708HP	B500180	N/A	18001	251544	P71072CL	PS1256	6¼"	1¼"
709HP	N/A	N/A	N/A	N/A	N/A	N/A	4¼"	7⁄8"
713HP*	N/A	N/A	01789	N/A	P71052C	PS1006	6¼"	1"
715HP	N/A	N/A	N/A	N/A	P71010C	N/A	4¼"	¾"
720HP	N/A	N/A	01410	N/A	P71111	N/A	3"	½"

*713HP does not include pin

Usable Length
Pin Diameter

NEW

SNAP LOCK-SPRING HITCH PINS

PART NUMBER

Part#	A	B
710HP	4 ½"	½"
711HP	4 ½"	¾"

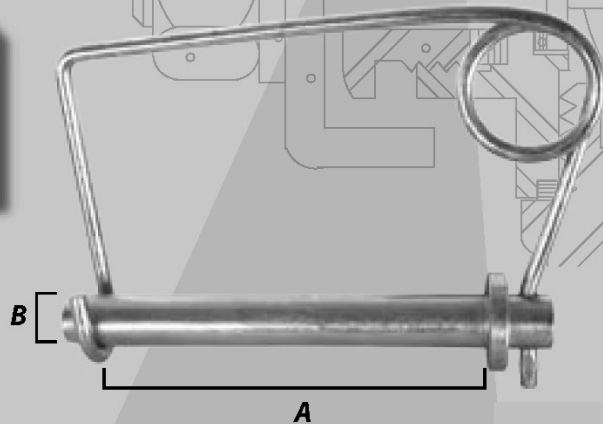

To derive the Spray Tech part number, add the prefix 'VI' to the above listed part numbers.



HITCH PINS

FORGED HITCH PINS

NEW

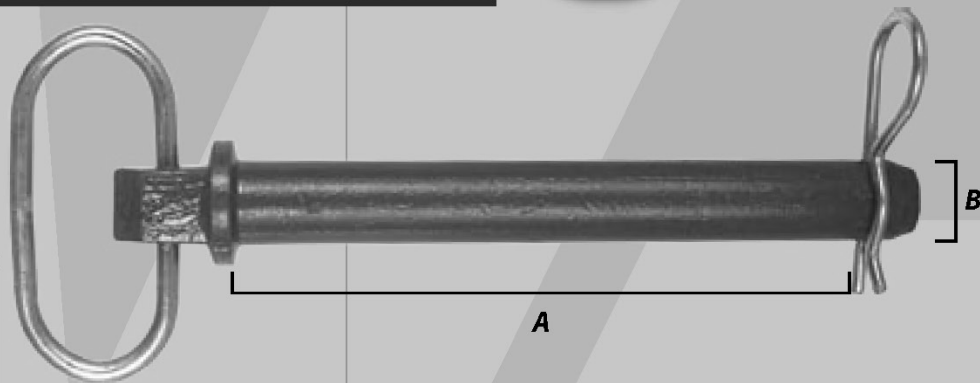

PART NUMBERS

Part#	A (Length)	B (Pin Dia.)	Part#	A (Length)	B (Pin Dia.)
700FHP	6¼"	¾"	705FHP	3½"	½"
701FHP	6½"	7⁄8"	706FHP	6¾"	1"
702FHP	3⅝"	⅝"	707FHP	7"	1⅛"
703FHP	4"	¾"	708FHP	7"	1¼"

RUBBER HANDLED HITCH PINS

NEW



PART NUMBERS

Part# Red	Part# Blue	Case#	Farmex#	NH#	Speeco#	Tisco#	A	B
705HPR	705HPBLU	B504050	1500	HD9613574	P700511	7811	3⅝"	½"
702HPR	702HPBLU	B504051	1501	HD9613575	P700521	7821	4"	⅝"
703HPR	703HPBLU	B504053	1503	HD9613576	P700531	7831	4"	¾"
700HPR	700HPBLU	B504054	1504	HD9613580	P700532	7832	6½"	¾"
701HPR	701HPBLU	B504055	1506	HD9613581	P700542	7842	6½"	7⁄8"
706HPR	706HPBLU	B504056	1508	HD9613582	P700552	7852	7½"	1"
707HPR	707HPBLU	8504057	1510	HD9613583	P700562	7862	8½"	1⅛"
708HPR	708HPBLU	N/A	N/A	N/A	N/A	N/A	8½"	1¼"

All include rubber coated handle. All rubber handled hitch pins are Grade 8 hardness.

To derive the Spray Tech part number, add the prefix **'VI'** to the above listed part numbers.



HAIR PINS & LIFT ARM CHECK CHAIN CLEVIS

HAIR PINS

NEW

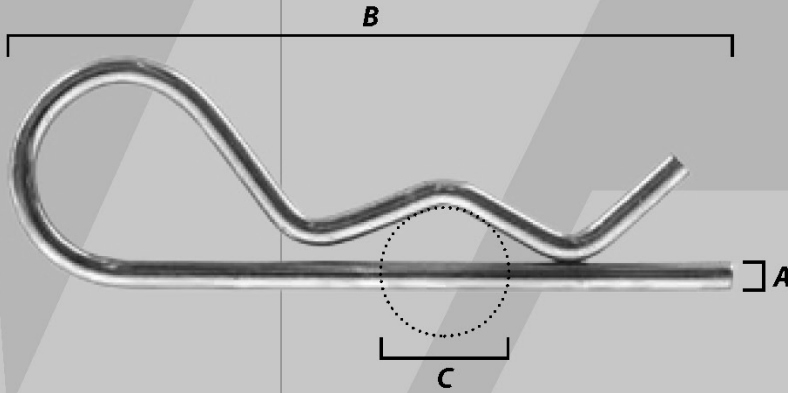

PART NUMBERS

Part#	Case#	Farmex#	Tisco#	Wire Diameter	Overall Length	Diameter
				A	B	C
P-7922	N/A	N/A	N/A	2 (1/16")	42 (1 3/4")	6-11 (3/16" - 7/16")
P-7923	00009	00009	HP6	2.5 (3/32")	43 (1 3/4")	8-12 (7/16" - 9/16")
P-7924	B504905	00010	N/A	3 (1/8")	64 (2 1/2")	10-18 (9/16" - 3/4")
P-7925	B504906	00012	N/A	4 (3/32")	76 (3")	12-22 (3/4" - 7/8")
P-7927	B504907	00013	HP3	5 (1/16")	105 (4")	10-18 (7/8" - 1")
P-7928	N/A	N/A	N/A	6 (1/32")	123 (4 3/4")	16-27 (7/8" - 1 1/8")

To derive the Spray Tech part number, add the prefix 'VI' to the above listed part numbers.

LOCKEASE™

SAFETY HITCH PIN



Simple & Safe!

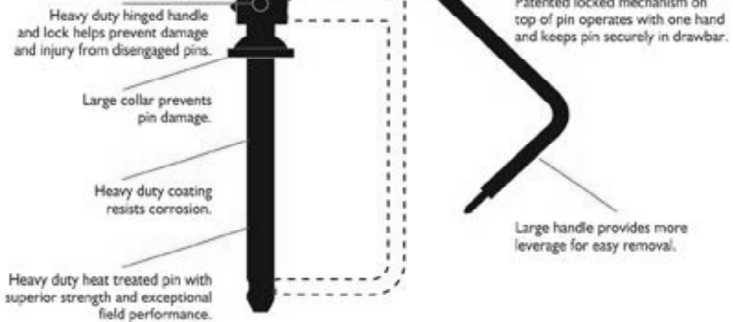

LOCKEASE HITCH PINS

Part No.	Size	Std. Pkg
HH80150	3/4" x 4 1/2"	4
HH80160	3/4" x 6"	4
HH80165	7/8" x 4 1/2"	4
HH80170	7/8" x 6"	4
HH80180	1" x 6"	4
HH80190	1 1/8" x 7"	4
HH80200	1 1/4" x 7"	4
HH80210	1 1/2" x 8"	2

LYNCH & LOCK PINS



NEW

LYNCH PINS

1



2

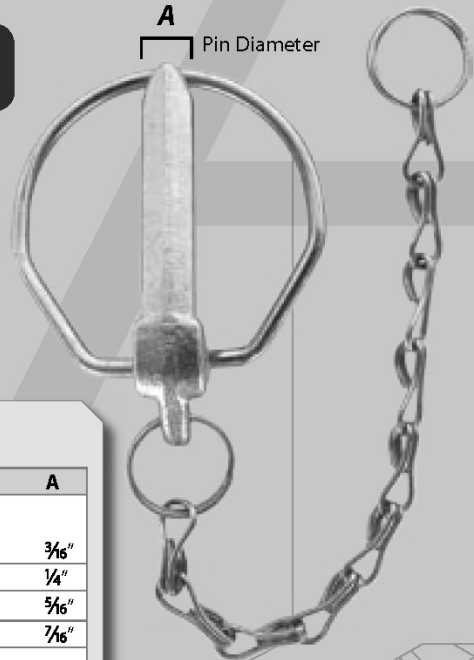

PART NUMBERS

Part#	Case#	Farmex#	Speeco#	Tisco#	Type	A
1						
804LP	<i>Replaces 03548</i>		N/A	N/A	Standard Pin	3/16"
800LP	B500169	2704	P794	DKP 1/4	Standard Pin	1/4"
802LP	B504901	2709	P7915	N/A	Standard Pin	5/16"
801LP	B500170	2703	P791	TKLP91	Standard Pin	7/16"
<i>Available in packages of 100</i>						
803LP	B500171	3027	P7913	DKP-SD-1	Black Ring H.D.	7/16"
805LP	N/A	N/A	N/A	N/A	Standard Pin	3/8"
2						
806LP	N/A	N/A	N/A	DKPWCH	Standard Pin with Chain	7/16"

NEW

LOCK PINS FOR PTO ADAPTERS

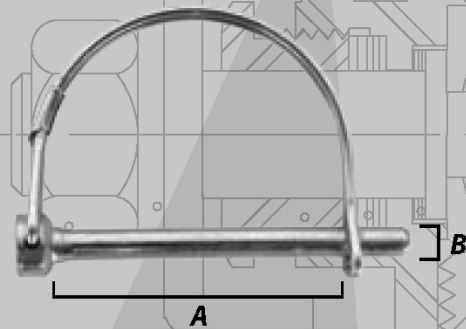
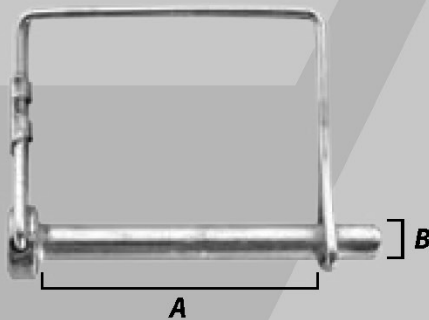

PART NUMBERS

Part#	Farmex#	Speeco#	A	B
904PA	00276	P7939	2 1/4"	5/16" (trailer)
905PA	00265	N/A	2 1/4"	3/8"

PART NUMBERS

Part#	Farmex#	Speeco#	A	B
908PA	N/A	N/A	1 3/4"	1/4"
903PA	00264	N/A	2 1/4"	1/4"
906PA	00275	N/A	2 1/4"	3/8"
900PA	00266	P7940	2 1/4"	5/16"

To derive the Spray Tech part number, add the prefix **'VI'** to the above listed part numbers.

FIRE HOSE NOZZLES

	Part No	Description
	MVPFN150	Adjustable Fire Nozzle (pictured), 1 1/2"
	MVB075	Straight Brass Fire Nozzle, 3/4"
	MVB100	Straight Brass Fire Nozzle, 1"
	MVB125	Straight Brass Fire Nozzle, 1 1/4"
	MVB150	Straight Brass Fire Nozzle, 1 1/2"
	MVB200	Straight Brass Fire Nozzle, 2"

LOVE-JOY COUPLERS

Part No.	Description	
LJ1X406	406 SPIDER L-100	
LJ1X407	407 SPIDER-L-90-95	
LJ1X408	L070 SPIDER	
LJ2X814	L075 SPIDER	
LJ4X178	L070 X 1/2 FLEX	
LJ4X180	L070 X 3/4 FLEX C	
LJ4X185	L90 1/2 SD COUP	
LJ4X186	L90 5/8 SD COUP	
LJ4X187	L90 3/4 SD COUP	
LJ4X188	L90 7/8 SD COUP	
LJ4X191	L95 3/4 MD COUP	
LJ4X192	L95 7/8 MD COUP	
LJ4X193	L95 1 MD COUP	
LJ4X194	L100 1 1/8 COUP	
LJ4X195	L100 1 1/4 HD COUP	
LJ4X196	L100 1 3/8 COUP	
LJ5X075	3/4" #5 COUPLING	
LJ5X118	1 1/8 # 5 COUPLING	
LJ5X402	L075X 7/16 COUP	
LJ6JE	SLEEVE	
LJ6X072	5/8" L-95 MD CUP	
LJ6X073	1 1/8 L-95 COUPLING	
LJ6X074	3/4" L-100 HD CUP	
LJ6X075	7/8" L-100 HD CUP	
LJ6X076	1" L-100 HD COUP	
LJ6X1516	15/16 L95 SD COUP	
LJ75X1/2	L075X1/2 COUP	
LJ75X7/16	L75X7/16 COUP	

CALIBRATION / TECHNICAL INFORMATION

Technical Information

Useful Formulas

$$\begin{aligned} \text{GPM (Per Nozzle)} &= \frac{\text{GPA} \times \text{MPH} \times \text{W}}{5,940} \\ \text{GPM (Per Nozzle)} &= \frac{\text{GAL}/1000\text{FT}^2 \times \text{MPH} \times \text{W}}{136} \\ \text{GPA} &= \frac{5,940 \times \text{GPM (Per Nozzle)}}{\text{MPH} \times \text{W}} \\ \text{GAL}/1000\text{FT}^2 &= \frac{136 \times \text{GPM (Per Nozzle)}}{\text{MPH} \times \text{W}} \end{aligned}$$

GPM – Gallons Per Minute

GPA – Gallons Per Acre

GAL/1000FT² – Gallons Per 1000 Square Feet

MPH – Miles Per Hour

W – Nozzle spacing (in inches) for broadcast spraying
 – Spray width (in inches) for single nozzle, band spraying or boomless spraying
 – Row spacing (in inches) divided by the number of nozzles per row for directed spraying

Nozzle Spacing

If the nozzle spacing on your boom is different than those tabulated, multiply the tabulated GPA coverages by one of the following factors.

20°	
Other Spacing (Inches)	Conversion Factor
8	2.5
10	2
12	1.67
14	1.43
16	1.25
18	1.11
22	.91
24	.83
30	.66

Useful Formulas for Roadway Applications

$$\text{GPLM} = \frac{60 \times \text{GPM}}{\text{MPH}} \quad \text{GPM} = \frac{\text{GPLM} \times \text{MPH}}{60}$$

GPLM = Gallons Per Lane Mile

Note: GPLM is not a normal volume per unit area measurement. It is a volume per distance measurement. Increases or decreases in lane width (swath width) are not accommodated by these formulas.

Measuring Travel Speed

Measure a test course in the area to be sprayed or in an area with similar surface conditions. Minimum lengths of 100 and 200 feet are recommended for measuring speeds up to 5 and 10 MPH, respectively. Determine the time required to travel the test course. To help ensure accuracy, conduct the speed check with a partially loaded (about half full) sprayer and select the engine throttle setting and gear that will be used when spraying. Repeat the above process and average the times that were measured. Use the following equation or the table at right to determine ground speed.

$$\text{Speed (MPH)} = \frac{\text{Distance (FT)} \times 60}{\text{Time (seconds)} \times 88}$$

Speeds

Speed in MPH	Time Required in SECONDS to Travel a Distance of:		
	100 Feet	200 Feet	300 Feet
1.0	68	136	205
1.5	45	91	136
2.0	34	68	102
2.5	27	55	82
3.0	23	45	68
3.5	19	39	58
4.0	17	34	51
4.5	15	30	45
5.0	14	27	41
5.5	—	25	37
6.0	—	23	34
6.5	—	21	31
7.0	—	19	29
7.5	—	18	27
8.0	—	17	26
8.5	—	16	24
9.0	—	15	23

Miscellaneous Conversion Factors

One Acre = 43,560 Square Feet
 = 43.56 1000FT² Blocks
 = 0.405 Hectare

One Hectare = 2.471 Acres

One Gallon Per Acre
 = 2.9 Fluid Ounces per 1000FT²
 = 9.35 Liters Per Hectare

One Gallon Per 1000FT² = 43.56 GPA

One Mile = 5,280 Feet
 = 1,610 Meters
 = 1.61 Kilometers

One Gallon = 128 Fluid Ounces
 = 8 Pints
 = 4 Quarts
 = 3.79 Liters
 = 0.83 Imperial Gallon

One Pound Per Square Inch
 = 0.069 bar
 = 6.896 Kilopascals

One Mile Per Hour
 = 1.609 Kilometers Per Hour

Suggested Minimum Spray Heights

The nozzle height suggestions in the table below are based on the minimum overlap required to obtain uniform distribution. However, in many cases, typical height adjustments are based on a 1 to 1 nozzle spacing to height ratio. For example, 110° flat spray tips spaced 20 inches apart are commonly set 20 inches above the target.

	(Inches)			
	20°	30°	40°	
TeeJet® Standard, TJ	65°	22–24"	33–35"	NR*
TeeJet, XR, TX, DG, TJ	80°	17–19"	26–28"	NR*
TeeJet, XR, DG, TT, TT, TJ, DGTJ, AI, AIXR	110°	16–18"	20–22"	NR*
FullJet®	120°	10–18"***	14–18"***	14–18"***
FloodJet® TK, TF	120°	14–16"****	15–17"****	18–20"****

* Not recommended.

** Nozzle height based on 30° to 45° angle of orientation (see page 30 of catalog).

*** Wide angle spray tip height is influenced by nozzle orientation. The critical factor is to achieve a double spray pattern overlap.

Information in the Calibration / Technical Information section is predominantly taken from the Technical Information section of Teejet Catalog 50. Therefore, some of the information may be specific to Teejet products. Call Spray Tech if you need technical information specific to other manufacturers.

CALIBRATION / TECHNICAL INFORMATION

Technical Information

Spraying Liquids with a Density Other Than Water

Since all the tabulations in this catalog are based on spraying water, which weighs 8.34 lbs. per USA gallon, conversion factors must be used when spraying liquids that are heavier or lighter than water. To determine the proper size nozzle for the liquid to be sprayed, first multiply the desired GPM or GPA of liquid by the water rate conversion factor. Then use the new converted GPM or GPA rate to select the proper size nozzle.

Example:

Desired application rate is 20 GPA of 28%N. Determine the correct nozzle size as follows:

$$\text{GPA (liquid other than water)} \times \text{Conversion Factor} = \text{GPA (from table in catalog)}$$

$$20 \text{ GPA (28\%)} \times 1.13 = 22.6 \text{ GPA (water)}$$

The applicator should choose a nozzle size that will supply 22.6 GPA of water at the desired pressure.

Weight of Solution	Specific Gravity	Conversion Factor
7.0 lbs./gal.	.84	.92
8.0 lbs./gal.	.96	.98
8.34 lbs./gal.	1.00 – WATER	1.00
9.0 lbs./gal.	1.08	1.04
10.0 lbs./gal.	1.20	1.10
10.65 lbs./gal.	1.28 – 28% nitrogen	1.13
11.0 lbs./gal.	1.32	1.15
12.0 lbs./gal.	1.44	1.20
14.0 lbs./gal.	1.68	1.30

Spray Coverage Information

This table lists the theoretical coverage of spray patterns as calculated from the included spray angle of the spray and the distance from the nozzle orifice. These values are based on the assumption that the spray angle remains the same throughout the entire spray distance. In actual practice, the tabulated spray angle does not hold for long spray distances.

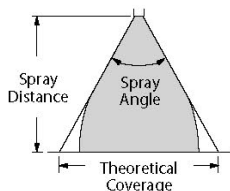

Included Spray Angle	Theoretical Coverage at Various Spray Heights (in Inches)							
	8"	10"	12"	15"	18"	24"	30"	36"
15°	2.1	2.6	3.2	3.9	4.7	6.3	7.9	9.5
20°	2.8	3.5	4.2	5.3	6.4	8.5	10.6	12.7
25°	3.5	4.4	5.3	6.6	8.0	10.6	13.3	15.9
30°	4.3	5.4	6.4	8.1	9.7	12.8	16.1	19.3
35°	5.0	6.3	7.6	9.5	11.3	15.5	18.9	22.7
40°	5.8	7.3	8.7	10.9	13.1	17.5	21.8	26.2
45°	6.6	8.3	9.9	12.4	14.9	19.9	24.8	29.8
50°	7.5	9.3	11.2	14.0	16.8	22.4	28.0	33.6
55°	8.3	10.3	12.5	15.6	18.7	25.0	31.2	37.5
60°	9.2	11.5	13.8	17.3	20.6	27.7	34.6	41.6
65°	10.2	12.7	15.3	19.2	22.9	30.5	38.2	45.8
73°	11.8	14.8	17.8	22.0	27.0	36.0	44.0	53.0
80°	13.4	16.8	20.2	25.2	30.3	40.3	50.4	60.4
85°	14.7	18.3	22.0	27.5	33.0	44.0	55.4	66.4
90°	16.0	20.0	24.0	30.0	36.0	48.0	60.0	72.0
95°	17.5	21.8	26.2	32.8	40.3	52.4	65.5	78.6
100°	19.1	23.8	28.6	35.8	43.0	57.2	71.6	85.9
110°	22.8	28.5	34.3	42.8	51.4	68.5	85.6	103
120°	27.7	34.6	41.6	52.0	62.4	83.2	104	
130°	34.3	42.9	51.5	64.4	77.3	103		
140°	43.8	54.8	65.7	82.2	98.6			
150°	59.6	74.5	89.5					

Nozzle Nomenclature

There are many types of nozzles available, with each providing different flow rates, spray angles, droplet sizes and patterns. Some of these spray tip characteristics are indicated by the tip number.

Remember, when replacing tips, be sure to purchase the same tip number, thereby ensuring your sprayer remains properly calibrated.

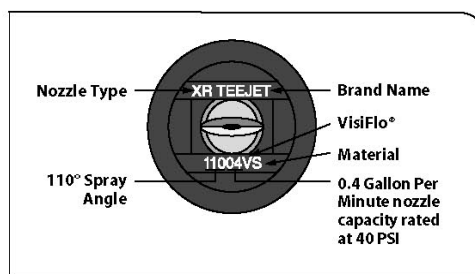

CALIBRATION / TECHNICAL INFORMATION

Information About Spray Pressure

Flow Rate

Nozzle flow rate varies with spraying pressure. In general, the relationship between GPM and pressure is as follows:

$$\frac{GPM_1}{GPM_2} = \frac{\sqrt{PSI_1}}{\sqrt{PSI_2}}$$

This equation is explained by the illustration to the right. Simply stated, in order to double the flow through a nozzle, the pressure must be increased four times.

Higher pressure not only increases the flow rate through a nozzle, but it also influences the droplet size and the rate of orifice wear. As pressure is increased, the droplet size decreases and the rate of orifice wear increases.

The values given in the tabulation sections of this catalog indicate the most commonly used pressure ranges for the associated spray tips. When information on the performance of spray tips outside of the pressure range given in this catalog is required, contact the Agricultural Division at Spraying Systems Co.®

Spray Angle and Coverage

Depending on the nozzle type and size, the operating pressure can have a significant effect on spray angle and quality of spray distribution. As shown here for an 11002 flat spray tip, lowering the pressure results in a smaller spray angle and a significant reduction in spray coverage.

Tabulations for spray tips in this catalog are based on spraying water. Generally, liquids with surface tensions lower than water will produce wider spray angles. In situations where the uniformity of spray distribution is important, be careful to operate your spray tips within the proper pressure range.

Note: Suggested minimum spray heights for broadcast spraying are based upon nozzles spraying water at the rated spray angle.

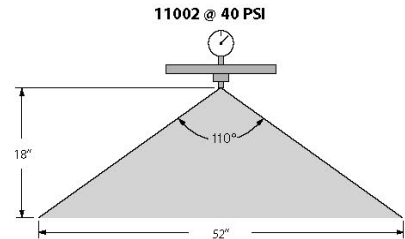
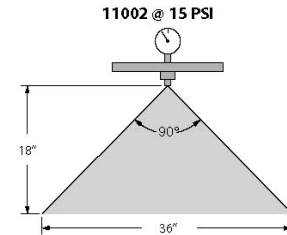
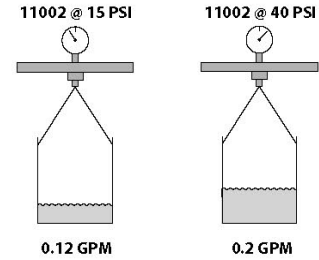

Pressure Drop Through Sprayer Components

Component Number	Typical Pressure Drop (PSI) at Various Flow Rates (GPM)									
	3 GPM	5 GPM	7 GPM	8 GPM	9 GPM	10 GPM	15 GPM	18 GPM	32 GPM	
AA2 GunJet®	2.0	5.3	10.0		16.0					
AA18 GunJet	5.0	13.0	25.0		40.0					
AA30L GunJet		14.0								
AA43 GunJet		1.0	2.0							
AA143 GunJet		0.9	1.7			3.5	7.9			
AA6B Valve		0.5	1.2	1.7	2.2	2.9	7.8	12.2		
AA17 Valve		1.5	2.5	3.5	4.0	5.0	11.5	16.0		
AA144A Valve		1.5	2.5	3.5	4.0	5.0	11.5	16.0		
AA144A-1-3 Valve				5.0						
AA145 Valve								5.0		
344BEC-24-C Valve									5.0	

Pressure Drop Through Various Hose Sizes

Flow in GPM	Pressure Drop in PSI (10 Ft. length without couplings)				
	¼" I.D.	⅜" I.D.	½" I.D.	¾" I.D.	1" I.D.
0.5	1.4	.2			
1.0		.7			
1.5		1.4	.4		
2.0		2.4	.6		
2.5		3.4	.9		
3.0			1.2		
4.0			2.0		
5.0			2.9	.4	
6.0			4.0	.6	
8.0				.9	.3
10.0				1.4	.4

CALIBRATION / TECHNICAL INFORMATION

Area Measurement

It is essential to know the amount of area that you intend to cover when applying a pesticide or fertilizer. Turf areas such as home lawns and golf course greens, tees and fairways should be measured in square feet or acres, depending upon the units needed.

Rectangular Areas



Area = Length (l) x Width (w)

Example:

What is the area of a lawn that is 300 feet long and 150 feet wide?

$$\begin{aligned} \text{Area} &= 300 \text{ feet} \times 150 \text{ feet} \\ &= 45,000 \text{ square feet} \end{aligned}$$

By using the following equation, it is possible to determine the area in acres.

$$\text{Area in acres} = \frac{\text{Area in square feet}}{43,560 \text{ sq. ft. per acre}}$$

(There are 43,560 square feet in an acre.)

Example:

$$\begin{aligned} \text{Area in acres} &= \frac{45,000 \text{ sq. ft.}}{43,560 \text{ sq. ft. per acre}} \\ &= 1.03 \text{ acres} \end{aligned}$$

Triangular Areas

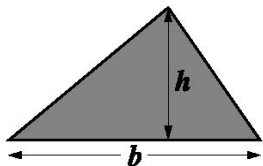

$$\text{Area} = \frac{\text{Base } (b) \times \text{Height } (h)}{2}$$

Example:

The base of a corner lot is 250 feet while the height is 50 feet. What is the area of the lot?

$$\begin{aligned} \text{Area} &= \frac{250 \text{ feet} \times 50 \text{ feet}}{2} \\ &= 6,250 \text{ square feet} \end{aligned}$$

$$\begin{aligned} \text{Area in acres} &= \frac{6,250 \text{ square feet}}{43,560 \text{ sq. ft. per acre}} \\ &= 0.14 \text{ acre} \end{aligned}$$

Circular Areas

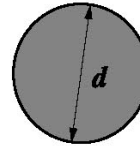

$$\text{Area} = \frac{\pi \times \text{Diameter}^2 (d)}{4}$$

$$\pi = 3.14159$$

Example:

What is the area of a green that has a diameter of 45 feet?

$$\begin{aligned} \text{Area} &= \frac{\pi \times (45 \text{ feet})^2}{4} = \frac{3.14 \times 2,025}{4} \\ &= 1,590 \text{ square feet} \end{aligned}$$

$$\begin{aligned} \text{Area in acres} &= \frac{1,590 \text{ square feet}}{43,560 \text{ sq. ft. per acre}} \\ &= 0.04 \text{ acre} \end{aligned}$$

Irregular Areas

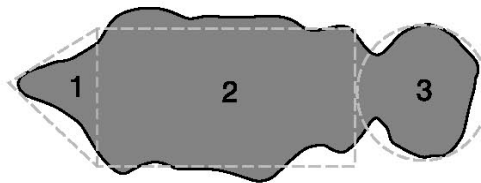

Any irregularly shaped turf area can usually be reduced to one or more geometric figures. The area of each figure is calculated and the areas are then added together to obtain the total area.

Example:

What is the total area of the Par-3 hole illustrated above?

The area can be broken into a triangle (area 1), a rectangle (area 2) and a circle (area 3). Then use the previously mentioned equations for determining areas to find the total area.

$$\text{Area 1} = \frac{25 \text{ feet} \times 30 \text{ feet}}{2} = 375 \text{ square feet}$$

$$\text{Area 2} = 25 \text{ feet} \times 475 \text{ feet} = 11,875 \text{ square feet}$$

$$\text{Area 3} = \frac{3.14 \times (45 \text{ feet})^2}{4} = 1,590 \text{ square feet}$$

$$\text{Total Area} = 375 + 11,875 + 1,590 = 13,840 \text{ square feet}$$

$$\begin{aligned} &= \frac{13,840 \text{ square feet}}{43,560 \text{ sq. ft. per acre}} = 0.32 \text{ acre} \end{aligned}$$

CALIBRATION / TECHNICAL INFORMATION

Sprayer Calibration

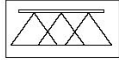

Broadcast Application

Sprayer calibration (1) **readies your sprayer for operation** and (2) **diagnoses tip wear**. This will give you optimum performance of your TeeJet® tips.

Equipment Needed:

- TeeJet Calibration Container
- Calculator
- TeeJet Cleaning Brush
- One new TeeJet Spray Tip matched to the nozzles on your sprayer
- Stopwatch or wristwatch with second hand

STEP NUMBER 1

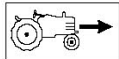

Check Your Tractor/Sprayer Speed!

Knowing your real sprayer speed is an essential part of accurate spraying. Speedometer readings and some electronic measurement devices can be inaccurate because of wheel slippage. Check the time required to move over a 100- or 200-foot strip on your field. Fence posts can serve as permanent markers. The starting post should be far enough away to permit your tractor/sprayer to reach desired spraying speed. Hold that speed as you travel between the "start" and "end" markers. Most accurate measurement will be obtained with the spray tank half full. Refer to the table on page 173 to calculate your real speed. When the correct throttle and gear settings are identified, mark your tachometer or speedometer to help you control this **vital** part of accurate chemical application.

STEP NUMBER 2

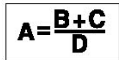

The Inputs

Before spraying, record the following:

	EXAMPLE
Nozzle type on your sprayer.	TT11004 Flat Spray Tip
<small>(All nozzles must be identical)</small>	
Recommended application volume20 GPA
<small>(From manufacturer's label)</small>	
Measured sprayer speed6 MPH
Nozzle spacing.20 Inches



STEP NUMBER 3

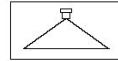

Calculating Required Nozzle Output

Determine GPM nozzle output from formula.

$$\text{FORMULA: } \text{GPM} = \frac{\text{GPA} \times \text{MPH} \times \text{W}}{5,940 \text{ (constant)}}$$

$$\text{EXAMPLE: } \text{GPM} = \frac{20 \times 6 \times 20}{5,940} = \frac{2,400}{5,940}$$

ANSWER: 0.404 GPM

STEP NUMBER 4



Setting the Correct Pressure

Turn on your sprayer and check for leaks or blockage. Inspect and clean, if necessary, all tips and strainers with TeeJet brush. Replace one tip and strainer **with an identical new tip and strainer** on sprayer boom.

Check appropriate tip selection table and determine the pressure required to deliver the nozzle output calculated from the formula in Step 3 for your new tip. Since all of the tabulations are based on spraying water, conversion factors must be used when spraying solutions that are heavier or lighter than water (see page 174).

Example: (Using above inputs) refer to TeeJet table on page 9 for TT11004 flat spray tip. The table shows that this nozzle delivers 0.40 GPM at 40 PSI.

Turn on your sprayer and adjust pressure. **Collect and measure the volume of the spray from the new tip for one minute in the collection jar.** Fine tune the pressure until you collect .40 GPM.

You have now adjusted your sprayer to the proper pressure. It will properly deliver the application rate specified by the chemical manufacturer at your measured sprayer speed.

STEP NUMBER 5



Checking Your System

Problem Diagnosis: Now, check the flow rate of a few tips on each boom section. If the flow rate of any tip is 10 percent greater or less than that of the newly installed spray tip, recheck the output of that tip. If only one tip is faulty, replace with new tip and strainer and your system is ready for spraying. However, if a second tip is defective, **replace all tips on the entire boom**. This may sound unrealistic, but two worn tips on a boom are ample indication of tip wear problems. Replacing only a couple of worn tips invites potentially serious application problems.

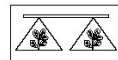

Banding and Directed Applications

The only difference between the above procedure and calibrating for banding or directed applications is the input value used for "W" in the formula in Step 3.

For single nozzle banding or boomless applications:

$$W = \text{Sprayed band width or swath width (in inches).}$$

For multiple nozzle directed applications:

$$W = \text{Row spacing (in inches) divided by the number of nozzles per row.}$$

CALIBRATION / TECHNICAL INFORMATION

Calibration/Adjustment Accessories



Water and Oil Sensitive Paper

These specially coated papers are used for evaluating spray distributions, swath widths, droplet densities and penetration of spray. Water sensitive paper is yellow and is stained blue by exposure to aqueous spray droplets. White oil sensitive paper turns black in areas exposed to oil droplets. For more information on water sensitive paper write for data sheet 20301; for information on oil sensitive paper write for data sheet 20302.

Water and oil sensitive paper sold by Spraying Systems Co. is manufactured by Syngenta Crop Protection AG.

Water Sensitive Paper		
Part Number	Paper Size	Quantity/Package
20301-1N	3" x 1"	50 cards
20301-2N	3" x 2"	50 cards
20301-3N	20" x 1"	25 strips

Oil Sensitive Paper		
Part Number	Paper Size	Quantity/Package
20302-1	3" x 2"	50 cards

How to order:

Add the prefix 'SP' to the above listed part numbers.

TeeJet Tip Cleaning Brush

Part No:
SP20016



TeeJet® Tip Tester

The TeeJet Tip Tester helps identify worn spray tips quickly and easily. This handheld flowmeter allows you to check all spray tips for uniform flow rates in minutes. Just attach the adapter over a spray tip and read the approximate flow rate directly from the dual measurement scale. An adapter is provided to fit all types of conventional and quick-attach nozzle caps. Each tip tester is supplied with a TeeJet nozzle cleaning brush in the built-in storage compartment.

How to order:

Part No:
SP37670

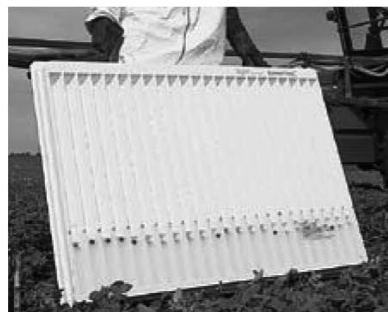

TeeJet Pattern Check

Successful applications depend on a quality pattern from your spray tips and proper operation of your spraying equipment. The TeeJet Pattern Check makes it easy to see if your sprayer is properly set up to provide the even distribution needed for safe and effective pest control. By sliding the pattern check under the sprayer boom while spraying clean water, you get an immediate indication of the spray distribution along the boom.

How to order:

Part No:
SP37685

TeeJet Calibration Container

The TeeJet Calibration Container features a 68 oz. (2.0 L) capacity and a raised dual scale in both U.S. and metric graduations. The container is molded of polypropylene for excellent chemical resistance and durability.

How to order:

Part No:
SP24034



TeeJet 38560 Wind Meter

- Measures wind velocity on three scales: Beaufort, MPH (miles per hour) and m/sec (meters per second).

- Wide wind velocity range.

- Compact and lightweight for convenient transport and storage.

- Easy to operate and maintain.

How to order:

Part No:
SP38560



Greenleaf Technologies Digital Windmeter

Part No:
GTWM10

Greenleaf Technologies Calibration Calculator

Part No:
GTQC02



CALIBRATION / TECHNICAL INFORMATION

Spray Tip Wear

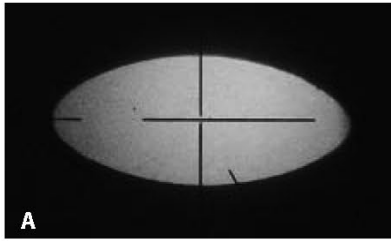

Tips Don't Last Forever!

There is sufficient evidence that spray tips may be the most neglected component in today's farming. Even in countries with obligatory sprayer testing, spray tips are the most significant failure. On the other hand, they are among the most critical of items in proper application of valuable agricultural chemicals.

For example, a 10 percent over-application of chemical on a twice-sprayed 1,000-acre farm could represent a loss of \$2,000-\$10,000 based on today's chemical investments of \$10.00-\$50.00 per acre. This does not take into account potential crop damage.

Spray Tip Care is the First Step to Successful Application

The successful performance of a crop chemical is highly dependent on its proper application as recommended by the chemical manufacturer. Proper selection and operation of spray nozzles are very important steps in accurate chemical application. The volume of spray passing through each nozzle plus the droplet size and spray distribution on the target can influence pest control.

Critical in controlling these three factors is the spray nozzle orifice. Careful craftsmanship

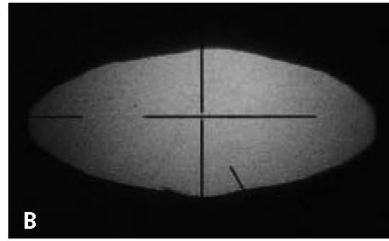
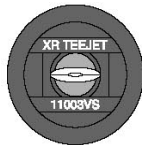

An Inside Look at Nozzle Orifice Wear and Damage

While wear may not be detected when visually inspecting a nozzle, it can be seen when viewed through an optical comparator. The edges of the worn nozzle (B) appear more rounded than the edges of the new nozzle (A). Damage to nozzle (C) was caused by improper cleaning. The spraying results from these tips can be seen in the illustrations below.

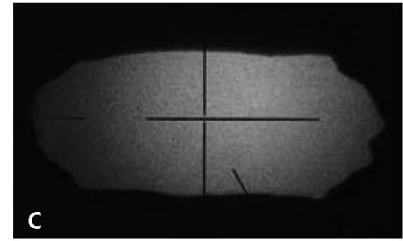

Determining Tip Wear

The best way to determine if a spray tip is excessively worn is to compare the flow rate from the used tip to the flow rate of a new tip of the same size and type. Charts in this catalog indicate the flow rates for new nozzles. Check the flow of each tip by using an accurate graduated collection container, a timing device and an accurate pressure gauge mounted at the nozzle tip. Compare the flow rate of the old tip to that of the new one. Spray tips are considered excessively worn and should be replaced when their flow exceeds the flow of a new tip by 10%. Reference page 177 for more information.

goes into the precision manufacturing of each nozzle orifice. European standards, for example the BBA, require very small flow tolerances (+/-5%) of nominal flow. Many TeeJet nozzle types and sizes are already BBA-approved, which confirms the high quality standard designed into TeeJet nozzles. To maintain the quality in practical spraying as long as possible, the operator's job is the proper maintenance of those spray tips.

The illustration below compares the spraying results obtained from well-maintained vs. poorly-maintained spray tips. Poor spray distribution can be prevented. Selection of longer wearing tip materials or frequent replacement of tips from softer materials can eliminate misapplication due to worn spray tips.

Careful cleaning of a clogged spray tip can mean the difference between a clean field and one with weed streaks. Flat spray tips have finely crafted thin edges around the orifice to control the spray. Even the slightest damage from improper cleaning can cause both an increased flow rate and poor spray distribution. Be sure to use adequate strainers in your spray system to minimize clogging. If a tip does clog, only use a soft bristled brush or toothpick to clean it – never use a metal object. Use extreme care with soft tip materials such as plastic. Experience has shown that even a wooden toothpick can distort the orifice.

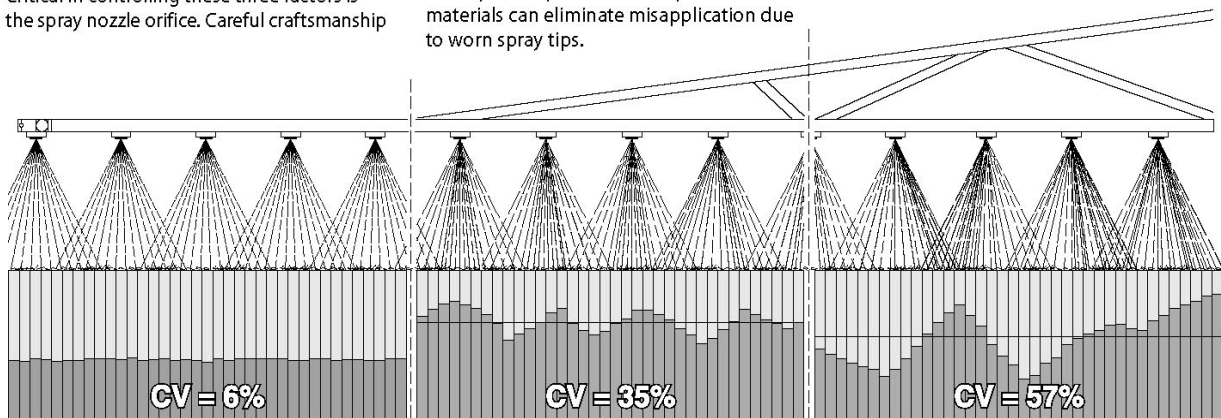

NEW SPRAY TIPS
Produce a uniform distribution when properly overlapped.

WORN SPRAY TIPS
Have a higher output with more spray concentrated under each tip.

DAMAGED SPRAY TIPS
Have a very erratic output – overapplying and underapplying.

CALIBRATION / TECHNICAL INFORMATION

Spray Distribution Quality

One of the most overlooked factors that can dramatically influence the effectiveness of a given crop production chemical is spray distribution. The uniformity of the spray distribution across the boom or within the spray swath is an essential component to achieving maximum chemical effectiveness with minimal cost and minimal non-target contamination. This is more than critical if carrier and chemical rates are applied at the recommended minimum rate. There are many other factors influencing a crop production chemical's effectiveness, such as weather, application timing, active ingredient rates, pest infestation, etc. However, an operator must become aware of spray distribution quality if maximum efficiency is expected.

Measurement Techniques

Spray distribution can be measured in different ways. Spraying Systems Co.[®], and some sprayer manufacturers, as well as other research and testing stations, have patternators (spray tables) that collect the spray from nozzles on a standardized or real boom. These patternators have a number of channels aligned perpendicular to the nozzle spray. The channels carry the spray liquid into vessels for measuring and analysis (see photo with TeeJet patternator). Under controlled conditions, very accurate distribution measurements can be made for nozzle evaluation and development. Distribution measurements can also take place on an actual farm sprayer. For static measurements along the sprayer boom, a patternator equal or very similar to the one described earlier is placed under

the boom in a stationary position or as a small patternator unit scanning the whole boom up to a width of 50 m. Any system of patternator measures electronically the quantity of water in each channel and calculates the values. A distribution quality test gives the applicator important information about the state of the nozzles on the boom. When much more detailed information about spray quality and coverage is required, a dynamic system—spraying a tracer (dye)—can be used. The same is true if the distribution within the swath on a boom has to be measured. Currently, only a few test units worldwide have the ability to perform a stationary test. These tests usually involve shaking or moving the spray boom to simulate actual field and application conditions.

Most of the distribution measuring devices result in data points representing the sprayer's boom swath uniformity. These data points can be very revealing just through visual observation. However, for comparison reasons, a statistical method is widely accepted. This method is Coefficient of Variation (Cv). The Cv compiles all the patternator data points and summarizes them into a simple percentage, indicating the amount of variation within a given distribution. For extremely uniform distributions under accurate conditions, the Cv can be $\leq 7\%$. In some European countries, nozzles must conform to very strict Cv specifications, while other countries may require the sprayer's distribution to be tested for uniformity every one or two years. These types of stipulations emphasize the great importance of distribution quality and its effect on crop production effectiveness.

Factors Affecting Distribution

There are a number of factors contributing to the distribution quality of a spray boom or resulting Cv percentage. During a static measurement, the following factors can significantly affect the distribution.

- Nozzles
 - type
 - pressure
 - spacing
 - spray angle
 - offset angle
 - spray pattern quality
 - flow rate
 - overlap
- Boom Height
- Worn Nozzles
- Pressure Losses
- Plugged Filters
- Plugged Nozzles
- Plumbing Factors Influencing Liquid Turbulence at Nozzle

Additionally, in the field during the spraying application or during a dynamic distribution test, the following can influence the distribution quality:

- Boom Stability
 - vertical movement (pitch)
 - horizontal movement (yaw)
- Environmental Conditions
 - wind velocity
 - wind direction
- Pressure Losses (sprayer plumbing)
- Sprayer Speed and Resulting Turbulence

The effect of distribution uniformity on the efficiency of a crop production chemical can vary under different circumstances. The crop production chemical itself can have dramatic influence over its efficiency. Always consult the manufacturer's chemical label or recommendation before spraying.



CALIBRATION / TECHNICAL INFORMATION

Droplet Size and Drift Information

A nozzle's spray pattern is made up of numerous spray droplets of varying sizes. Droplet size refers to the diameter of an individual spray droplet.

Since most nozzles have a wide distribution of droplet sizes (otherwise known as droplet spectrum), it is useful to summarize this with statistical analysis. Most advanced drop size measuring devices are automated, using computers and high-speed illumination sources such as lasers to analyze thousands of droplets in a few seconds. Through statistics, this large volume of data can be reduced to a single number that is representative of the drop sizes contained in the spray pattern and can then be classified into droplet size classes. These classes (very fine, fine, medium, coarse, very coarse,

and extremely coarse) can then be used to compare one nozzle to another. Care must be taken when comparing one nozzle's drop size to another, as the specific testing procedure and instrument can bias the comparison.

Droplet sizes are usually measured in microns (micrometers). One micron equals 0.001 mm. The micron is a useful unit of measurement because it is small enough that whole numbers can be used in drop size measurement.

The majority of agricultural nozzles can be classified as producing either fine, medium, coarse or very coarse droplets. A nozzle with a coarse or very coarse droplet is usually selected to minimize off-target spray drift, while a nozzle with a fine droplet

is required to obtain maximum surface coverage of the target plant.

To show comparisons between nozzle types, spray angle, pressure and flow rate, refer to the droplet size classes shown in the tables on pages 182-183.

Another droplet size measurement that is useful for determining a nozzle's drift potential is the percentage of driftable fines. Since the smaller droplets have a greater tendency to move off-target, it makes sense to determine what the percentage of small droplets is for a particular nozzle in order to minimize it when drift is a concern. Droplets below 200 microns are considered potential drift contributors. The table below shows several nozzles and their percentage of driftable fines.

Spraying Systems Co.[®] uses the most advanced measuring instrumentation (PDPA and Oxford lasers) to characterize sprays, obtaining droplet size and other important information. For the latest accurate information about nozzles and their droplet size, please contact your nearest TeeJet representative.



Driftable Droplets*

Nozzle Type (0.50 GPM Flow)	Approximate Percent of Spray Volume Less Than 200 Microns	
	15 PSI	40 PSI
XR TeeJet [®] 110°	14%	22%
XR TeeJet 80°	6%	12%
DG TeeJet [®] 110°	N/A	11%
DG TeeJet 80°	N/A	7%
TT – Turbo TeeJet [®]	<1%	<6%
TF – Turbo FloodJet [®]	<1%	<1%
AI TeeJet [®] 110°	N/A	<1%

*Data obtained by spraying water at room temperature under laboratory conditions.

CALIBRATION / TECHNICAL INFORMATION

Drop Size Classification

Nozzle selection is often based upon droplet size. The droplet size from a nozzle becomes very important when the efficacy of a particular plant protection chemical is dependent on coverage, or the prevention of spray leaving the target area is a priority.

The majority of the nozzles used in agriculture can be classified as producing either fine, medium, coarse, or very coarse droplets. Nozzles that produce fine droplets are usually recommended for post-emergence applications, which require excellent coverage on the intended target area. The most common nozzles used in agriculture are those that produce medium-sized droplets. Nozzles producing medium- and

coarse-sized droplets can be used for contact and systemic herbicides, pre-emergence surface-applied herbicides, insecticides and fungicides.

An important point to remember when choosing a spray nozzle that produces a droplet size in one of the six categories is that one nozzle can produce different droplet size classifications at different pressures. A nozzle might produce medium droplets at low pressures, while producing fine droplets as pressure is increased.

Droplet size classes are shown in the following tables to assist in choosing an appropriate spray tip.

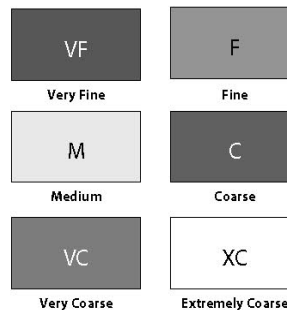

Droplet size classifications are based on BCPC specifications and in accordance with ASAE Standard S-572 at the date of printing. Classifications are subject to change.

Turbo TeeJet® (TT) and Turbo TeeJet® Duo (QJ90-2XTT)

	PSI										
	15	20	25	30	35	40	50	60	70	80	90
TT11001 QJ90-2XTT11001	C	M	M	M	M	M	F	F	F	F	F
TT110015 QJ90-2XTT110015	C	C	M	M	M	M	M	M	F	F	F
TT11002 QJ90-2XTT11002	C	C	C	M	M	M	M	M	M	M	F
TT110025 QJ90-2XTT110025	VC	C	C	C	M	M	M	M	M	M	F
TT11003 QJ90-2XTT11003	VC	VC	C	C	C	C	M	M	M	M	M
TT11004 QJ90-2XTT11004	XC	VC	VC	C	C	C	C	C	M	M	M
TT11005 QJ90-2XTT11005	XC	VC	VC	VC	VC	C	C	C	C	M	M
TT11006 QJ90-2XTT11006	XC	XC	VC	VC	VC	C	C	C	C	C	M
TT11008 QJ90-2XTT11008	XC	XC	VC	VC	VC	VC	C	C	C	C	M

AI TeeJet® (AI) and AIC TeeJet® (AIC)

	PSI											
	30	35	40	45	50	55	60	70	80	90	100	115
AI110015	VC	VC	VC	VC	VC	C	C	C	C	C	C	C
AI11002	VC	VC	VC	VC	VC	VC	VC	C	C	C	C	C
AI110025	VC	VC	VC	VC	VC	VC	VC	VC	C	C	C	C
AI11003	XC	XC	VC	VC	VC	VC	VC	VC	VC	C	C	C
AI11004	XC	XC	XC	VC	VC	VC	VC	VC	VC	C	C	C
AI11005	XC	XC	XC	VC	VC	VC	VC	VC	VC	VC	C	C
AI11006	XC	XC	XC	XC	VC	VC	VC	VC	VC	VC	C	C
AI11008	XC	XC	XC	XC	XC	VC	VC	VC	VC	VC	VC	C
AI11010	XC	XC	XC	XC	XC	VC	VC	VC	VC	VC	VC	C

Turbo TwinJet® (TTJ60)

	PSI										
	15	20	25	30	35	40	50	60	70	80	90
TTJ60-11002	VC	C	C	C	C	C	M	M	M	M	M
TTJ60-110025	XC	VC	C	C	C	C	C	C	M	M	M
TTJ60-11003	XC	VC	C	C	C	C	C	C	C	M	M
TTJ60-11004	XC	VC	C	C	C	C	C	C	C	C	M
TTJ60-11005	XC	VC	C	C	C	C	C	C	C	C	C
TTJ60-11006	XC	XC	VC	VC	C	C	C	C	C	C	C

Turbo TeeJet® Induction (TTI)

	PSI												
	15	20	25	30	35	40	50	60	70	80	90	100	
TTI110015	XC	XC	XC	XC	XC	XC	XC	XC	XC	XC	XC	XC	
TTI11002	XC	XC	XC	XC	XC	XC	XC	XC	XC	XC	XC	XC	
TTI110025	XC	XC	XC	XC	XC	XC	XC	XC	XC	XC	XC	XC	
TTI11003	XC	XC	XC	XC	XC	XC	XC	XC	XC	XC	XC	XC	
TTI11004	XC	XC	XC	XC	XC	XC	XC	XC	XC	XC	XC	XC	
TTI11005	XC	XC	XC	XC	XC	XC	XC	XC	XC	XC	XC	XC	
TTI11006	XC	XC	XC	XC	XC	XC	XC	XC	XC	XC	XC	XC	

CALIBRATION / TECHNICAL INFORMATION

XR TeeJet® (XR) and XRC TeeJet® (XRC)

	PSI						
	15	20	25	30	40	50	60
XR8001	M	F	F	F	F	F	F
XR80015	M	M	M	F	F	F	F
XR8002	M	M	M	M	F	F	F
XR8003	M	M	M	M	M	M	F
XR8004	C	C	M	M	M	M	M
XR8005	C	C	C	C	M	M	M
XR8006	C	C	C	C	C	C	C
XR8008	VC	VC	VC	C	C	C	C
XR11001	F	F	F	F	F	VF	VF
XR110015	F	F	F	F	F	F	F
XR11002	M	F	F	F	F	F	F
XR110025	M	M	F	F	F	F	F
XR11003	M	M	M	F	F	F	F
XR11004	M	M	M	M	M	F	F
XR11005	M	M	M	M	M	M	F
XR11006	C	C	M	M	M	M	M
XR11008	C	C	C	C	C	M	M

TeeJet® (TP)

	PSI				
	30	35	40	50	60
TP8001	F	F	F	F	F
TP80015	F	F	F	F	F
TP8002	M	M	F	F	F
TP8003	M	M	M	M	F
TP8004	M	M	M	M	M
TP8005	C	M	M	M	M
TP8006	C	C	C	C	C
TP8008	C	C	C	C	C
TP11001	F	F	F	VF	VF
TP110015	F	F	F	F	F
TP11002	F	F	F	F	F
TP11003	F	F	F	F	F
TP11004	M	M	M	F	F
TP11005	M	M	M	M	F
TP11006	M	M	M	M	M
TP11008	C	C	C	M	M

TurfJet® (TTJ)

	PSI				
	30	40	50	60	70
1/4TTJ02-VS	XC	XC	XC	XC	XC
1/4TTJ04-VS	XC	XC	XC	XC	XC
1/4TTJ05-VS	XC	XC	XC	XC	XC
1/4TTJ06-VS	XC	XC	XC	XC	XC
1/4TTJ08-VS	XC	XC	XC	XC	XC
1/4TTJ10-VS	XC	XC	XC	XC	XC
1/4TTJ15-VS	XC	XC	XC	XC	XC

Turbo FloodJet® (TF)

	PSI				
	10	15	20	30	40
TF-2	XC	XC	XC	XC	XC
TF-2.5	XC	XC	XC	XC	XC
TF-3	XC	XC	XC	XC	XC
TF-4	XC	XC	XC	XC	XC
TF-5	XC	XC	XC	XC	XC
TF-7.5	XC	XC	XC	XC	XC
TF-10	XC	XC	XC	XC	XC

DG TwinJet® (DG-TJ60)

	PSI				
	30	35	40	50	60
DGTJ60-110015	F	F	F	F	F
DGTJ60-11002	M	M	M	F	F
DGTJ60-11003	C	M	M	M	M
DGTJ60-11004	C	C	C	C	M
DGTJ60-11006	C	C	C	C	C
DGTJ60-11008	C	C	C	C	C

TwinJet® (TJ)

	PSI				
	30	35	40	50	60
TJ60-6501	F	VF	VF	VF	VF
TJ60-650134	F	F	F	VF	VF
TJ60-6502	F	F	F	F	F
TJ60-6503	M	F	F	F	F
TJ60-6504	M	M	M	M	F
TJ60-6506	M	M	M	M	M
TJ60-6508	C	C	C	M	M
TJ60-8001	VF	VF	VF	VF	VF
TJ60-8002	F	F	F	F	F
TJ60-8003	F	F	F	F	F
TJ60-8004	M	M	F	F	F
TJ60-8005	M	M	M	F	F
TJ60-8006	M	M	M	M	M
TJ60-8008	C	M	M	M	M
TJ60-8010	C	C	C	M	M
TJ60-11002	F	VF	VF	VF	VF
TJ60-11003	F	F	F	F	F
TJ60-11004	F	F	F	F	F
TJ60-11005	M	M	M	F	F
TJ60-11006	M	M	M	F	F
TJ60-11008	M	M	M	M	M
TJ60-11010	M	M	M	M	M

DG TeeJet® (DG E)

	PSI				
	30	35	40	50	60
DG95015E	M	M	M	F	F
DG9502E	M	M	M	M	M
DG9503E	C	M	M	M	M
DG9504E	C	C	C	M	M
DG9505E	C	C	C	M	M

DG TeeJet® (DG)

	PSI				
	30	35	40	50	60
DG80015	M	M	M	M	F
DG8002	M	M	M	M	M
DG8003	C	M	M	M	M
DG8004	C	C	C	M	M
DG8005	C	C	C	M	M
DG110015	M	M	F	F	F
DG11002	M	M	M	M	M
DG11003	C	M	M	M	M
DG11004	C	C	M	M	M
DG11005	C	C	C	M	M

CALIBRATION / TECHNICAL INFORMATION

Drift Causes and Control



Figure 1. This is not what crop protection should look like!

When applying crop protection chemicals, spray drift is a term used for those droplets containing the active ingredients that are not deposited on the target area. The droplets most prone to spray drift are usually small in size, less than 200 μm micron in diameter and easily moved off the target area by wind or other climatic conditions. Drift can cause crop protection chemicals to be deposited in undesirable areas with serious consequences, such as:

- Damage to sensitive adjoining crops.
- Surface water contamination.
- Health risks for animals and people.
- Possible contamination to the target area and adjacent areas or possible over-application within the target area.

Causes of Spray Drift

A number of variables contribute to spray drift; these are predominantly due to the spray equipment system and meteorological factors.

■ Droplet Size

Within the spray equipment system, drop size is the most influential factor related to drift.

When a liquid solution is sprayed under pressure it is atomized into droplets of varying sizes: **The smaller the nozzle size and the greater the spray pressure, the smaller the droplets and therefore the greater the proportion of driftable droplets.**

■ Spray Height

As the distance between the nozzle and the target area increases, the greater impact wind velocity can have on drift. The influence of wind can increase the proportion of smaller drops being carried off target and considered drift.

Do not spray at greater heights than those recommended by the spray tip manufacturer, while taking care not to spray below the minimum recommended heights.

■ Operating Speed

Increased operating speeds can cause the spray to be diverted back into upward wind currents and vortexes behind the sprayer, which trap small droplets and can contribute to drift.

Apply crop protection chemicals according to good, professional practices at maximum operating speeds of 4 to 6 mph (with air induction type nozzles—up to 6 mph). As wind velocities increase, reduce operating speed.*

* Liquid fertilizer applications using the TeeJet* tips with very coarse droplets can be performed at higher operating speeds.

■ Wind Velocity

Among the meteorological factors affecting drift, wind velocity has the greatest impact. Increased wind speeds cause increased spray drift. It is common knowledge that in most parts of the world the wind velocity is variable throughout the day (see Figure 2). Therefore, it is important for spraying to take place during the relatively calm hours of the day. The early morning and early evening are usually the most calm. **Refer to chemical label for velocity recommendations.**

When spraying with traditional techniques the following rules-of-thumb apply:

In low wind velocity situations, spraying can be performed at recommended nozzle pressures.

As wind velocities increase up to 17 mph, spray pressure should be reduced and nozzle size increased to obtain larger droplets that are less prone to drift. Wind measurements should be taken throughout the spraying operation with a wind meter or anemometer. As the risk of spray drift increases, selecting designed to more coarse droplets that are less prone to drift is extremely important. Some such TeeJet nozzles that fit into this category are: DG TeeJet®, Turbo TeeJet®, AI TeeJet®, Turbo TeeJet® Induction, and AIXR TeeJet®.

When wind velocities exceed 5 m/s, spraying operation should not be performed.

■ Air Temperature and Humidity

In ambient temperatures over 77°F/25°C with low relative humidity, small droplets are especially prone to drift due to the effects of evaporation.

High temperature during the spraying application may necessitate system changes, such as nozzles that produce a coarser droplet or suspending spraying.

■ Crop Protection Chemicals and Carrier Volumes

Before applying crop protection chemicals, the applicator should read and follow all instructions provided by the manufacturer. Since extremely low carrier volume usually necessitates the use of small nozzle sizes, the drift potential is increased. As high a carrier volume as practical is recommended.

Application Regulations for Spray Drift Control

In several European countries, regulatory authorities have issued application regulations in the use of crop protection chemicals to protect the environment. In order to protect the surface waters and the field buffer areas (examples are: hedges and grassy areas of a certain width) distance requirements must be kept because of spray drift. Inside the European Union (EU) there is a directive for the harmonization of crop protection chemicals in regards to environmental protection. In this respect the procedures that have been implemented in Germany, England and the Netherlands will be established in other EU countries in the coming years.

To reach the objectives for environmental protection, spray drift reducing measures have been integrated as a central instrument in the practice of risk evaluation. For example, buffer zones may be reduced in width if certain spraying techniques or equipment is used that have been approved and certified by certain regulatory agencies. Many of the TeeJet nozzles designed for reducing spray drift have been approved and certified in several EU countries. The certification of those registrars fits into a drift reduction category, such as 90%, 75%, or 50% (90/75/50) control of drift. This rating is related to the comparison of the BCPC reference nozzle capacity of 03 at 3 bar.

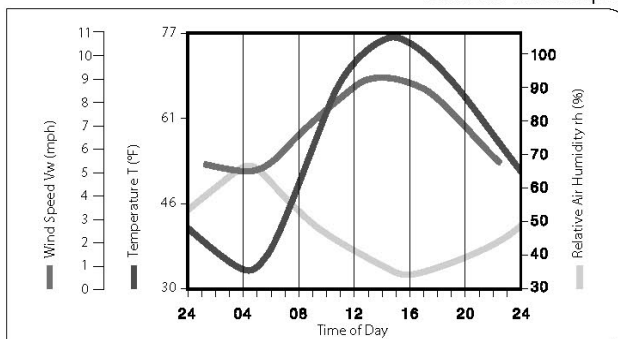

Figure 2. Development of wind velocity, air temperature and relative air humidity (example). From: Malberg

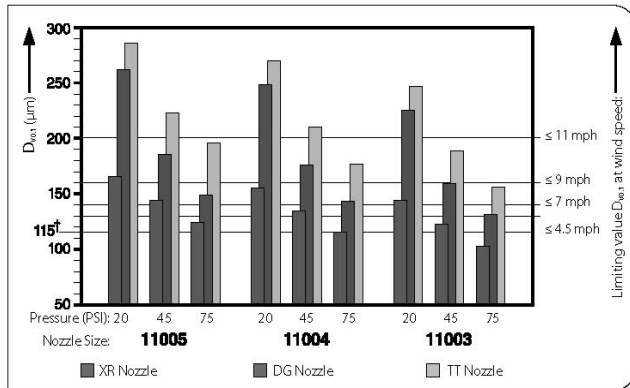

Figure 3. $D_{50.1}$ for XR, DG and TT nozzles with lower limits of 10% DV for various wind speeds.

$tD_{50.1}$ of the XR11002 at 36 PSI.

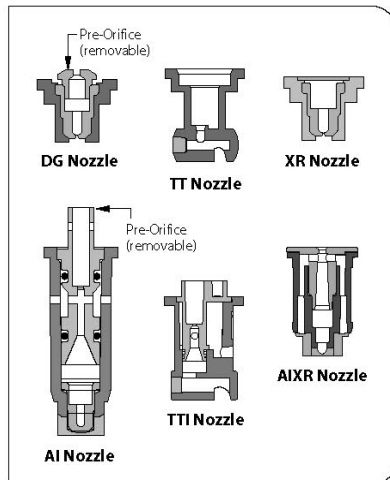

Figure 4. XR, DG, TT, TTI, AI and AIXR Nozzles (section).

Nozzles for Spray Drift Control

Drift potential can be minimized even when it is necessary to use small size nozzles by selecting the appropriate style. Nozzles such as the Turbo TeeJet® (TT), Air Induction TeeJet® (AI) and the Drift Guard TeeJet® (DG) produce medium to coarse sprays even in the smaller sizes. Large size droplets are much less susceptible to drift, but in some cases target coverage may be reduced due to a reduction in the number of drops. This needs to be taken into account, especially when using contact crop protection chemicals.

Wide angle flat spray nozzles with pre-orifice technology can achieve a larger drop size range at equal pressures without a reduction in flow rate. The DG, AI, TT, TTI, and AIXR incorporate pre-orifice technology, which performs the primary flow metering function. The larger exit orifice provides secondary metering and pattern formation (see Figure 4).

Venturi-type nozzles, such as the AI, TTI, and AIXR, use a pre-orifice to create a high-velocity liquid stream and then draw air into the stream through a side opening. This mixture of air and liquid is then discharged at a low exit velocity thus creating very coarse droplets with air inclusion. However, air-filled droplets only occur with chemicals containing a sufficient concentration of surfactants.

Figure 5 demonstrates the difference in droplet sizes between the TeeJet XR, DG and TT nozzles on the basis of VMD. From this figure, the following conclusions can be drawn:

- The DG nozzle in comparison to the XR achieves 30% higher VMD values. However, as the pressure increases, the percentage difference decreases.
- The TT nozzle achieves about 10–20% higher VMD values than the DG at equal pressures.
- The VMD values for the TT nozzle at 15 PSI pressure is about 70% higher than the XR.

Summary

Drift can be managed successfully with the right knowledge of the equipment and the factors influencing drift. Every application must be balanced between managing drift and maintaining effective crop protection. Below is a list of factors that must be considered to ensure a safe, accurate spray application.

- Spray Pressure
- Nozzle Size
- Application Rate
- Spray Nozzle Height
- Operating Speed
- Wind Velocity
- Air Temperature and Relative Humidity
- Buffer Zones (safe distances from sensitive areas)
- Instructions from the Crop Protection Chemical Manufacturer

Having taken into account all the variables that can have an impact on the drift potential, it may still be necessary to consider the use of drift control nozzles, such as the AI, TTI, or AIXR.

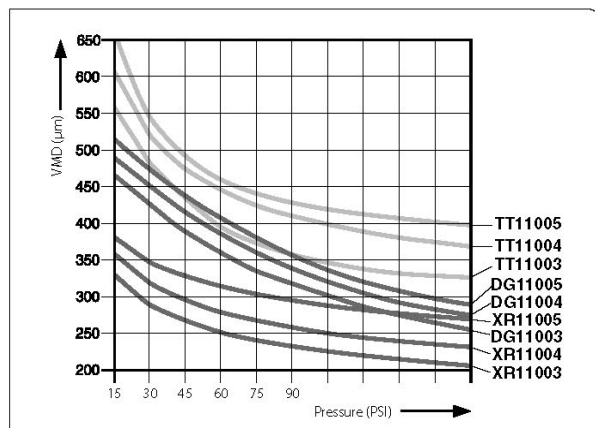

Figure 5. VMD achieved by XR, DG and TT nozzles relative to pressure.

Measurement conditions:
 - Laser-Doppler Test
 - Continuous PDPA measurement over entire flat spray width (PDPA)
 - Distance 20 inches (measured along spray tip axis)
 - Water temperature 70°F

CALIBRATION / TECHNICAL INFORMATION

Drift Measurement Systems

In an effort to meet the requirements of buffer zone reductions in certain European countries, Spraying Systems Co.[®] conducts rigorous distribution and drift testing of its line of TeeJet[®] nozzles by prominent European research institutions. The Silsoe Research

Institute in the United Kingdom and the Federal Biological Research Center for Agriculture and Forestry in Germany are two of the independent testing institutions commonly used by Spraying Systems Co.

¹Local Environment Risk Assessments for Pesticides (LERAP)

LERAP requirements relate to the ability to reduce the width of a buffer zone defined to protect surface water from contamination by plant protection products when the results from a local risk assessment indicate that it is safe to do so. One of the factors that is taken into account as part of the LERAP assessment is the use of technical (operational and engineering) controls to reduce the amount of spray drift produced during an application that would be deposited within the local environment. Spray application systems that have been shown to have such a drift-reducing characteristic will be awarded a "LERAP-Low Drift Star Rating," which can then be used in the local drift risk assessment procedures.

Star ratings are awarded by comparing the levels of drift from TeeJet spray tips with corresponding drift levels from a reference system. Drift assessment is conducted in a wind tunnel using water and a 0.1% solution of non-ionic surfactant for both the reference and test nozzles at a height of 209 (0.5 m).

The TeeJet spray tips gaining accreditation were tested under the prescribed protocol by Silsoe Research Institute, Wrest Park, Silsoe, Bedford, MK45 4HS UK, and then sent on to be accredited by another approved laboratory, in this case Central Science Laboratory, Sand Hutton, York, YO41 1LZ UK.

Full details about LERAP and its accreditation procedures can be obtained from http://www.pesticides.gov.uk/fg_leraps.asp.

Federal Biological Research Center for Agriculture and Forestry (BBA)

The Department for Plant Protection Products and Application Techniques, a Department of the German BBA.

² In Germany, the buffer zones in arable crops, orchards, vineyards or hops are dependent on application conditions. A special system measuring the Drift Potential Index (DXI) takes into account the type of adjacent water body and its bank vegetation. The application technique used has the main influence on the buffer zone width.

With the application for certification as loss reducing equipment, the sprayer manufacturer has to supply test results that prove drift reduction. In the case of ordinary boom sprayers, measurements in a wind tunnel on single nozzles are sufficient. These tests are done by the BBA following a special protocol.

The TeeJet spray tips gaining accreditation were tested under the prescribed protocol by The Department for Plant Protection Products and Application Techniques, Biologische Bundesanstalt für Land-und Forstwirtschaft, Messeweg 11/12, D – 38104 Braunschweig, Germany. Full details about BBA and its accreditation procedures can be obtained from <http://www.BBA.de>.

² Herbst, A. 2001. A Method to Determine Spray Drift Potential from Nozzles and its Link to Buffer Zone Restrictions. ASAE Meeting Paper No. 01-1047. St. Joseph, Mich.: ASAE

Table 1
Definition of LERAP-Low Drift Star Ratings

Terminology	Drift Performance (measurable as ground deposit)
No LERAP-Low Drift rating	Drift levels greater than 75% of that from reference system.
LERAP-Low Drift-one star*	Drift levels greater than 50% and up to 75% of that from reference system.
LERAP-Low Drift-two star**	Drift levels greater than 25% and up to 50% of that from reference system.
LERAP-Low Drift-three star***	Drift levels up to 25% of that from reference system.

Disclaimer: This information is subject to change.

¹ Pesticides Safety Directorate. 07 August 2002. http://www.bba.bund.de/cdn_045/DE/Home/homepage_node.html_nnn=true



CALIBRATION / TECHNICAL INFORMATION

Plumbing Diagrams

The following diagrams have been developed to serve as a guideline for plumbing agricultural sprayers. Similar manual valves may be substituted for electric valves. However, the sequence in which these valves occur should remain the same. Note that one of the most common causes of premature valve failure is improper installation.

Positive Displacement Pump

Piston, roller and diaphragm pumps are all types of positive displacement pumps. This means that pump output is proportional to speed and virtually independent of pressure. A key component in a positive displacement system is the pressure relief valve. Proper placement and sizing of the pressure relief valve is essential for safe and accurate operation of a positive displacement pump.

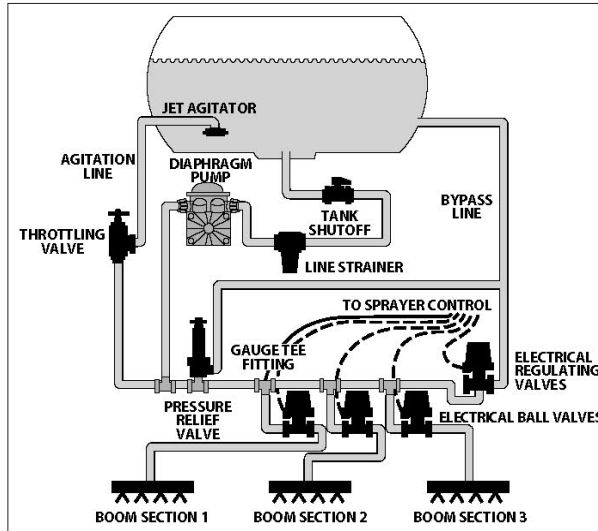

Two-Way Plumbing Diagram (Positive Displacement)

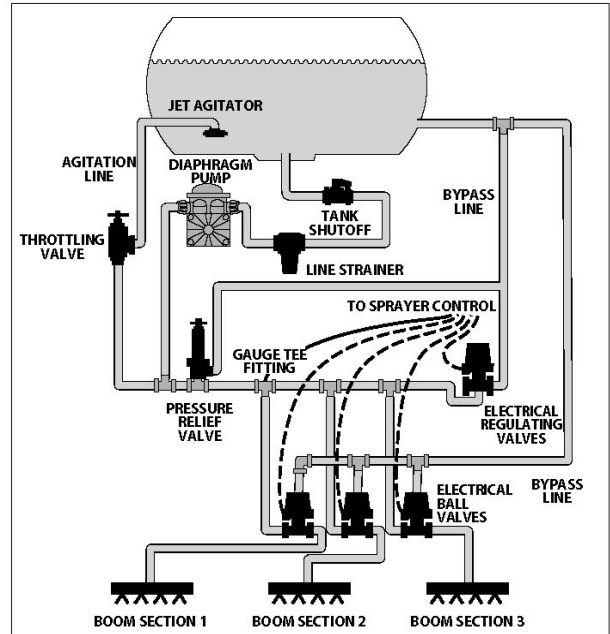

Three-Way Plumbing Diagram (Positive Displacement)

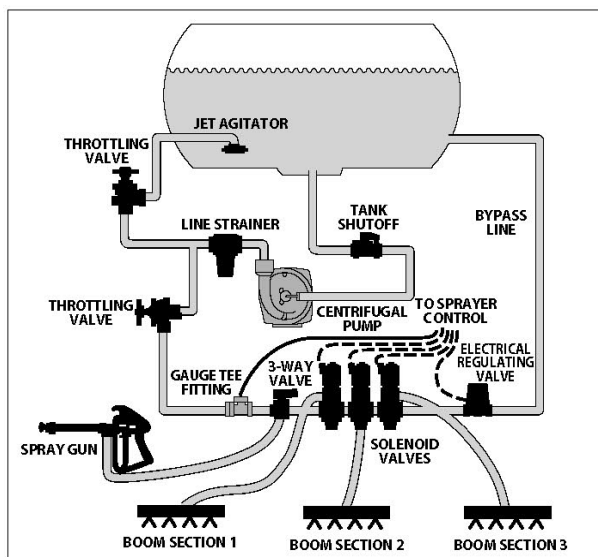

Two-Way Plumbing Diagram (Non-Positive Displacement)

Non-Positive Displacement Pump

The centrifugal pump is the most common non-positive displacement pump. The output from this type of pump is influenced by pressure. This pump is ideal for delivering large volumes of liquid at low pressures. A key component of the centrifugal pump is the throttling valve. A manual throttling valve on the main output line is essential for the accurate operation of the centrifugal pump.